



Owner's Manual and Instructions

Therma Grow™ Greenhouse Heaters



MODELS	OUTPUT (Btuh)	FUEL
HW120	120,000	Available in either L.P. Gas Vapor Withdrawal or Natural Gas Configurations.



Congratulations!

You have purchased the finest greenhouse heater available.

Your new L.B. White heater incorporates the benefits from the most experienced manufacturer of heating products using state-of-the-art technology.

We, at L.B. White, **thank you** for your confidence in our products and welcome any suggestions or comments you may have...call us, toll-free, at 1-800-345-7200.

ATTENTION ALL USERS

This heater has been tested and evaluated by C.S.A. International in accordance with IAS U.S. Requirements for Gas Fired Greenhouse Heaters and is listed and approved as a direct gas-fired circulating heater for the heating of greenhouses. If you are considering using this product for any application other than its intended use, then please contact your fuel gas supplier, or the L.B. White Co., Inc.



Quality heaters you can count on.

W6636 L.B. White Rd., Onalaska, WI 54650 ■ (800) 345-7200 ■ (608) 783-5691 ■ (608) 783-6115, fax ■ info@lbwhite.com

150-27701



GENERAL HAZARD WARNING

- Failure to comply with the precautions and instructions provided with this heater, can result in:
 - Death
 - Serious bodily injury or burns
 - Property damage or loss from fire or explosion
 - Asphyxiation due to lack of adequate air supply or carbon monoxide poisoning
 - Electrical shock
- Read this Owner's Manual before installing or using this heater.
- Only properly-trained service people should repair or install this heater.
- Save this Owner's Manual for future use and reference.
- Owner's Manuals and replacement labels are available at no charge. For assistance, contact L.B. White at 800-345-7200.



WARNING

- Proper gas supply pressure must be provided to the inlet of the heater.
- Refer to dataplate for proper gas supply pressure.
- Gas pressure in excess of the maximum inlet pressure specified at the heater inlet can cause fires or explosions.
- Fires or explosions can lead to serious injury, death, building damage, or loss of plant life.
- Gas pressure below the minimum inlet pressure specified at the heater inlet may cause improper combustion.
- Improper combustion can lead to asphyxiation or carbon monoxide poisoning and therefore serious injury or death to humans and plant life.



WARNING

Fire and Explosion Hazard

- Not for home or recreational vehicle use.
- Installation of this heater in a home or recreational vehicle may result in a fire or explosion.
- Fire or explosions can cause property damage or loss of life.

FOR YOUR SAFETY

Do not store or use gasoline or other flammable vapors and liquids in the vicinity of this or any other appliance.

FOR YOUR SAFETY

If you smell gas:

1. Open windows.
2. Don't touch electrical switches.
3. Extinguish any open flame.
4. Immediately call your gas supplier.



WARNING

Fire and Explosion Hazard

- Keep solid combustibles a safe distance away from the heater.
- Solid combustibles include wood or paper products, straw, and dust.
- Do not use the heater in spaces which contain or may contain volatile or airborne combustibles.
- Volatile or airborne combustibles include gasoline, solvents, paint thinner, dust particles or unknown chemicals.
- Failure to follow these instructions may result in a fire or explosion.
- Fire or explosions can lead to property damage, personal injury or loss of life.



Table of Contents

SECTION	PAGE
General Information	3
Heater Specifications	4
Safety Precautions	5
Installation Instructions	
General	7
Air Discharge Diverter Duct Installation Instructions	8
Indoor Ventilation Requirements	9
Air inlet	9
Exhaust Fan	10
Hanging the Heater	10
Sediment Trap Assembly Instructions	11
Thermostat Installation Instructions	11
Manual Shut-Off Valve, Hose and Regulator Assembly Instructions	11
Start-Up Instructions	12
Shut-Down Instructions	12
Cleaning Instructions	13
Maintenance Instructions	13
Service Instructions	
General	14
Motor & Fan Assembly	14
Air Proving Switch	15
Testing the Manual Reset High Limit Switch	15
Burner Orifice and Gas Control Valve	15
Gas Pressure Checks	16
Igniter and Flame Sensor	17
Troubleshooting Instructions	18
Electrical Connection and Ladder Diagram	24
Heater Component Function	25
Parts Identification (Parts List & Schematic)	26 & 27
Warranty Policy	28
Replacement Parts and Service	28

General Information

This Owner's Manual includes all options and accessories commonly used on this heater. However, depending on the configuration purchased, some options and accessories may not be included.

When calling for technical service assistance, or for other specific information, always have model number, configuration number and serial number available. This information is contained on the dataplate. The dataplate is located on the interior of either the burner end or motor end door.

This manual will instruct you in the operation and care of your unit. Have your qualified installer review this manual with you so that you fully understand the heater and how it functions.

The gas supply line installation, installation of the heater, and repair and servicing of the heater requires continuing expert training and knowledge of gas heaters and should not be attempted by anyone who is not so qualified. See page 6 for definition of the necessary qualifications. A detailed Installation and Service Guide is available, at no charge, to qualified personnel by contacting the local L.B. White distributor, dealer or the L.B. White Company.

Contact your local L.B. White distributor or the L.B. White Co., Inc. for assistance, or if you have any questions about the use of the equipment or its application.

The L.B. White Co., Inc. has a policy of continuous product improvement. It reserves the right to change specifications and design without notice.

Heater Specifications

SPECIFICATIONS		Model	
		HW120	
		Propane Gas	Natural Gas
Maximum Input (BTUH)		120,000	
Indoor Mounting Air Exchange Requirements ⁽¹⁾	EXHAUST FAN	300 CFM	
	SHUTTERED AIR INLET	120 sq. in.	
Outdoor Mounting Air Exchange Requirements ⁽¹⁾	SHUTTERED EXHAUST OUTLET	64 sq. in.	
Inlet Gas Supply Pressure Acceptable at the Inlet of the Heater for Purpose of Input Adjustment (In. W.C.)	MAX.	13.5	11.0
	MIN.	11.0	7.0
Burner Manifold Pressure (In. W.C.)		5.0	3.1
Fuel Consumption Per Hour		5.56 lbs.	120 cu. ft.
Motor Characteristics		Ball Bearing	
		1/3 H.P.	
		1,100 RPM	
Electrical Supply (Volts/Hz/Phase)		115/60/1	
Amp Draw	STARTING	11.8	
	CONTINUOUS OPERATION	4.5	
Dimensions (Inches) L x W x H		30 3/4 x 21 x 28 1/4	
Minimum Safe Distances From Nearest Combustible Materials	TOP	1 ft.	
	SIDES	1 ft.	
	BACK	1 ft.	
	BLOWER OUTLET	6 ft. (1.83 m)	
	GAS SUPPLY	Propane Gas Supply – 6 ft. (1.83 m) Natural Gas Supply – N/A	

(1) Air inlets and exhaust outlets must be electromechanically operated and electrically interlocked with the heater to prevent heater operation if air inlet and exhaust outlet do not open when heating is required.

Safety Precautions

WARNING **Asphyxiation Hazard**

- Do not use this heater for heating human living quarters.
- Do not use in areas without proper air exchange. See air exchange requirements on page 4 or on heater's dataplate.
- Exhaust fans, supply air inlets, or exhaust fan outlets must not be obstructed.
- Proper air exchange must be provided for either indoor or outdoor mount installations.
- Refer to the specification section and installation instructions of the heater's Owner's Manual, heater dataplate, or contact the L.B. White Company to determine air exchange requirements of the heater.
- Lack of proper air exchange will lead to improper combustion.
- Improper combustion can lead to carbon monoxide poisoning in humans leading to serious injury or death. Symptoms of carbon monoxide poisoning can include headaches, dizziness and difficulty in breathing.

FUEL GAS ODOR

LP gas and natural gas have man-made odorants added specifically for detection of fuel gas leaks. If a gas leak occurs, you should be able to smell the fuel gas.

THAT'S YOUR SIGNAL TO GO INTO IMMEDIATE ACTION!

- Do not take any action that could ignite the fuel gas. Do not operate any electrical switches. Do not pull any power supply or extension cords. Do not light matches or any other source of flame. Do not use your telephone.
- Get everyone out of the building and away from the area immediately.
- Close all propane gas tank or cylinder fuel supply valves, or the main fuel supply valve located at the meter if you use natural gas.
- Propane gas is heavier than air and may settle in low areas. When you have reason to suspect a propane leak, keep out of all low areas.
- Natural gas is lighter than air and can collect around rafters or ceilings.
- Use your neighbor's phone and call your fuel gas supplier and your fire department. Do not re-enter the building or area.
- Stay out of the building and away from the area until declared safe by the firefighters and your fuel gas supplier.
- **FINALLY**, let the fuel gas service person and the firefighters check for escaped gas. Have them air out the building and area before you return. Properly trained service people must repair the leak, check for further leakages, and then relight the appliance for you.

ODOR FADING -- NO ODOR DETECTED

- **Some people cannot smell well. Some people cannot smell the odor of the man-made chemical added to propane (LP) or natural gas. You must determine if you can smell the odorant in these fuel gases.**
- Learn to recognize the odor of propane gas and natural gas. Local propane gas dealers and your local natural gas supplier (utility) will be more than happy to give you a scratch and sniff pamphlet. Use it to become familiar with the fuel gas odor.
- Smoking can decrease your ability to smell. Being around an odor for a period of time can affect your sensitivity to that particular odor.
- **The odorant in propane gas and natural gas is colorless and the intensity of its odor can fade under some circumstances.**
- If there is an underground leak, the movement of gas through the soil can filter the odorant.
- Propane gas odor may differ in intensity at different levels. Since propane gas is heavier than air, there may be more odor at lower levels.
- **Always be sensitive to the slightest gas odor.** If you continue to detect any gas odor, no matter how small, treat it as a serious leak. Immediately go into action as discussed previously.

ATTENTION -- CRITICAL POINTS TO REMEMBER!

- Propane gas and natural gas have a distinctive odor. Learn to recognize these odors. (Reference Fuel Gas Odor and Odor Fading sections above.)
- If you have not been properly trained in repair and service of propane gas and natural gas fueled heaters, then do not attempt to light heater, perform service or repairs, or make any adjustments to the heater on propane gas or natural gas fuel system.
- Even if you are not properly trained in the service and repair of the heater, ALWAYS be consciously aware of the odors of propane gas and natural gas.
- A periodic sniff test around the heater or at the heater's joints; i.e. hose, connections, etc., is a good safety practice under any conditions. If you smell even a small amount of gas, CONTACT YOUR FUEL GAS SUPPLIER IMMEDIATELY. DO NOT WAIT!

1. Do not attempt to install, repair, or service this heater or the gas supply line unless you have continuing expert training and knowledge of gas heaters.

Qualifications for service and installation of this equipment are as follows:

- a. To be a qualified gas heater service person, you must have sufficient training and experience to handle all aspects of gas-fired heater installation, service and repair. This includes the task of installation, troubleshooting, replacement of defective parts and testing of the heater. You must be able to place the heater into a continuing safe and normal operating condition. You must completely familiarize yourself with each model heater by reading and complying with the safety instructions, labels, Owner's Manual, etc., that is provided with each heater.
 - b. To be a qualified gas installation person, you must have sufficient training and experience to handle all aspects of installing, repairing and altering gas lines, including selecting and installing the proper equipment, and selecting proper pipe and tank size to be used. This must be done in accordance with all local, state and national codes as well as the manufacturer's requirements.
2. All installations and applications of L.B. White heaters must meet all relevant local, state and national codes. Included are L.P. gas, natural gas, electrical, and safety codes. Your local fuel gas supplier, a local licensed electrician, the local fire department or similar government agencies, or your insurance agent can help you determine code requirements. Refer to the following:
 - ANSI/NFPA 58, latest edition, Standard for Storage and Handling of Liquefied Petroleum Gas and/or
 - ANSI Z223.1/NFPA 54, National Fuel Gas Code
 - ANSI/NFPA 70, National Electrical Code.
 3. Do not move, handle, or service heater while in operation or connected to a power or fuel supply.
 4. This heater may be installed in areas subject to washdown. This heater may only be washed on the external case assembly—see Cleaning Instructions. Do not wash the interior of the heater. Use only compressed air, soft brush or dry cloth to clean the interior of the heater and its components. After external washdown, do not operate this heater until it is completely dry. In any event, do not operate the heater for at least one hour after external washdown.
 5. For safety, this heater is equipped with a manual reset high-limit switch and an air proving switch. Never operate this heater with any safety device that has been bypassed. Do not operate this heater unless all of these features are fully functioning.

6. Do not operate the heater with its door open.
7. Do not locate fuel gas containers or fuel supply hoses anywhere near the blower outlet of the heater.
8. Do not block air intakes or discharge outlets of the appliance. Doing so may cause improper combustion or damage to heater components leading to property damage or plant loss.
9. The hose assembly shall be visually inspected on an annual basis. If it is evident there is excessive abrasion or wear, or if the hose is cut, it must be replaced prior to the heater being put into operation. The hose assembly shall be protected from animals, building materials, and contact with hot surfaces during use. The hose assembly shall be that specified by the manufacturer. See parts list.
10. Check for gas leaks and proper function upon heater installation, before building repopulation or when relocating.
11. This heater should be inspected for proper operation by a qualified service person before building repopulation and at least annually.
12. Always turn off the gas supply to the heater if the heater is not going to be used.
13. This heater is equipped with a three-prong (grounding) plug for your protection against shock hazard and must be plugged directly into a properly grounded three-prong receptacle. Failure to use a properly grounded receptacle can result in electrical shock, personal injury, or death.
14. Direct ignition heaters will make up to three trials for ignition. If ignition is not achieved, the control system will lock out the gas control valve. If gas is smelled after system lock out has occurred, immediately close all fuel supply valves. Do not relight until you are sure that all gas that may have accumulated has cleared away. In any event, do not relight for at least 5 minutes.
15. In a hanging type installation, rigid pipe or copper tubing coupled directly to the heater may cause gas leaks during movement, and therefore must not be used. Use only gas hose assemblies that are rated and approved for L.P. gas and natural gas in a hanging type of installation.
16. Installations not using the gas hose supplied with this appliance must connect dimensionally using American National Standard Wrought Steel and Wrought Iron Pipe B36/10-1970. (Aluminum piping or tubing shall not be used.) Copper tubing when used for conveying natural gas, shall be internally tinned or equivalently treated to resist sulphur.

Installation Instructions

GENERAL

Direct fired heaters discharge combustion by-products with the heated air in to the area being heated. These include CO, CO₂, NO, NO₂, and Ethylene. These gases can result in harm to the worker or the plants.

This greenhouse heater has been specifically developed for very low levels of these combustion by-products. However, it is necessary to have an exchange of air within the greenhouse to avoid accumulation of these gases to a harmful level over an extended period of operating time.

Greenhouses have a natural air leakage factor. This natural leakage is influenced by the design and physical condition of the greenhouse as well as wind conditions and other factors. This natural leakage factor can not be relied upon as being sufficient to provide the necessary air exchange within the greenhouse. Proper installation of the GreenGro greenhouse heater must include provision for adequate air exchange as follows:

Indoor Mounted Heater:

- An exhaust fan capable of providing at least 300 cfm of discharge air.
- An inlet shuttered louver of at least 120 sq. in. area.
- The inlet shutters must be electromechanically operated and electrically interlocked with the heater such that the heater can not operate if the inlet shutters do not open when heating is required.
- Refer to Indoor Ventilation Requirements in this manual.

Outdoor Mounted Heater:

- An exhaust shuttered louver of at least 64 sq. in. area.
 - The exhaust shutter must be electromechanically operated and electrically interlocked with the heater such that the heater can not operate if the exhaust shutters do not open when heating is required.
1. Read all safety precautions and follow L. B. White recommendations when installing this heater. If during the installation or relocating of heater, you suspect that a part is damaged or defective, call a qualified service agency for repair or replacement.
 2. Make sure the heater is properly positioned before use and is hung level. Observe and obey all minimum safe distances of the heater to the nearest combustible materials. Minimum safe distances are given on the heater nameplate and on page 4 of this manual.
 3. The heater may be used either indoors or outdoors. For heaters intended for outdoor installation, the heater is to be installed at least 18 inches above the ground or to a height that would prevent snow blockage of heater's air inlet. Refer to instructions provided in the optional L.B. White outdoor mounting and ducting kit, part number 23578.
 4. The heater must have the proper gas regulator installed for the application. A regulator must be connected to the gas supply so that gas pressure at the inlet to the gas valve is regulated within the range specified on the dataplate at all times. Contact your gas supplier, or the L.B. White Co., Inc. if you have any questions.

5. The heater's gas regulator (with pressure relief valve) should be installed outside of building. Any regulators inside the buildings must be properly vented to the outside. Local, state and national codes always apply to regulator installation. Natural gas regulators with vent limiting device may be mounted indoors without venting to outdoors.
6. All gas pressure regulators must be installed in strict accordance with the manufacturer's safety instructions. These instructions accompany each regulator.
7. Insure that all accessories that ship within the heater have been removed from inside of heater and installed. This pertains to air diverters, hose, regulators, etc.
8. Make certain that a sediment trap is installed at the gas valve inlet to prevent foreign materials (pipe compound, pipe chips and scale) from entering the gas valve. Debris blown into the gas valve may cause that valve to malfunction resulting in a serious gas leak that could result in a possible fire or explosion causing loss of products, building, or even life. A properly installed sediment trap will keep foreign materials from entering the gas valve and protect the safe functioning of that important safety component.
9. Any heater connected to a piping system must have an accessible, approved manual shut off valve installed within six feet (6 ft.) of the heater it serves.
10. Check all connections for gas leaks using approved gas leak detectors. Gas leak testing is performed as follows:



WARNING **Fire and Explosion Hazard**

- Do not use open flame (matches, torches, candles, etc.) in checking for gas leaks.
- Use only approved leak detectors.
- Failure to follow this warning can lead to fires or explosions.
- Fires or explosions can lead to property damage, personal injury or loss of life.

- Check all pipe connections, hose connections, fittings and adapters upstream of the gas control with approved gas leak detectors.
- In the event a gas leak is detected, check the components involved for cleanliness and proper application of pipe compound before further tightening.
- Furthermore tighten the gas connections as necessary to stop the leak.
- After all connections are checked and any leaks are stopped, turn on the main burner.
- Stand clear while the main burner ignites to prevent injury caused from hidden leaks that could cause flashback.
- With the main burner in operation, check all connections, hose connections, fittings and joints as well as the gas control valve inlet and outlet connections with approved gas leak detectors.

- If a leak is detected, check the components involved for cleanliness in the thread areas and proper application of pipe compound before further tightening.
 - With the main burner in operation, check all connections, hose connections, fittings and joints as well as the gas control valve inlet and outlet connections with approved gas leak detectors.
 - If a leak is detected, check the components involved for cleanliness in the thread areas and proper application of pipe compound before further tightening.
 - Tighten the gas connection as necessary to stop the leak.
 - If necessary, replace the parts or components involved if the leak cannot be stopped.
 - Ensure all gas leaks have been identified and repaired before proceeding.
11. A qualified service agency must check for proper operating gas pressure upon installation of the heater.
 12. Light according to instructions on heater or within owner's manual.
 13. It is extremely important to use the proper size and type of gas supply line to assure proper functioning of the heater. Contact your fuel gas supplier for proper line sizing and installation.
 14. This heater can be configured for use with either L.P. gas vapor withdrawal or natural gas. Consult the dataplate for the gas configuration of the specific heater. Do not use the heater in an L.P. gas liquid withdrawal system or application. If you are in doubt, contact the L.B. White Co., Inc.
 15. Eventually, like all electrical/mechanical devices, the thermostat can fail. Thermostat failure may result in either an underheating or overheating condition which may damage or kill plants. Plants should be protected by a separate back-up control system that limits high and low temperatures and also activates appropriate alarms.
 16. Take time to understand how to operate and maintain the heater by using this Owner's Manual. Make sure you know how to shut off the gas supply to the building and also to the individual heater. Contact your fuel gas supplier if you have any questions.
 17. Any defects found in performing any of the service or maintenance procedures must be eliminated and defective parts replaced immediately. The heater must be retested by properly qualified service personnel before placing the heater back into use.
 18. Do not exceed input rating stamped on the dataplate of the heater. Do not exceed the burner manifold pressure stated on the dataplate. Do not use an orifice size different than specified for the specific input rating of this heater, fuel type configuration and altitude.

AIR DISCHARGE DIVERTER DUCT

Part Number 26113 (Accessory)

1. The air discharge diverter duct provides improved directional air flow and greater heat throw, beneficial in heating long houses. Use the duct **only** on indoor mounted heaters. Do not use the diverter when the heater is mounted outside the greenhouse. The diverter duct requires hand forming prior to assembly. Make 90 degree bends utilizing the perforations provided. Assemble as shown in Fig. 1.

FIG. 1

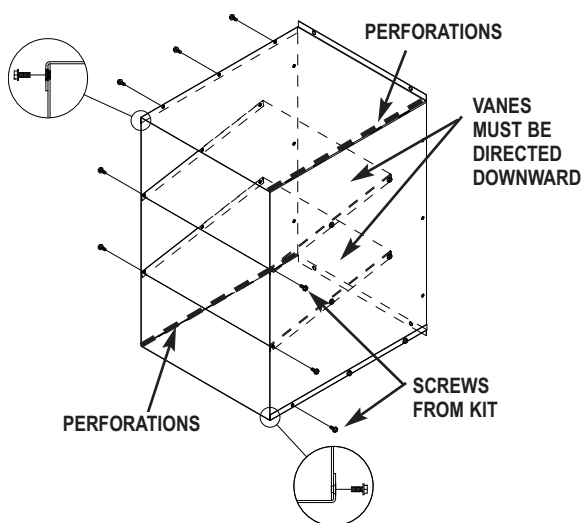

2. Remove the screws at both sides of the blower outlet.
3. Install flanges as shown in Fig. 2, using the same screws. Tighten the screws securely.
4. Position the diverter assembly over the flanges. Align holes in diverter to flange holes.
5. Fasten the diverter to the flanges with the screws provided. See Fig. 3.

FIG. 2



FIG. 3



INDOOR VENTILATION REQUIREMENTS

This heater requires a properly sized, motorized air inlet shutter and exhaust fan for indoor installation. These components, along with specific instructions, are provided in indoor ventilation kit # 25995.

Air Inlet

Locate the air inlet directly beneath the heater and align it to the heater's air inlet for combustion air supply. Ensure the motorized air inlet and the heater's air inlet are kept free of any blockages.

- The air inlet must be located directly beneath the heater's air inlet, and have access to outside fresh air. See Fig. 4a.
- The heater draws its combustion air through holes in its base. The motorized air inlet must be centered to the heater's air inlet. See Fig. 4b.
- The motorized air inlet must be no more than 1 1/2 ft. from the back of the heater and properly aligned to the heater. See Fig. 4c.
- The heater should have a minimum clearance of 1 1/2 ft. above the ground. See Fig. 4c.

FIG. 4a
Blower Outlet View

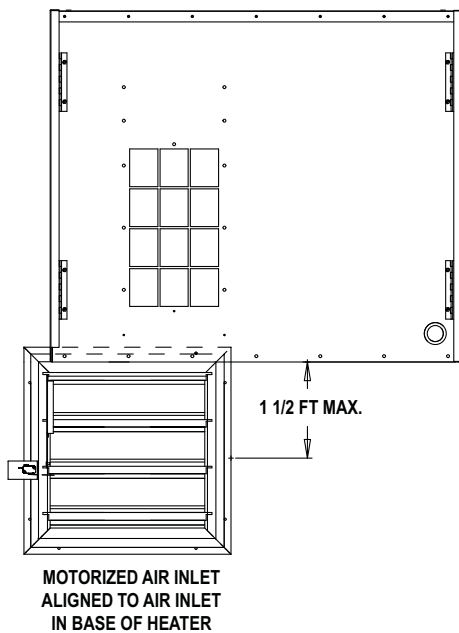

FIG. 4b
Underside View

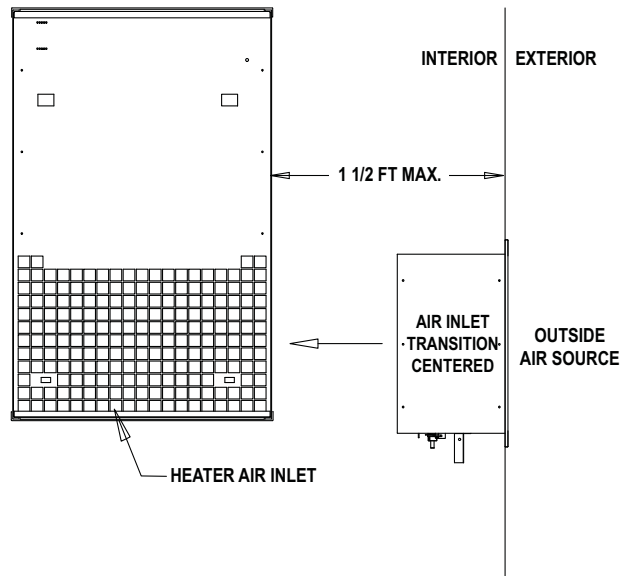
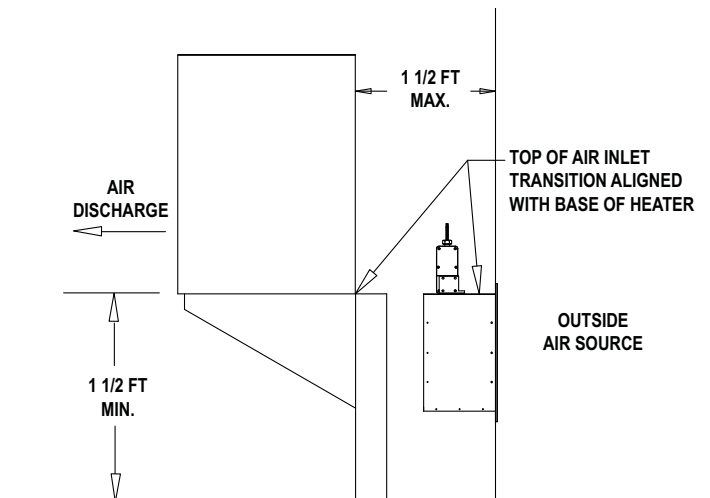

FIG. 4c
Side View



Exhaust Fan

The exhaust fan **must** be located at an upper area of the end wall opposite from the heater, preferably in an area higher than the heater's discharge. See Fig. 5. The fan does not need to be directly in line to the heater. Ensure the exhaust fan is kept free of blockage.

FIG. 5

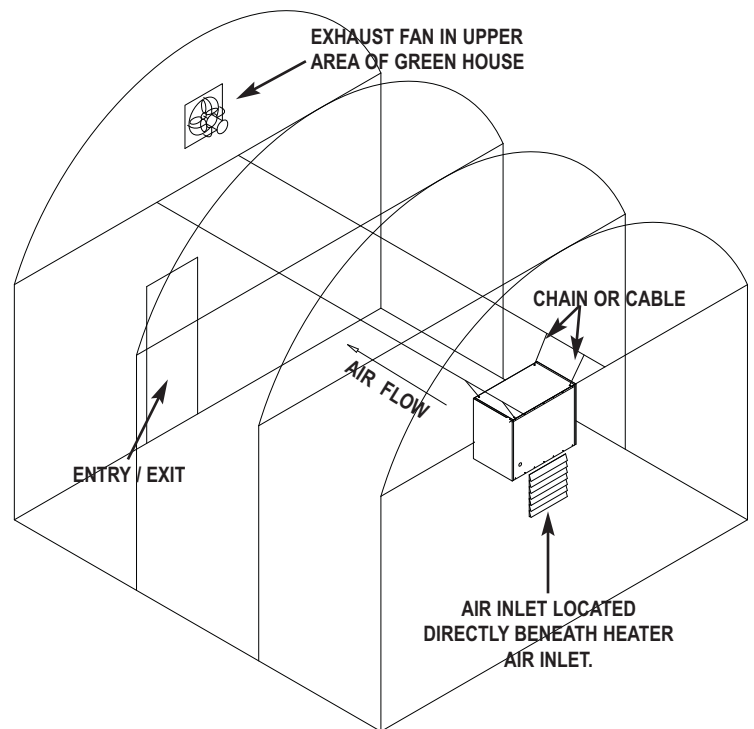

HANGING THE HEATER

This heater may be mounted within the greenhouse for indoor heating applications. The heater may be installed on an optional indoor mounting bracket kit, part number 23651, which is installed on freestanding supports or mounted directly to the structure's wall. Separate installation instructions accompany the kit.

The heater may also be suspended by chain to the greenhouse's overhead structure by using an optional chain hanging kit, part number 07802. Refer to the following instructions and illustrations.

1. Assemble eyebolts and chain according to the illustration and tighten all eyebolts securely.

FIG. 6

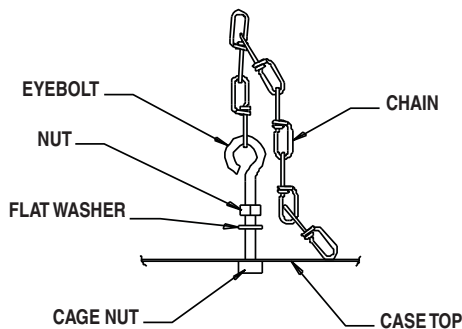

2. Ensure the heater is securely fastened to overhead supports and is hanging level. (Check crosswise and lengthwise.)
3. See Fig. 5 for **typical** indoor installation. In any installation, consideration must be given to making sure the heater is located away from the people entering or exiting the greenhouse so they cannot accidentally knock the heater or tamper with the heater and its gas supply line. Additionally, the heater must be located so that it does not block the normal entryway or exit of the building. Observe and obey minimum clearance distances to combustible materials as stated in the specification section of this owner's manual and on the heater's dataplate.

SEDIMENT TRAP ASSEMBLY

Assemble the tee, nipples and cap together and tighten securely. See Fig. 7. The sediment trap assembly must always be mounted in a vertical position. Make sure pipe thread compound that is resistant to both L.P. gas and natural gas is used in making all connections. **Check all connections for gas leaks using approved gas leak detectors.**

FIG. 7

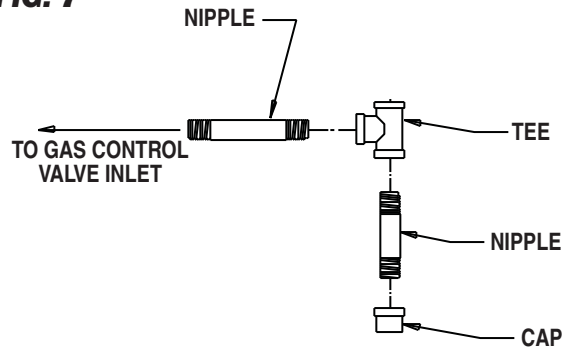

THERMOSTAT INSTALLATION



WARNING Electrical Shock Hazard

- Disconnect the electrical supply before connecting the thermostat to the heater.
- Failure to follow this warning can result in electrical shock, leading to personal injury or death.

1. To Connect the Series Tap Plug Thermostat Kit:

- a. Connect the power cord of the heater to the female side of the plug on the end of the thermostat cord.
- b. Plug the male side of the series tap plug on the thermostat cord into a three-wire (grounded) electrical outlet within the building.

2. To Connect the Direct Wired Thermostat Kit to the Control Box on the Heater:

- a. The installation and wiring of a thermostat must be done by an electrician or someone properly qualified.
- b. The thermostat may use 18 gauge, 2 wire cord to handle the low voltage being supplied to the thermostat from the transformer.
- c. Follow all instructions provided with the thermostat kit.
- d. The heater must be tested for proper operation after the thermostat has been connected.

MANUAL SHUT-OFF VALVE, HOSE AND REGULATOR ASSEMBLY

1. Always use approved pipe thread compound suitable for use with L.P. gas or natural gas on the threaded connections.
2. Assemble the components together according to the figure. This view is to show general assembly of the components only. The regulator must always be mounted so its vent, regardless of location on the regulator, is always pointed downward.
3. Tighten all connections securely and check for gas leaks.

FIG. 8

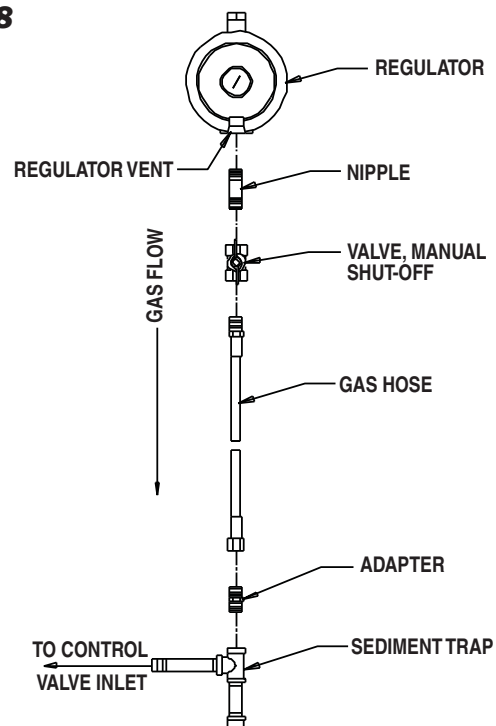

Start-Up Instructions

Follow steps 1 - 6 on initial start-up after heater installation by a qualified gas heater service person. For normal start-up, simply turn thermostat above room temperature. The heater will start.

1. Open all manual fuel supply valves and check for gas leaks using approved leak detectors. The gas control valve on the heater has a manual shut-off feature incorporated into the valve assembly. Make sure the indicator on the valve is turned to the "on" position. See Fig. 9.

FIG. 9

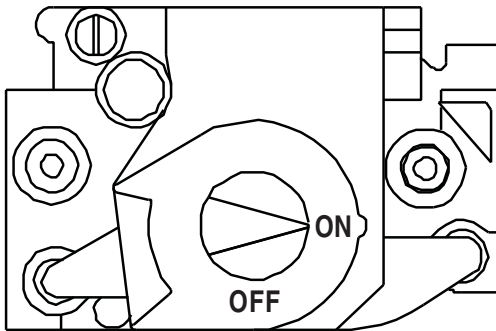

2. Connect the electrical cord to an approved electrical outlet.
3. Set the thermostat (if supplied) to desired room temperature.
4. This heater includes a hot surface ignition (HSI) control module for purposes of controlling the timing of the ignition process of the heater as well as monitoring of the safety functions. The HSI module is contained within the control enclosure.

When the selector switch is positioned to heat, the red light emitting diode (LED) on the ignition control will be on. This LED indicates the status of the heater. The LED is visible through the plastic window of the control box. A constant light from the LED is an indicator that the heater is functioning correctly. Any flash pattern by the LED indicates there is a problem in the operation of the heater. Refer to the

troubleshooting decal adjacent to the control box for assistance in troubleshooting. Only qualified and properly trained personnel shall service or repair the heater.

On a call for heat, the motor will start and run for five (5) seconds and then stop. This pre-purge is a safety feature and a normal operational characteristic prior to ignition taking place. After the motor has stopped, the igniter will heat up (approximately 17 seconds). After igniter warm up time has been achieved, the motor will start again and shortly thereafter ignition will occur.

NOTE: It is normal for air to be trapped in the gas hose on new installations. The heater may attempt more than one trial for ignition before the air is finally purged from the line and ignition takes place.

4. The HSI control will make up to three trials for ignition. Each trial for ignition will take approximately 20 seconds. The first two trials for ignition will occur within 40 seconds if ignition is not achieved. A 15 minute wait period will then begin after the second trial for ignition has taken place. After the 15 minute time has passed, the third and final trial for ignition will take place. If ignition is not achieved at this final trial, the system will lock out, and a three flash pattern will be indicated by the LED.
6. Do not exceed input rating stamped on nameplate or manufacturer's recommended burner orifice pressure for size orifice(s) used. Make certain that the primary air supply to main burner is open and free of dust, dirt and debris for complete, proper combustion.

Shut-Down Instructions

If the heater is to be shut down for cleaning, maintenance or repair, follow steps 1 - 5. Otherwise, simply turn thermostat to off or no heat for standard shut down.

1. Close all manual fuel supply valves.
2. With the heater lit, allow heater to burn off excess fuel in gas supply hose.
3. Turn the indicator on the gas control to off.
4. Turn thermostat to off or no heat position.
5. Disconnect the heater from the electrical supply.

Cleaning Instructions



WARNING

Fire, Burn, and Explosion Hazard

- This heater contains electrical and mechanical components in the gas management, and safety systems.
- Such components may become inoperative or fail due to dust, dirt, wear and aging.
- Periodic cleaning and inspection as well as proper maintenance are essential to avoid serious injury or property damage.

1. Before cleaning, shut off all gas supply valves and disconnect electrical supply.
2. At least once a year give the heater a thorough cleaning, preferably before the beginning of the fall heating season. At that time, remove the fan and motor assembly and brush or blow off the fan wheel. Additionally, ensure the burner casting and orifice are free of dust accumulation, insect nests, webs, etc.



WARNING

Do not use a pressure washer, water, or liquid cleaning solution on any heater components. Use of a pressure washer, water, or liquid cleaning solution on the control components can cause severe personal injury or property damage due to water and/or liquids:

- In electrical components, and wires causing electrical shock or equipment failure.
- On gas control valves causing corrosion which can result in gas leaks and fire or explosion from the leak.

Clean all internal components of the heater with pressurized air, a dry brush, or a dry cloth.

Maintenance Instructions

1. The area surrounding the heater shall be kept clear and free from combustible materials, gasoline, and other flammable vapors and liquids.
2. Have your gas supplier check all gas piping annually for leaks or restrictions in gas lines.
3. Regulators must be periodically inspected to make sure the regulator vents are not blocked. Debris, insects, insect nests, snow, or ice on a regulator can block vents and cause excess pressure at the heater.
4. Regulators can wear out and function improperly. Have your gas supplier check the date codes on all regulators installed and check delivery pressures to the heater to make sure that the regulator is reliable.
5. Check all wiring associated terminals and electrical components within the heater for corrosion, frayed or cut insulation, tight connections, etc. Repair or replace as necessary.
6. Review all heater markings (i.e. wiring diagram, warnings, start-up, shut-down, troubleshooting, etc.) at the time of maintenance for legibility. Make sure none are cut, torn, or otherwise damaged. Any damaged markings must be replaced immediately by contacting the L.B. White Co., Inc. Dataplates, start-up and shut-down instructions and warnings are available at no cost. A nominal charge will be applied for wiring diagrams.

Service Instructions

GENERAL

WARNING **Burn Hazard**

- Heater surfaces are hot for a period of time after the heater has been shut down.
- Allow the heater to cool before performing service, maintenance, or cleaning.
- Failure to follow this warning will result in burns causing injury.

WARNING **Fire and Explosion Hazard**

- Do not disassemble or attempt to repair any component part of the heater, including regulators and gas hoses.
- All components must be replaced if defects are found.
- Failure to follow this warning will result in gas leaks.
- Gas leaks cause fire or explosions, leading to property damage, injury, or death.

1. Close the fuel supply valve to the heater and disconnect the electrical supply before servicing unless necessary for your service procedure.
2. Open end panels for access to heater components.
3. Disconnect the appropriate electrical leads for the component being replaced.

4. The thermostat, and high limit switch can be tested by jumpering the suspect part out of the electrical circuit.:
 - Reconnect the electrical supply and open fuel supply valves.
 - If the heater lights, the component is defective and must be replaced.
 - Do not operate the heater with the component jumpered. Replace the part immediately.
 - An alternate method for checking the components is to perform a continuity check.
5. Do not jumper the air proving switch. If jumpered, the ignition control will not allow heater operation. Test the air proving switch for continuity. If defective, replace the switch
6. For reassembly, reverse the respective service procedure. Ensure gas connections are tightened securely.
7. After servicing, start the heater to ensure proper operation. Check for gas leaks with approved leak detectors.
8. Clean the heater's orifice with compressed air or a soft, dry rag. Do not use files, drills, broaches, etc. to clean the orifice. Doing so may enlarge the hole, causing combustion or ignition problems. Replace the orifice if it cannot be cleaned properly.

MOTOR AND FAN WHEEL ASSEMBLY

1. Remove the motor mounting plate screws and pull the fan and motor assembly from the housing.
2. Loosen the square head set screw(s) on the fan wheel.
3. Pull the fan wheel from the motor shaft. Use a wheel puller if necessary.
4. Remove the four (4) nuts securing the motor to the mounting plate.

NOTES: a. Fan wheel to motor mount plate spacing must be adjusted to the clearance specified in the table below before tightening the fan wheel to the motor shaft.

b. Make sure that set screw(s) of the fan are on the flats of motor shaft when tightening.

FIG. 10

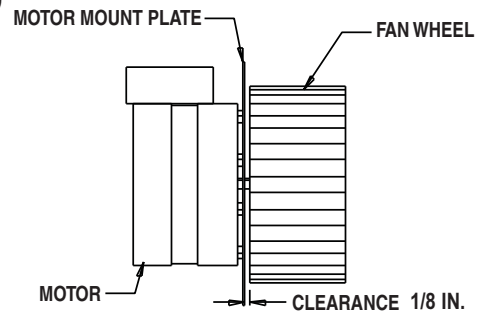

1. Remove two sheet metal screws holding air proving switch blower housing. Remove assembly by turning switch assembly 90 degrees so the switch paddle can be pulled through oblong hole on side of fan housing. See Fig. 11.
3. Disconnect the leads from the air proving switch.
4. When installing replacement switch, use care in not bending the switch arm, otherwise ignition problems may occur.

FIG. 11

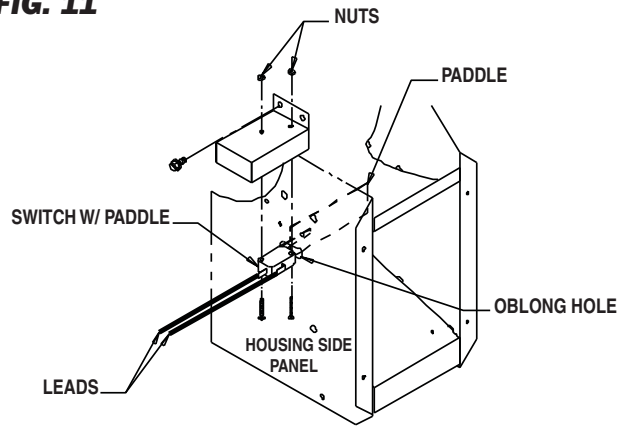

TESTING THE MANUAL RESET HIGH LIMIT SWITCH



WARNING

Fire Hazard

- Do not operate the heater with the high limit switch bypassed.
- Operating the heater with a bypassed high limit switch may lead to overheating, possibly resulting in a fire, with subsequent damage to the heater, building damage, or loss of livestock.

The high limit switch should be tested a minimum of once per year when the heater is given a thorough cleaning.

1. Remove the high limit switch from the heat chamber.
2. Holding the switch by one of its mounting legs or electrical terminals, apply a small flame only to the sensing surface on the back of the switch. **Be careful not to melt the plastic housing of the switch when conducting this test.**

3. Within a minute, you should hear a pop coming from the switch, which indicates the contacts of the switch have opened.
4. Allow the switch cool down for about a minute before firmly pressing the red reset button on the switch.
5. Check for electrical continuity across the switch terminals to make sure the contacts have closed.
6. Reinstall the switch back into the heater.

FIG. 12

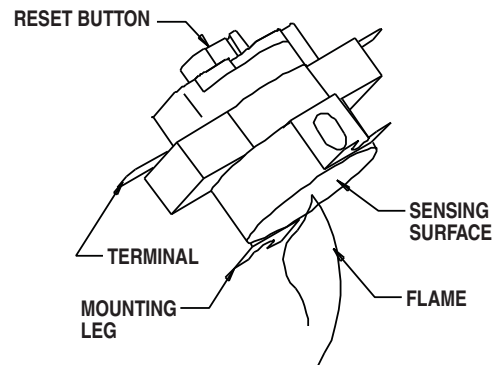

BURNER ORIFICE and GAS CONTROL VALVE

1. Remove hose and sediment trap from inlet of gas control valve.
2. Remove the following
 - Screws from bracket at inlet of gas control
 - Burner bolt from underside of base
 - Screws and spacers at burner.
3. Remove control valve with burner from heater. Pivot the valve/manifold assembly as necessary so orifice block on manifold clears the burner casting venturi port. See Fig. 13.
4. Replace component as needed.

FIG. 13

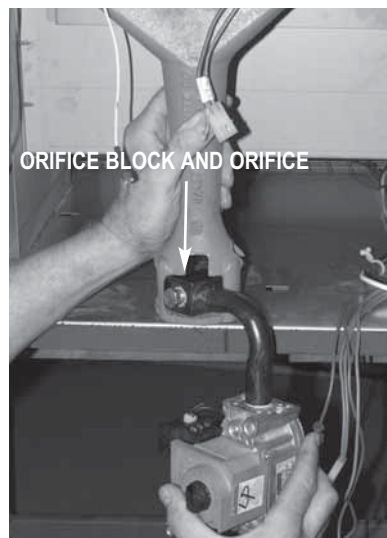

Gas Pressure Checks

WARNING

- Do not disassemble the gas control valve.
- Do not attempt to replace any components of the gas control valve.
- The gas control valve must be replaced if any physical damage occurs to the control valve assembly.
- Failure to follow this warning will result in fire or explosions, leading to injury or death to humans, and property damage.

ATTENTION

- The following explains a typical procedure to be followed in checking gas pressures.
- The gas pressures will vary depending upon fuel type.
- Consult the dataplate on the heater or page 4 in this manual for specific pressures to be used in conjunction with this procedure.
- Gas pressure measured at the inlet to the gas valve is Inlet Pressure and gas pressure measured at the outlet of the gas valve is Burner Manifold Pressure.

A. Preparation

1. Obtain two pressure gauges capable of reading up to 35 in. W.C.
2. Disconnect the heater from the electrical supply and close the fuel supply valve to the heater inlet.
3. Open the burner access panel.
4. Brush or blow off any dust and dirt on or in the vicinity of the gas control valve.

B. Gauge Installation

1. Locate the inlet and outlet pressure taps, see Fig. 14. Remove the pressure tap plug using a 3/16 in. allen key.

FIG. 14

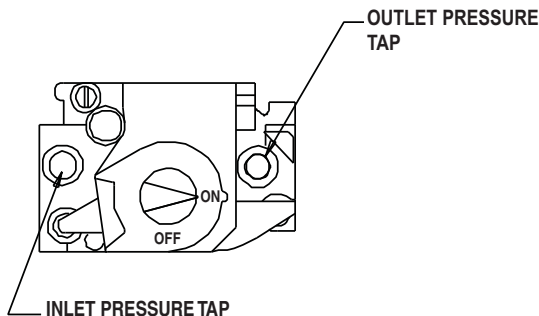

2. Securely connect a pressure gauge to each pressure tap.
3. Open the fuel supply valves to the heater and reconnect the heater electrical supply.
4. Start the heater

C. Reading Pressures

1. With the heater operating, the pressure gauges should read the pressures specified on the dataplate .
2. Do the readings at the inlet and outlet pressure gauges agree with that specified on the dataplate? If so, then no further checking or adjustment is required. Proceed to section D.
3. If the inlet pressures do not agree with that specified on the dataplate, then the regulator controlling gas pressure to the heater requires adjustment.
4. If the inlet pressures are correct and the burner manifold pressure does not agree with that specified on the dataplate, then the gas control valve's internal pressure regulator requires adjustment. See Fig. 15 for regulator location.

FIG. 15

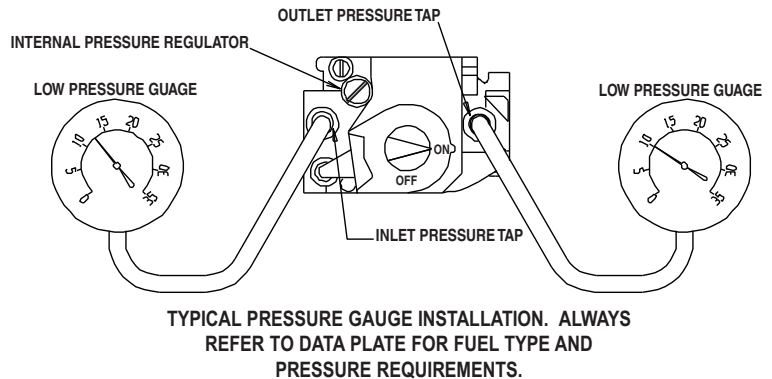

D. Completion

1. Once the proper inlet and burner manifold pressures have been confirmed and/or properly set, close the fuel supply valve to the heater and allow the heater to burn off any gas remaining in the gas supply line.
2. Disconnect the heater from its electrical supply.
3. Remove the gauges and connecting hoses.
4. Install pressure tap plugs and tighten securely. Check for gas leaks.

1. Disconnect the plastic male and female plugs located at the end of the igniter leads. See Fig. 16
 2. Loosen the screw securing the igniter shield and the igniter to the mounting bracket. Remove the igniter and shield.
 3. Ensure the igniter is located so the its lip on back side of igniter is resting on the edge of the mounting bracket and the mounting hole in the igniter aligns with the mounting hole in the bracket.
 4. Slide the igniter shield over the igniter so hole in shield aligns with hole in igniter and bracket.
- Handle the igniter by its ceramic base, or by its leads.
 - Center the igniter shield over the igniter element, making sure the shield does not touch the igniter element, otherwise igniter damage will occur when the igniter is energized..
 - Do not overtighten the igniter mounting screw. Overtightening may crack the base of the igniter, leading to premature failure.

F LAME SENSOR

Complete this procedure at least once during the heating season .

1. Remove the sensor from its mounting bracket. Clean the sensor's rod with emery cloth or steel wool to buildup of dirt to help maintain proper flame sense. See Fig. 16.
 2. Check the flame sensor's insulative base for any cracks. If cracks are found, replace the sensor.
- For proper flame sense operation, the flame sensor tip must be properly positioned within the burner flame. See Fig. 17.

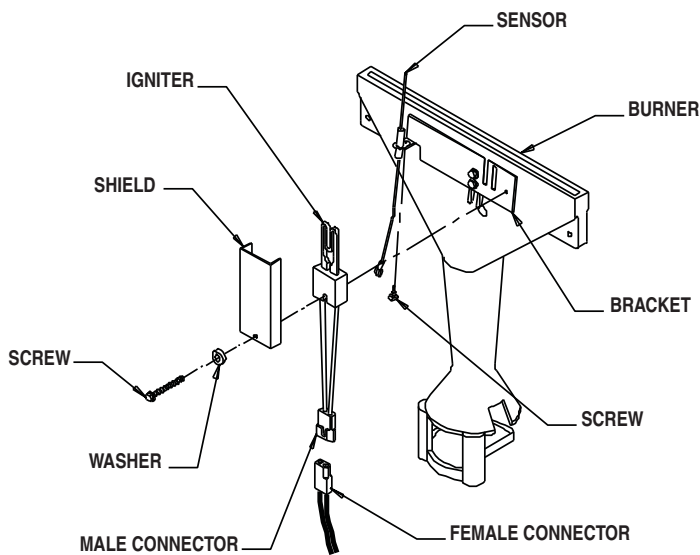
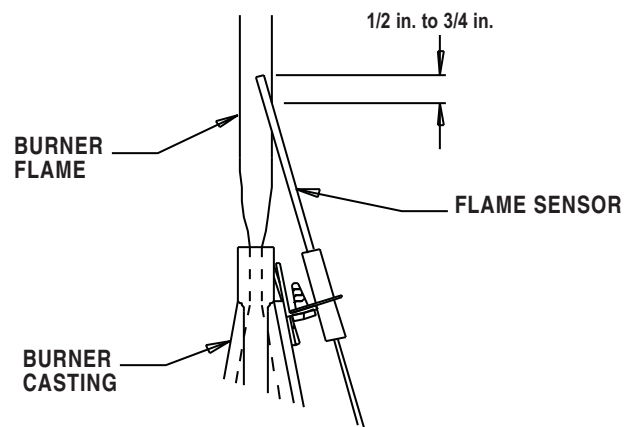
FIG. 16**FIG. 17**

Troubleshooting Instructions

READ THIS ENTIRE SECTION BEFORE BEGINNING TO TROUBLESHOOT PROBLEMS.



WARNING

- This heater can start at any time.
- Troubleshooting this system may require operating the unit with line voltage present and gas on. Use extreme caution when working on the heater.
- Failure to follow this warning may result in personal injury or death.

The following troubleshooting guide provides systematic procedures for isolating equipment problems. This guide is intended for use by a QUALIFIED GAS HEATER SERVICE PERSON. **DO NOT ATTEMPT TO SERVICE THESE HEATERS UNLESS YOU HAVE BEEN PROPERLY TRAINED.**

TEST EQUIPMENT REQUIRED

The following pieces of test equipment will be required to troubleshoot this system with minimal time and effort.

- **Digital Multimeter** - for measuring voltage and resistance.
- **Low Pressure Gauge** - for checking inlet and outlet pressures at the gas control valve against dataplate rating.

INITIAL PREPARATION

- Visually inspect equipment for apparent damage.
- Check all wiring for loose connections and worn insulation.

The ignition control module is self-diagnostic. The red light located on the control will flash a specific pattern depending upon the problem which is diagnosed. To use the flow charts, identify the problem by the light pattern of the L.E.D. (light emitting code) diagnostic light. If the light is flashing, the flash pattern will be followed by a pause and then a repeat of the flash pattern until the problem is corrected. The light will only be on when the selector switch is positioned to HEAT and the thermostat or controller is calling for heat. The light will not be on when the selector switch is positioned to VENT.

Heating Mode Problems

Page

L.E.D. light is not on during a call for heat	19
L.E.D. diagnostic light is flashing:	
A. Rapid flash	20
B. Long flash (2 seconds on-2 seconds off) . . .	20
C. One time	20
D. Two times	21
E. Three times	22
F. Four times	23
G. Five times	23
H. Six times	23

OPERATION SEQUENCE:

- Line voltage is sent to transformer
 - Terminal at transformer branches off line voltage to . . . terminal L1 on ignition control.
- Transformer reduces line voltage to 24 VAC.
- 24 VAC is sent to thermostat.
- Thermostat closes and returns 24 volts to terminal W on ignition control.
- Red light on ignition control is illuminated.
- Ignition control sends flame sense current to flame sensor.
- Ignition control module performs self safety check.
 - Internal components are tested.
 - Air proving circuit is tested
 - Control sends 24 VAC from terminal PSI to air . . . proving switch.
- Ignition control module begins ignition trial sequence.
- Ignition control sends 115 volts from terminal IND to motor.
 - Motor starts.
- Air proving switch closes and 24 volts are returned to terminal PSO of ignition control.
- Motor stops.
- Ignition control module sends 115 volts to hot surface igniter.
 - Igniter reaches ignition temperature in 17 seconds.
- Ignition control restarts the fan motor while sending 24 VAC to air proving switch.
 - Switch closes and 24 volts are returned back to control.
- Ignition control send 24 volts from terminal GV to high limit switch.
 - If limit switch contacts are closed, limit sends 24 volts to gas control valve
- Gas control valve opens
 - Ignition occurs.
- Flame sense current is passed through burner flame back to ignition control.
- Igniter stays powered until ignition control proves flame sense
 - Igniter then shuts down.
 - Gas control valve stays open
- Room warms to desired temperature.
 - Thermostat is satisfied.
 - Heater shuts down.
- Process starts again on a call for heat.

IGNITION TRIAL SEQUENCE:

- First trial for ignition takes approximately 30 seconds
- Two more ignition trials occur
 - Second trial immediately follows if first trial failed.
 - If second trial fails
 - Ignition control starts a 15 minute waiting period
 - Allows the ignition interruption to pass
- At end of 15 minutes
 - Ignition control attempts third and final ignition trial
 - If ignition control does not prove burner flame after third trial, the control goes into safety lockout (3 flash)
 - Gas valve closes.
 - Hot surface igniter shuts down
 - Fan motor stops.
- To retry for ignition, turn the heater off and then on.

LED Constant On → Normal Operation

Problem

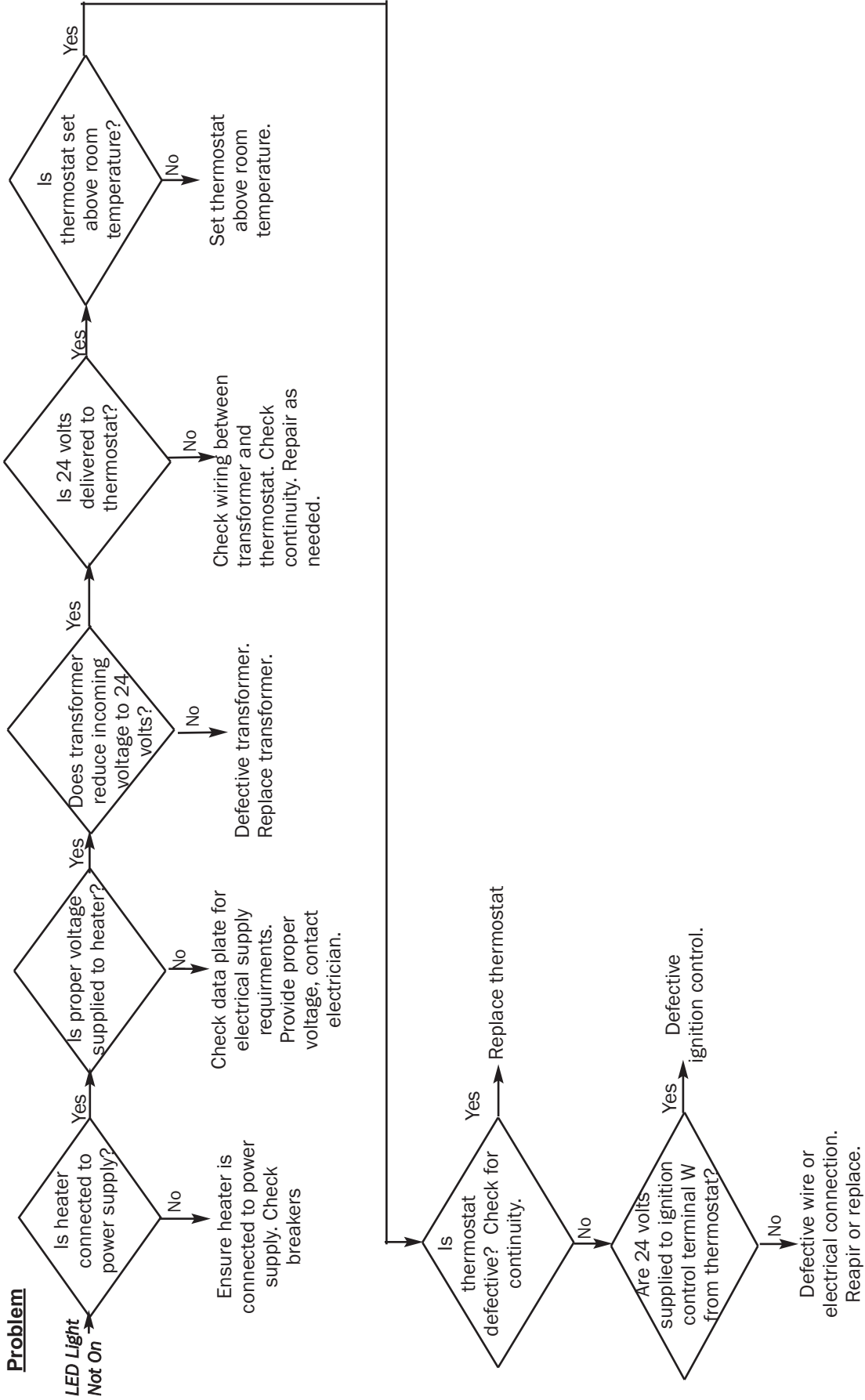

Problem**LED Flashing**

Rapid Flash → Reverse polarity. Have electrician check neutral and hot wire connections that outlet heater is connected to.

Long Flash → Heater has attempted two ignition trials. Heater is in a 15 minute wait period before attempting its third (final) trial for ignition. If ignition is not achieved after the third trial, the heater will lock out and the ignition control module will present the three time flash pattern. Either recycle the heater or wait for heater to attempt third ignition trial.

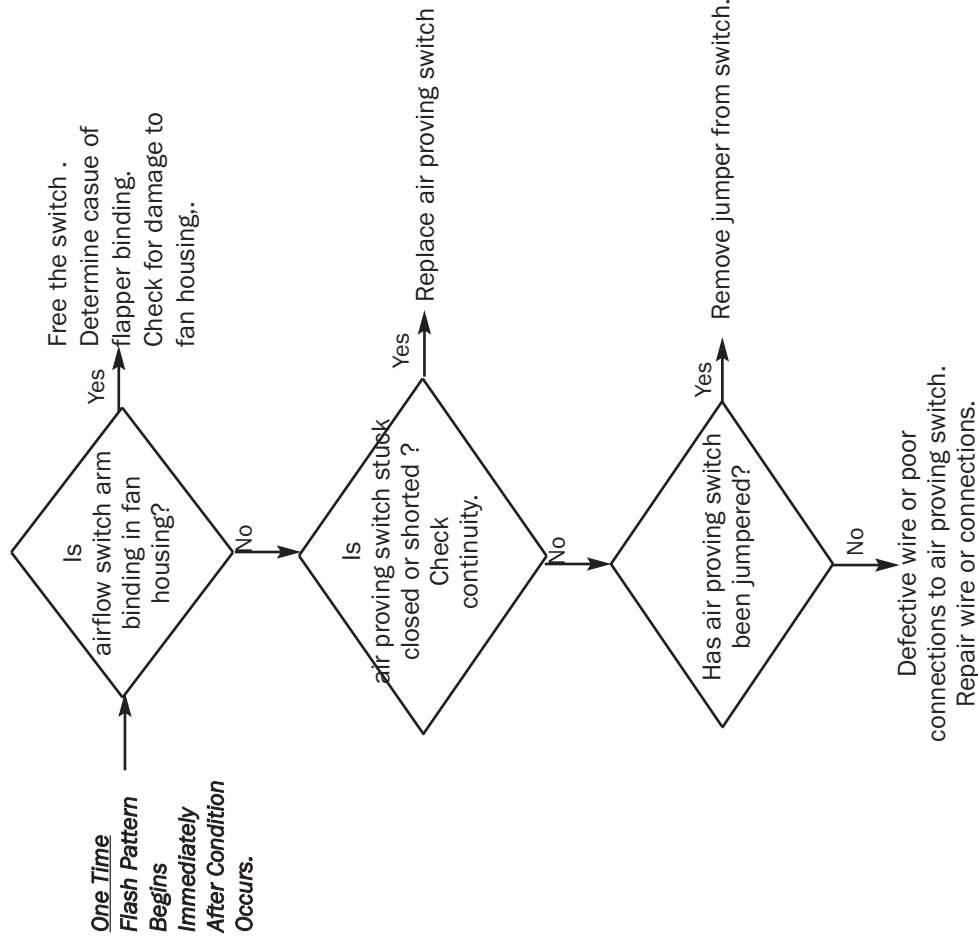

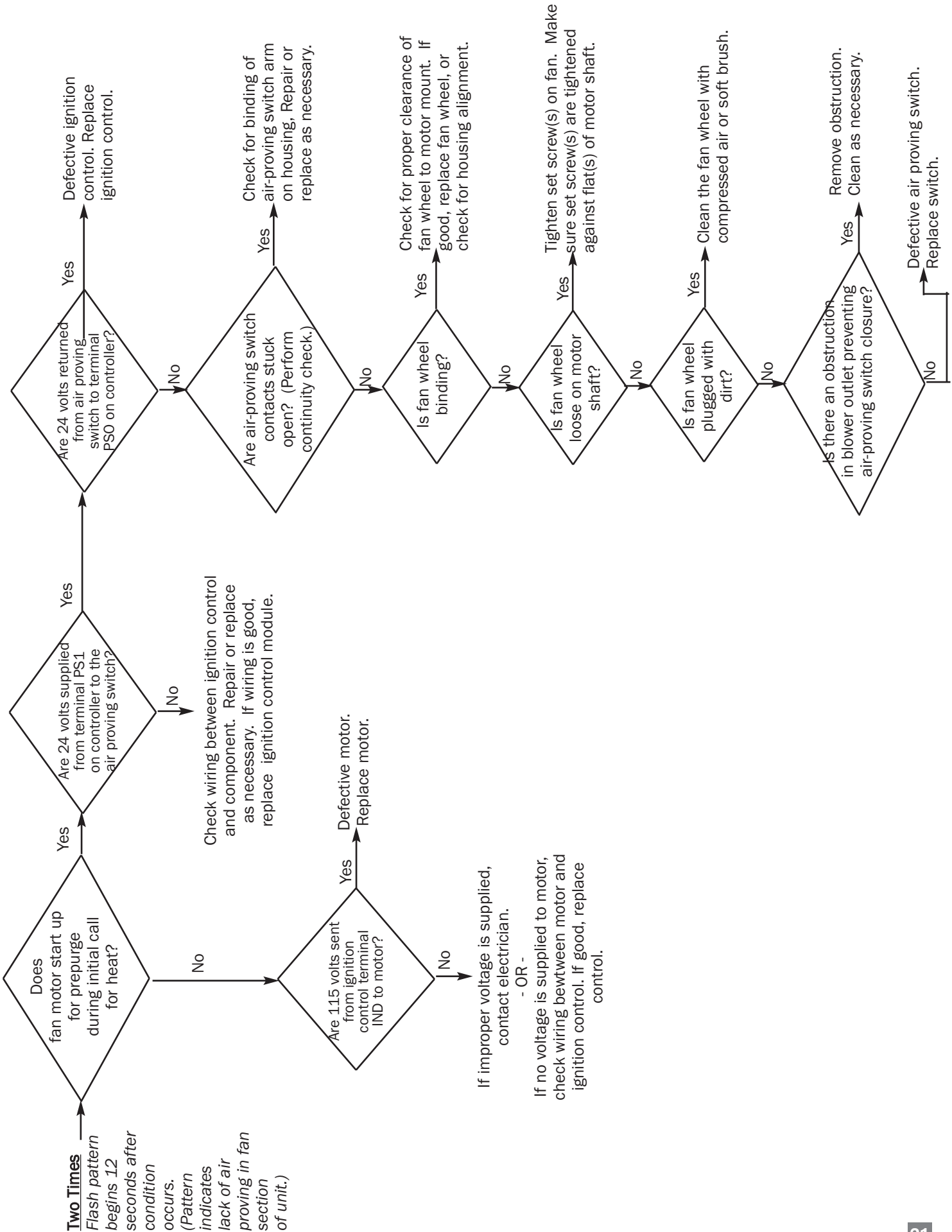

Three Times

Ignition failure
Heater does not light or stay lit.

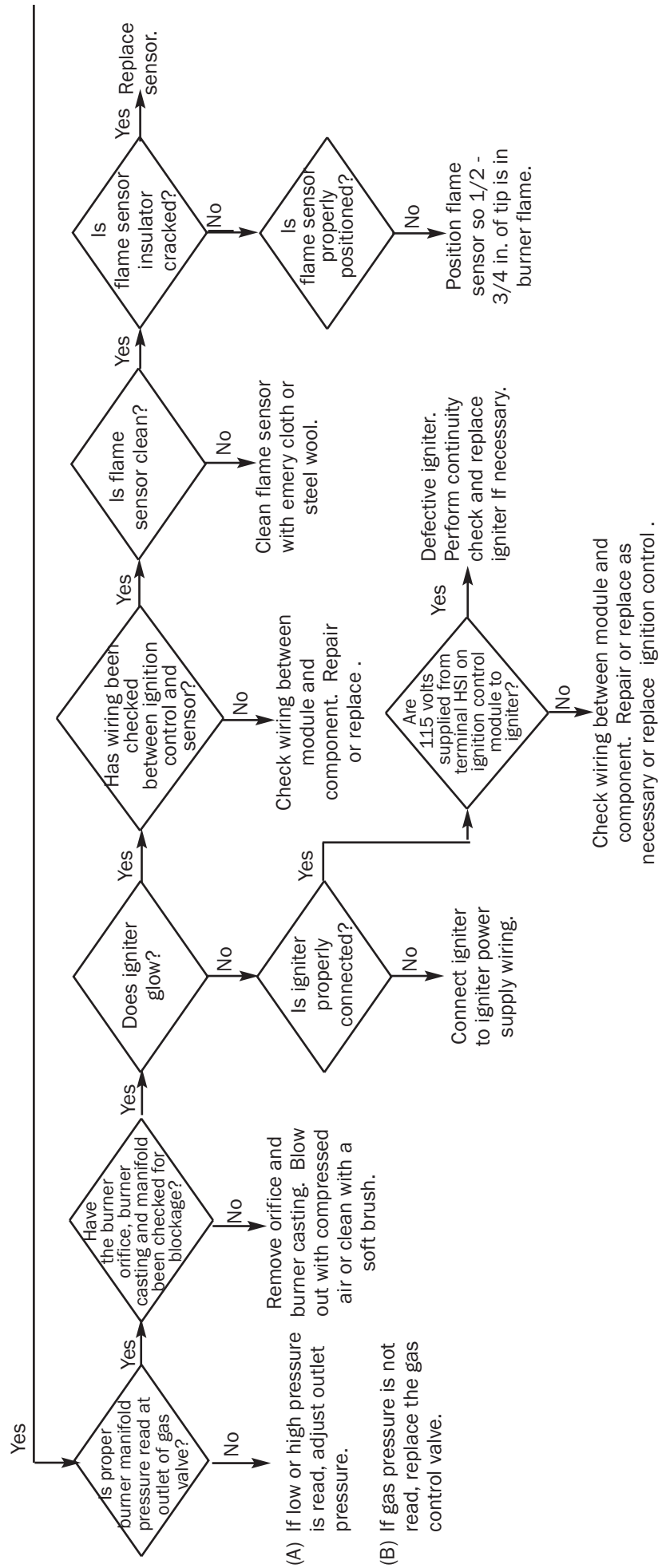
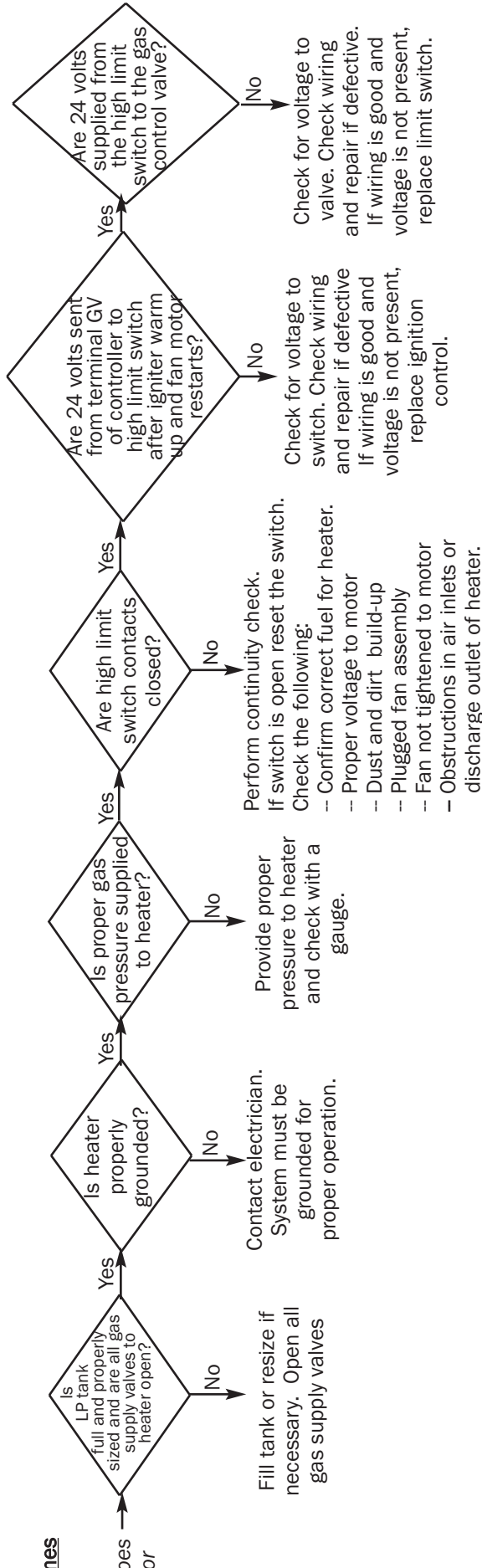

(A) If low or high pressure is read, adjust outlet pressure.
(B) If gas pressure is not read, replace the gas control valve.

Four Times —————> If HSI board does not reset, then replace the board. (Internal board fault.)
If HSI board resets, then have qualified electrician check power source for power quality problems. (Frequency, line noise, line spikes, loose connections, too small wire gauge.)

Five Times —————> See flame sensor related problems in three time flash pattern.

Rapid On/Off cycling of the burner.

Six Times —————> Low microamp output from flame sensor. The heater will continue to operate as normal. Flame sense is low and that flame failure or improper operation can occur at any time. See flame sensor related problems in three time flash pattern.

Electrical Connection and Ladder Diagram

CAUTION - REFER TO THE HEATER'S ELECTRICAL CONNECTION DIAGRAM WHEN SERVICING TO AVOID WIRING ERRORS & HEATER MALFUNCTION. CHECK FOR PROPER OPERATION AFTER SERVICING.

WARNING: THIS HEATER MAY START AT ANY TIME

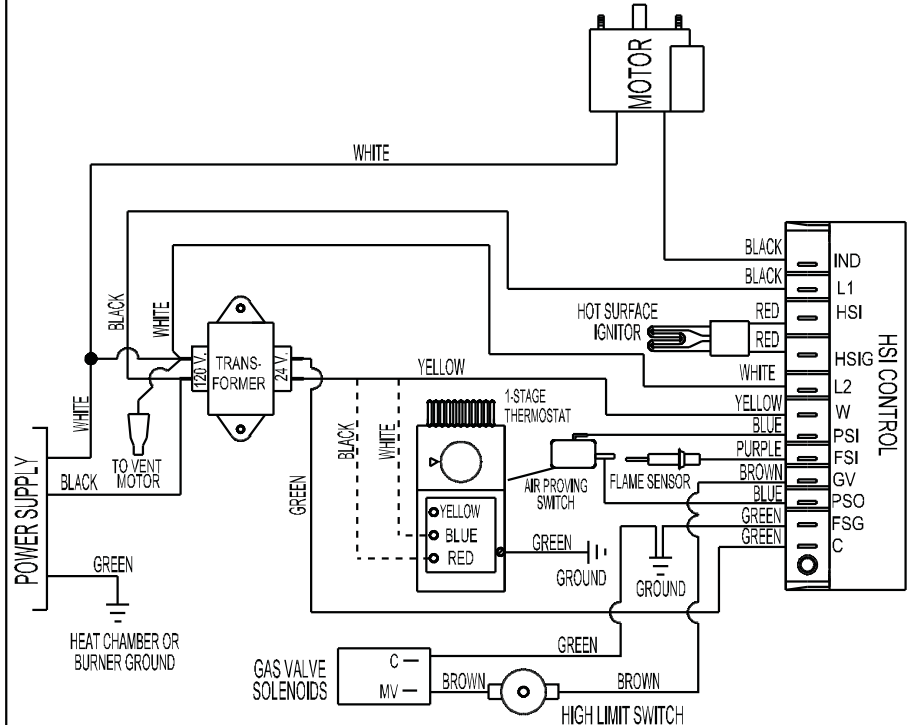

ELECTRICAL CONNECTION DIAGRAM

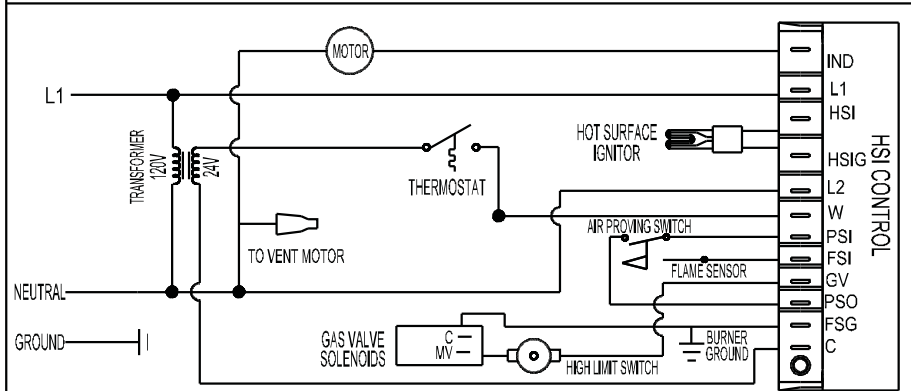

ELECTRICAL LADDER DIAGRAM

IF ANY OF THE ORIGINAL WIRES AS SUPPLIED WITH THE HEATER MUST BE REPLACED, IT MUST BE REPLACED WITH WIRING MATERIAL HAVING A TEMPERATURE RATING OF AT LEAST 302° F (150°C)

Heater Component Function

Air Proving Switch

Safety device used to insure that the proper air flow is being achieved before the gas valve is opened.

Burner

Cast iron component used to channel gas and provide an area at which the fuel may ignite.

Burner Orifice

Brass metering device used to feed gas to burner at a specific rate.

Fan Housing

Chamber used for delivering air for efficient air movement.

Fan Wheel

Component used in conjunction with the motor and fan housing to pull the hot air from heater and blow it into room for heating (also known as a squirrel cage).

Gas Control Valve

A device which consists of a low pressure regulator and electrical solenoids which are used for the control of gas flow to the burner assembly. A feature of the control is a built in gas shut off which is used to isolate the heater from its gas supply when servicing.

Gas Hose

Flexible connector used to convey gas from supply line in building to heater.

Heat Chamber

Metal "fire box" within the appliance that provides an area where burner flame mixes with combustion air, thereby providing heat.

High Limit Switch

Safety device wired into the control system which is used to break an electrical circuit to the gas control valve in event of overheat situation.

Hot Surface Igniter

Ignition device used on automatic ignition control systems. Ignites gas by surface temperature rather than spark or flame.

Ignition Control Module

Electronic printed circuit board which sends and receives voltages to various controls in an automatic ignition system. An important safety feature of the control board is that it will shut down the entire heater, thereby stopping the flow of fuel gas if burner flame goes out.

Motor

Electric device used to force preheated air through the heater and to circulate heat within a certain area. Converts electrical energy into mechanical energy.

Regulator

Mechanical device used in L.P. and natural gas distribution systems to reduce a higher inlet pressure to a preset lower pressure. The regulator is responsible to supply a steady outlet pressure to the heater(s) despite changes in inlet pressure, heater demand and weather conditions.

Thermostat (Accessory)

Electrical device used as an automatic "on/off" switch which will respond to changes in temperature in a certain area. Can be wired so contacts in the thermostat open or close on temperature increase or decrease.

Transformer

Electrical control used to accept line power supply primary voltage and reduce it to lower secondary voltage to operate certain control systems.

Parts Identification

PARTS SCHEMATIC

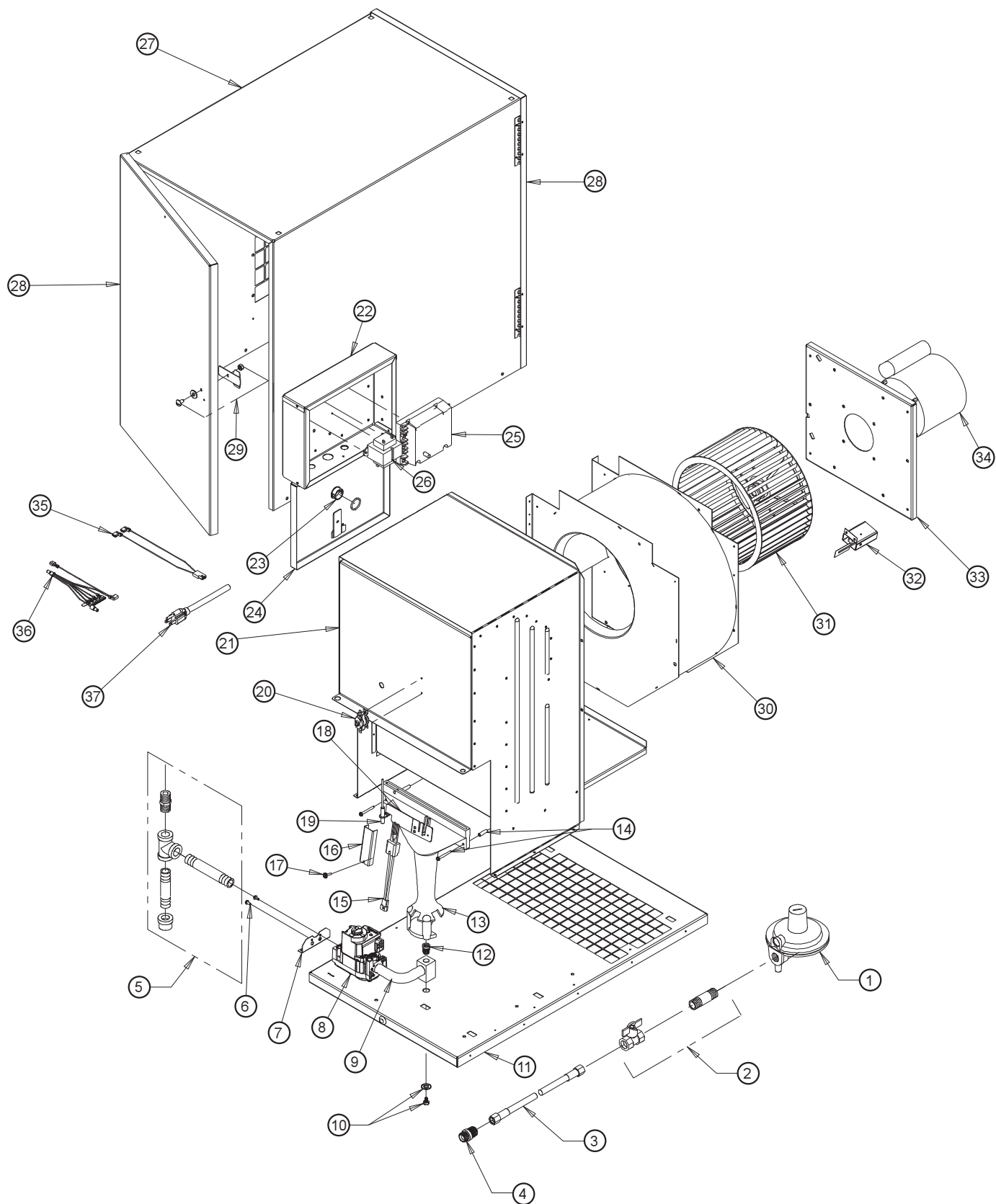

Parts Identification

PARTS LIST

Item	Description	Part Number
1	Regulator, LP Gas, 2nd Stage, Vent Over Outlet	06553
	Regulator, LP Gas, 2nd Stage, Vent Over Side	06665
	Regulator, Natural Gas (5 PSIG Inlet, 13.5 Outlet)	24414
2	Valve, Manual Shut Off with Nipple.	03399
3	Hose, 1/2 in. x 10 ft. Rigid x Swivel	20714
4	Adapter, Hose, 1/2 NPT x 1/2 NPS	25873
5	Kit, Sediment Trap	00815
6	Screws, (2)	570502
7	Bracket with Screws	570141
8	Valve, Gas Control	LP Gas 572471
		Natural Gas 23838
9	Manifold with Orifice	LP Gas 572465
		Natural Gas 572470
10	Washer and Bolt	25866
11	Base	572464
12	Orifice	LP Gas 572469
		Natural Gas 572577
13	Burner with Mounting Hardware	572575
14	Spacers and Screws	570211
15	Igniter, Hot Surface	509201
16	Shield, Igniter	572494
17	Screw and Washer, Igniter Shield	572512
18	Bracket w/ Screws	570089
19	Flame Sensor	520139
20	High Limit Switch	82689
21	Heat Chamber	572466
22	Control Box with Cover	572485
23	Window with O-Ring	570002
24	Cover, Control Box	572483
25	Ignition Control	509298
26	Transformer	509615
27	Case Assembly with Labels	LP Gas 572473
		Natural Gas 572474
28	Door, Access	570874
29	Latch Kit	570228
30	Fan Housing with Motor Mount and Air Proving Switch	572462
31	Fan Wheel	570481
32	Air Proving Switch	09925
33	Motor Mount	572461
34	Motor	520169
35	Wire Harness, Red, Hot Surface Ignitier	572503
36	Wire Harness, White	572579
37	Power Cord	520133

Warranty Policy

HEATER

L.B. White Co., Inc. warrants that the component parts of its heater are free from defects in material and workmanship, when properly installed, operated, and maintained in accordance with the Installation and Maintenance Instructions, safety guides and labels contained with each unit. If, **within 12 months from the date of purchase by the end user**, any component is found to be defective, L.B. White Co., Inc. will at its option, repair or replace the defective part or heater, with a new part or heater, F.O.B., Onalaska, Wisconsin.

A warranty card on file at L.B. White will automatically qualify a unit and its component parts for warranty consideration. If a warranty card is not on file, a copy of the bill of sale will be required to establish warranty qualification. If neither is available, the warranty period will be 12 months from date of shipment from L.B. White.

PARTS

L.B. White Co., Inc. warrants that replacement parts purchased from the company and used on the appropriate L. B. White equipment are free from defects both in material and workmanship for **12 months from the date of purchase by the end user**. Warranty is automatic if a component is found defective within 12 months of the date code marked on the part. If the defect occurs more than 12 months later than the date code but within 12 months from the date of purchase by the end user, a copy of a bill of sale will be required to establish warranty qualification.

duration to the duration of the applicable warranty stated above. The remedies set forth above are the sole and exclusive remedies available hereunder. L.B. White will not be liable for any incidental or consequential damages directly or indirectly related to the sale, handling or use of the equipment, and in any event L.B. White's liability in connection with the equipment, including for claims based on negligence or strict liability, is limited to the purchase price.

The warranty set forth above is the exclusive warranty provided by L.B. White, and all other warranties, including any implied warranties or merchantability or fitness for a particular purpose, are expressly disclaimed. In the event any implied warranty is not hereby effectively disclaimed due to operation of law, such implied warranty is limited in

Some states do not allow limitations on how long an implied warranty lasts, so the above limitation may not apply to you. Some states do not allow the exclusion or limitation of incidental or consequential damages, so the above limitation or exclusion may not apply to you. This warranty gives you specific legal rights, and you may also have other rights which vary from state to state.

Replacement Parts and Service

Contact your local L.B. White dealer for replacement parts and service or call the L.B. White Co., Inc. at 1-800-345-7200 for assistance. Be sure that you have your heater model number and configuration number when calling.