



Owner's Manual and Instructions

Tradesman Kerosene Heaters



MODELS	OUTPUT (BTUH)	FUEL
CP125CK	125,000	1-K Kerosene
CP170CK	170,000	
CP210CK	210,000	

Certification by:



Congratulations!

You have purchased the finest kerosene portable forced air construction heater available.

Your new L.B. White heater incorporates the benefits from the most experienced manufacturer of heating products using state-of-the-art technology.

We, at L.B. White, **thank you** for your confidence in our products and welcome any suggestions or comments you may have...call us, toll-free, at (800) 345-7200.

he requirements of Standard ANSI A10.10-1998, CAN/CSA B140.87 and CSA

ATTENTION ALL USERS

This heater has been tested and evaluated by C.S.A. International in accordance with the requirements of Standard UL733 and ANSI A10.10-1998, CAN/CSA B140.0-03 and CSA B140.8 - 1967 and is listed and approved as a Kerosene forced-air construction heater with application for the temporary heating of buildings under construction, alteration, or repair. If you are considering using this product for any application other than its intended use, then please contact the L.B. White Co., Inc.



Quality heaters you can count on.

W6636 L.B. White Rd., Onalaska, WI 54650 ■ (800) 345-7200 ■ (608) 783-5691 ■ (608) 783-6115, fax ■ info@lbwhite.com

 **GENERAL HAZARD WARNING**

- Failure to comply with the precautions and instructions provided with this heater, can result in:
 - Death
 - Serious bodily injury or burns
 - Property damage or loss from fire or explosion
 - Asphyxiation due to lack of adequate air supply or carbon monoxide poisoning
 - Electrical shock
- Read this Owner's Manual before installing or using this product.
- Only properly-trained service people should repair or install this heater.
- Save this Owner's Manual for future use and reference.
- Owner's Manuals and replacement labels are available at no charge. For assistance, contact L.B. White at 800-345-7200.

 **WARNING**

Fire and Explosion Hazard

- Not for home or recreational vehicle use.
- Installation of this heater in a home or recreational vehicle may result in a fire or explosion.
- Fire or explosions can cause property damage or loss of life.

FOR YOUR SAFETY

Do not store or use gasoline or other flammable vapors and liquids in the vicinity of this or any other appliance.

 **WARNING**

Fire and Explosion Hazard

- Keep solid combustibles a safe distance away from the heater.
- Solid combustibles include wood, paper, or plastic products, building materials and dust.
- Do not use the heater in spaces which contain or may contain volatile or airborne combustibles.
- Volatile or airborne combustibles include gasoline, solvents, paint thinner, dust particles or unknown chemicals.
- Failure to follow these instructions may result in a fire or explosion.
- Fire or explosions can lead to property damage, personal injury or loss of life.



Table of Contents

SECTION	PAGE
General Information	3
Heater Specifications	4
Safety Information	
Hazard Definitions	5
General Safety Information	5
Installation & Assembly	
Heater Specifications	7
Assembly	8
Operation	
Overview of Heater Design	9
The Safety System	9
Fuel Specifications	9
Fueling Your Heater	10
To Start Heater	10
To Shutdown Heater	10
To Restart Heater	10
Extra Electrical Outlet	10
Longterm Storage of Your Heater	11
Maintenance	
Fuel Tank	12
Air Input Filter	12
Air Output /Lint Filter	12
Fan Blades	12
Nozzle	13
Spark Plug	14
Photocell	14
Fuel Filter	15
Pump Pressure Adjustment	15
Replacing Fuse	16
Wiring Diagram	17
Troubleshooting	18
Parts Identification	
Parts Schematic (CP125CK & CP170CK)	19
Parts List (CP125CK & CP170CK)	20
Parts Schematic (CP210CK)	21
Parts List (CP210CK)	22
Parts Schematic (Handles/Wheels)	23
Warranty Information	24

General Information

This Owner's Manual includes all options and accessories commonly used on this heater.

When calling for technical service assistance, or for other specific information, always have model number, configuration number and serial number available. This information is contained on the dataplate.

This manual will instruct you in the operation and care of your unit. Have your qualified installer review this manual with you so that you fully understand the heater and how it functions.

The installation, repair, and servicing of the heater requires continuing expert training and knowledge of kerosene heaters and should not be attempted by anyone who is not so qualified.

Contact your local L.B. White distributor or the L.B. White Co., Inc. for assistance, or if you have any questions about the use of the equipment or its application.

The L.B. White Co., Inc. has a policy of continuous product improvement. It reserves the right to change specifications and design without notice.

Heater Specifications

Model

SPECIFICATIONS	CP125CK	CP170CK	CP210CK
Fuel Type	1-K, Kerosene		
Max Input (BTUH)	125,000	170,000	210,000
Ventilation Air Required to Support Combustion	520 CFM	600 CFM	650 CFM
Pump Pressure (PSIG)	5.5	6.5	8.5
Fuel Consumption per Hour (gal)	.95	1.3	1.6
Motor Characteristics	Ball Bearing		
	1/5HP 3455 RPM	1/4HP 3430 RPM	1/3HP 3380 RPM
Electrical Supply (Voltz/Hz/Phase)	120/60/1		
Amp Draw	CONTINUOUS OPERATION 2.5	3.2	3.7
Length x Width x Height	36 ¹ / ₁₀ " x 23 x 24 ⁶ / ₁₀ "	41 ⁸ / ₁₀ " x 24 ⁶ / ₁₀ " x 26 ¹ / ₁₀ "	
Minimum Safe Distances From Nearest Combustible Materials	Top	4 ft.	
	Sides	4 ft.	
	Back	4 ft.	
	Blower Outlet	8 ft.	
	Bulk Fuel Storage Container	25 ft.	
Net Weight (lbs.)	50.7	56.9	59.1
Shipping Weight (lbs.)	58	65.7	67.9
Minimum Ambient Temperature in which Heater may be used	-20°F		

Safety Information

HAZARD DEFINITIONS



DANGER

Indicates an imminently hazardous situation which, if not avoided *WILL* result in death or serious injury.



WARNING

Indicates a potentially hazardous situation which, if not avoided, *COULD* result in death or serious injury.



CAUTION

Indicates a potentially hazardous situation which, if not avoided, *MAY* result in minor or moderate injury.

GENERAL SAFETY INFORMATION



WARNING

Before using this heater, please read this USER'S MANUAL very carefully. This USER'S MANUAL has been designed to instruct you as to the proper manner in which to assemble, maintain, store, and most importantly, how to operate the heater in a safe and efficient manner.



WARNING

Never leave the heater unattended while burning!



DANGER

Improper use of this heater can result in serious injury or death from burns, fire, explosion, electrical shock, and/or carbon monoxide poisoning.

GENERAL SAFETY INFORMATION (cont.)



WARNING

Risk of CO Poisoning!

- Use this heater only in well ventilation areas. Provide proper ventilation. See heater specifications (page 4).
- Never use this heater in living or sleeping areas.
- Carbon Monoxide Poisoning: Early signs of carbon monoxide poisoning resemble flu-like symptoms such as headaches, dizziness, and/or nausea. If you have these symptoms, your heater may not be working properly.
- Get fresh air at once! Have the heater serviced.
- People with breathing problems should consult a physician before using the heater.



WARNING

Risk of Electric Shock!

- Use only the electrical power (voltage and frequency) specified on the model plate of the heater. Use only a threeprong, grounded outlet and extension cord.
- ALWAYS install the heater so that it is not directly exposed to water spray, rain, dripping water, or wind.
- ALWAYS unplug the heater when not in use.

CALIFORNIA RESIDENTS: This heater produces carbon monoxide, which is listed by the State of California as a reproductive toxin under Proposition 65.

MASSACHUSETTS RESIDENTS: Massachusetts state law prohibits the use of this heater in any building which is used in whole or in part for human habitation. Use of this heating device in Massachusetts requires local fire dept. permit (M.E.L.C. 148, Section 10A).

CANADIAN RESIDENTS: Use of this heater shall be in accordance with authorities having jurisdiction and CSA Standard B139.

NEW YORK CITY RESIDENTS: For use only at construction sites in accordance with applicable NYC codes under NYCFD certificate of approval #5034 and 5037



WARNING

Risk of Burns/Fire/Explosion!

- Keep all combustible materials away from this heater.
Minimum Clearances
Outlet 8 feet (250 cm)
Sides, Top and Rear 4 feet (125 cm)
- NEVER use fuels such as gasoline, benzene, paint thinners, or other oil compounds in this heater (RISK OF FIRE OR EXPLOSION).
- NEVER use this heater where flammable vapors may be present.
- NEVER refill the heater's fuel tank while heater is operating or still hot. This heater is EXTREMELY HOT while in operation.
- NEVER block air inlet (rear) or air outlet (front) of heater.
- NEVER use duct work in front or at rear of heater.
- NEVER move or handle heater while still hot.
- NEVER transport heater with fuel in its tank.
- When used with optional thermostat or if equipped with a thermostat, the heater may start at any time.
- ALWAYS locate heater on a stable and level surface.
- Use 1-K kerosene in this heater. #1 fuel oil is a suitable substitute.
- Bulk fuel storage should be a minimum of 25 ft. from heaters, torches, portable generators, or other sources of ignition. All fuel storage should be in accordance with federal, state, or local authorities having jurisdiction.

Installation and Assembly Instructions

HEATER SPECIFICATIONS

Introduction

Please read this USER'S MANUAL carefully. It will show you how to assemble, maintain and operate this heater safely and efficiently to obtain the full benefits of its many features.

Consumer: Retain these instructions for future reference.

Unpacking

1. Remove all packing items applied to heater for shipment.
2. Remove all items from carton.
3. Check all items for shipping damage.
If heater is damaged, promptly inform dealer where you purchased heater.

Dimensions

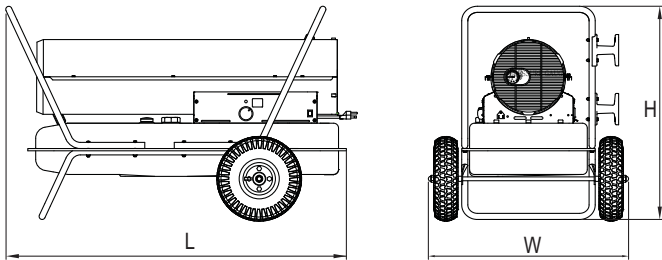

Figure 1 - Heater Dimensions

	CP125CK	CP170CK CP210CK
Height	24.6"	26.1"
Length	36.1"	41.8"
Width	23"	24.6"

Product Features

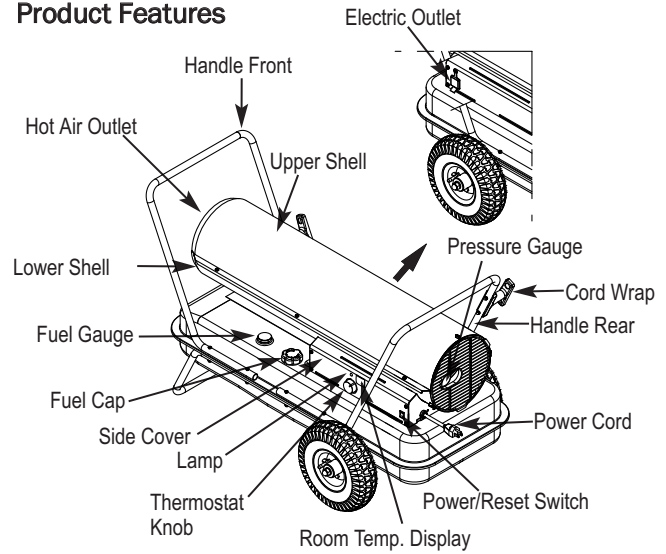

Figure 2 - Features

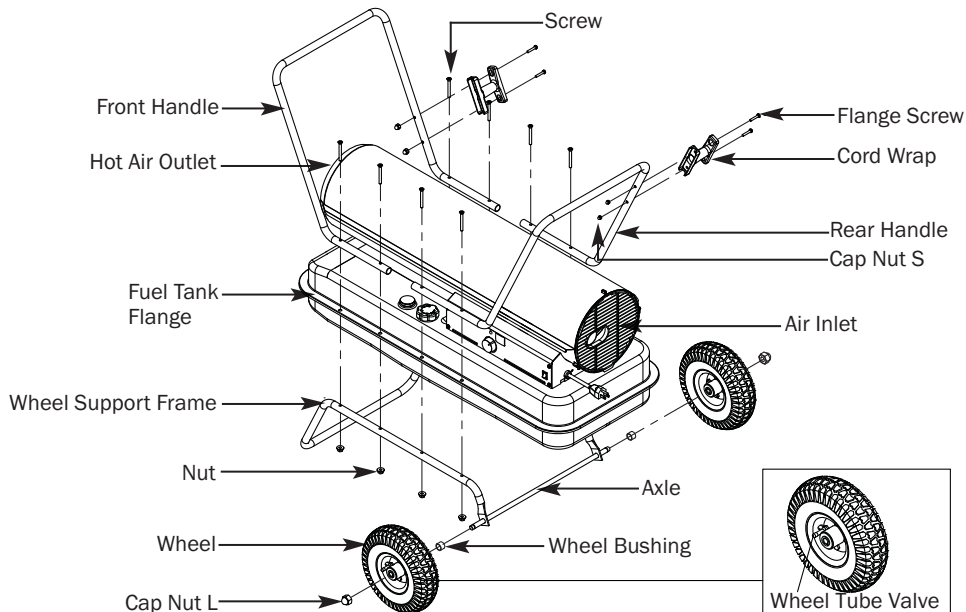

Figure 3 - Assembly

Installation and Assembly Instructions

ASSEMBLY

TOOLS REQUIRED

- Medium Phillips screwdriver.
- M5 open, or adjustable wrench.

1. Slide threaded axle through the rear section of the wheel support frame.

NOTE : When installing wheels, tube valve should face out from support frame (Figure 3).

2. Slide one axle bushing on to each side of the axle. Slide one wheel on to each side of the axle. .

3. Attach one cap nut on to each side of the threaded axle and tighten well

4. Place heater on wheel support frame. Make sure the air inlet end (rear) of heater is over wheels. Align the holes on fuel tank flange. Insert screws through handles (front and rear), fuel tank flange, and wheel support frame as shown in Figure 3 and attach nut finger tight after each screw is inserted.

5. After all screws are inserted, tighten nuts firmly.

6. Align the hole on the handle (front and rear) with the mounting hole on the cord wrap.

7. Insert screws through cord wrap, handles as shown in Figure 4 and attach nut finger tight after each screw is inserted.

8. After all screws are inserted, tighten nuts firmly.

USE CAUTION WHEN INFLATING TIRES:

- Do NOT over inflate tire. Maximum air pressure is 36 PSI.
- Over inflation may lead to serious injury
- NEVER fill tires using an air compressor. A manual pump is recommended

⚠ WARNING

Fire or explosion hazard!

- Do not operate heater without support frame fully assembled to tank.

Model	CP125CK	CP170CK	CP210CK
Wheel Support Frame	Yes	Yes	Yes
Wheels	Yes	Yes	Yes
Front-Handle	Yes	Yes	Yes
Rear-Handle	Yes	Yes	Yes
Axle	Yes	Yes	Yes
Cord Wrap	Yes	Yes	Yes
Hardware Kit	Yes	Yes	Yes

CP125CK / CP170CK / CP210CK

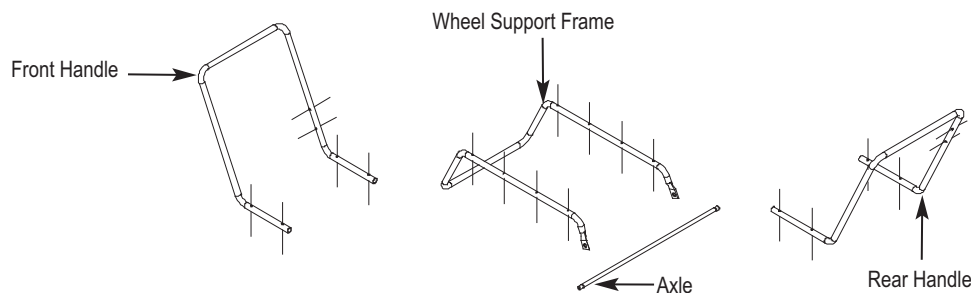
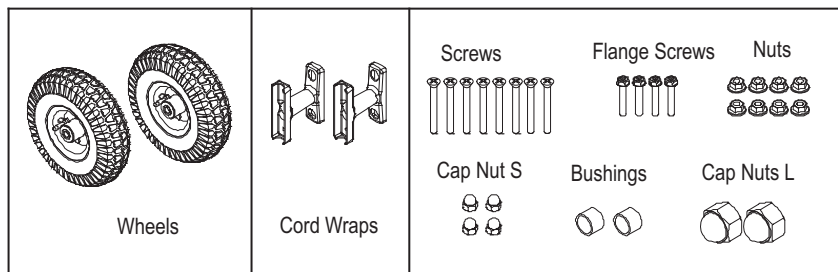

Figure 4 – Component Identification

OPERATION

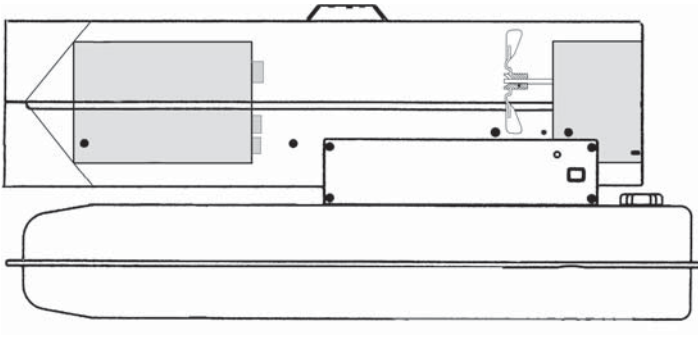

Figure 5 – Overview of Heater Design

OVERVIEW OF HEATER DESIGN

Fuel System: This heater is equipped with an electric air pump that forces air through the air line connected to the fuel intake, and then through a nozzle in the burner head. When air passes in front of the fuel intake, it causes fuel to rise from the tank and into the burner nozzle.

This fuel and air mixture is then sprayed into the combustion chamber in a fine mist.

SureFire Ignition: The electronic ignitor sends voltage to a specially designed spark plug. The spark plug ignites the fuel and air mixture described above.

The Air System: The heavy duty motor turns a fan that forces air into and around the combustion chamber. Here, the air is heated and then forced out the front of the heater.

THE SAFETY SYSTEM

Temperature Limit Control: This heater is equipped with a Temperature Limit Control designed to turn the heater off should the internal temperature rise to an unsafe level. If this device activates and turns your heater off, it may require service.

Once the temperature falls below the reset temperature, you will be able to start your heater.

Model	Internal Shut-off Temp. +/-10 Degrees	Reset Temp. +/-10 Degrees
CP125CK/CP170CK	230°F/110°C	194°F/90°C
CP210CK	194°F/90°C	140°F/60°C

Electrical System Protection: This heater's electrical system is protected by a fuse mounted to the PCB Assembly that protects it and other electrical components from damage. If your heater fails to operate, check this fuse first and replace as needed. Refer to Specification chart on page 4.

Flame-Out Sensor: Utilizes a photocell to monitor the flame in burn chamber during normal operation. It will cause the heater to shut off should the burner flame extinguish.

FUEL SPECIFICATIONS

KEROSENE (1-K)

For optimal performance of this heater, it is strongly suggested that 1-K kerosene be used. 1-K kerosene has been refined to virtually eliminate contaminants, such as sulfur, which can cause a rotten egg odor during the operation of the heater. However, #1 or #2 fuel oil (diesel fuel) may also be used if 1-K kerosene is not available. **Be advised that these fuels do not burn as clean as 1-K kerosene, and care should be taken to provide more fresh air ventilation to accommodate any added contaminants that may be added to the heated space.**



WARNING!

Fire and explosion hazard!

- Kerosene should only be stored in a blue container that is clearly marked "kerosene". Never store kerosene in a red container. Red is associated with gasoline.
- NEVER store kerosene in the living space. Kerosene should be stored in a well ventilated area outside the living area.
- NEVER use fuel such as gasoline, benzene, alcohol, white gas, camp stove fuel, paint thinners, or other oil compounds in this heater (THESE ARE VOLATILE FUELS THAT CAN CAUSE A FIRE OR EXPLOSION).
- NEVER store kerosene in direct sunlight or near a source of heat.
- NEVER use kerosene that has been stored from one season to the next. Kerosene deteriorates over time. **OLD KEROSENE WILL NOT BURN PROPERLY IN THIS HEATER.**
- Use 1-K kerosene in this heater. #1 fuel is a suitable substitute.

FUELING YOUR HEATER

Never fill the heater fuel tank in the living space: fill the tank outdoors.

Do not overfill your heater and be sure heater is level.



WARNING

Fire and explosion hazard!

Never refill fuel tank when heater is operating or still hot.

IMPORTANT: REGARDING FIRST IGNITION OF HEATER. The first time you light the heater, it should be done OUTDOORS. This allows the oils, etc., used in manufacturing heater to be burned off outside.

TO START HEATER

1. Fill fuel tank with kerosene or No. 1 fuel oil.
2. Attach fuel cap.
3. Plug power cord into three prong, grounded extension cord. Extension cord must be at least six feet long.
 - Extension Cord Wire Size Requirements:
 - 6 to 100 feet (1.8 to 30.53 meters) long, use 16 AWG conductor.
 - 101 to 200 feet (30.8 to 61 meters) long, use 14 AWG conductor.
4. Turn thermostat control knob to desired setting and push power switch to "ON" position. Power lamp will light and heater will start.

NOTE: Room Temp. display indicates as following:

- When room temp. is less than 0°F: "lo".
- When room temp. is between 0°F and 99°F: Indicates in figure.
- When room temp is greater than 99°F: "Hi"

If heater does not start, the thermostat setting may be too low. Turn THERMOSTAT CONTROL KNOB to higher position to start heater. If heater still does not start, turn power switch to "OFF" and then to "ON" position (See Figure 6). If heater still does not start, see Troubleshooting on page 18.

NOTE: The major electrical components of this heater are protected by a safety fuse mounted to the PCB board. If your heater fails to start, check this fuse first and replace as necessary. You should also check your power source to insure that proper voltage and frequency are being supplied to the heater.

TO SHUT DOWN HEATER

Turn switch to "OFF" and unplug power cord.

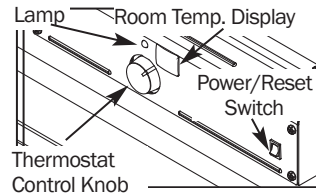

Figure 6 – Controls

TO RESTART HEATER

1. Wait 10 seconds after stopping heater.
2. Repeat steps under, "TO START HEATER."

EXTRA ELECTRICAL OUTLET

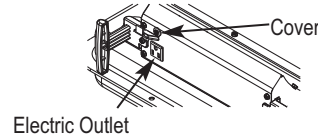

Figure 7 – Electric Outlet



WARNING

SHOCK HAZARD!

- Always cover electric outlet when not in use. Don't plug and use an appliance of more than 5A current in this outlet.

OPERATION (cont.)

LONG-TERM STORAGE OF YOUR HEATER

FUEL TANK DRAIN

1. Remove drain bolt from bottom of fuel tank. See Figure 8.

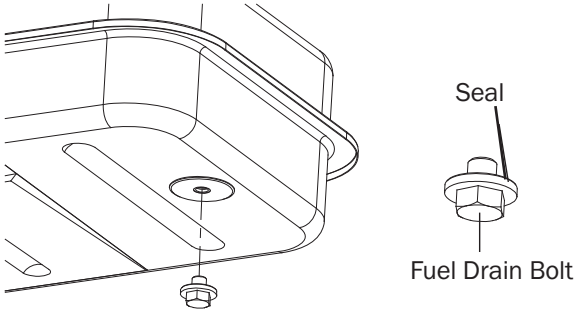

Figure 8 – Drain Plug Removal

2. Using a small amount of kerosene, swirl and rinse the inside of the tank.

NEVER MIX WATER WITH KEROSENE, as it will cause rust inside the tank. Pour the kerosene out, making sure that you remove it all.

IMPORTANT:

Do not store kerosene over summer for use during next heating season. Using old fuel may damage heater.

Tighten drain bolt firmly into the tank, otherwise it will not seal completely.

- Make sure storage place is free of dust and corrosive fumes.
- Store the heater in the original box with the original packing material and keep USER'S MANUAL with heater..

USE ORIGINAL EQUIPMENT REPLACEMENT PARTS. Use of third-party or other alternate components will void warranty and may cause unsafe operating conditions.



WARNING

Fire or explosion hazard!

- Never service heater while it is plugged in or while hot!

FUEL TANK

Flush every 200 hours of operation or as needed (See Long-term Storage, page 11).

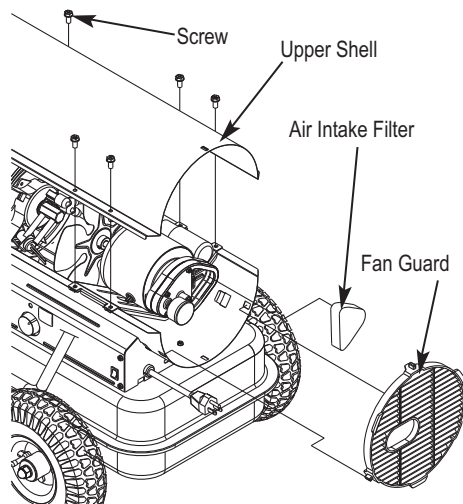

Figure 9 - Air Filter Access

AIR INTAKE FILTER

WASH AND DRY WITH SOAP AND WATER EVERY 500 HOURS OF OPERATION, OR AS NEEDED.

- Remove screws along each side of heater using medium Phillips screwdriver.
- Lift off upper shell.
- Remove fan guard.
- Wash or replace air intake filter.
- Reinstall fan guard and upper shell.

AIR OUTPUT FILTER, LINT FILTER

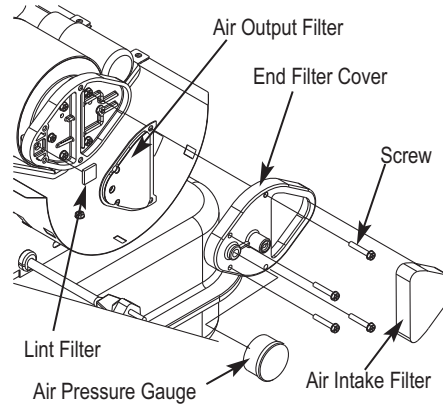

Figure 10 - Filter Assembly

REPLACE EVERY 500 HOURS OF OPERATION OR ONCE A YEAR

- Remove upper shell and fan guard (See Air Intake Filter Figure 9).
- Turn air pressure gauge counter-clockwise and remove.
- Remove end filter cover screws using medium Phillips screwdriver.
- Remove end filter cover.
- Replace air output and lint filter.
- Reinstall end filter cover and air pressure gauge.
- Reinstall fan guard and upper shell.

FAN BLADES

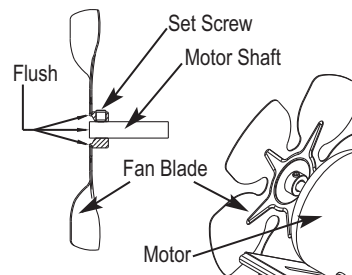

Figure 11 - Fan Assembly

CLEAN EVERY SEASON OR AS NEEDED

- Remove upper shell (See Air Intake Filter).
- Use M6 Allen wrench to loosen set screw which holds fan blade to motor shaft.
- Slip fan blade off motor shaft.
- Clean fan blade using soft cloth moistened with kerosene or solvent.
- Dry fan blade thoroughly.
- Reinstall fan blade to motor shaft.
- Place fan blade hub flush with end of motor shaft.
- Place set screw on flat of shaft.
- Tighten screw firmly (40-50 inch-pounds/4.5-5.6 N-m).
- Reinstall upper shell.

MAINTENANCE (cont.)

NOZZLE

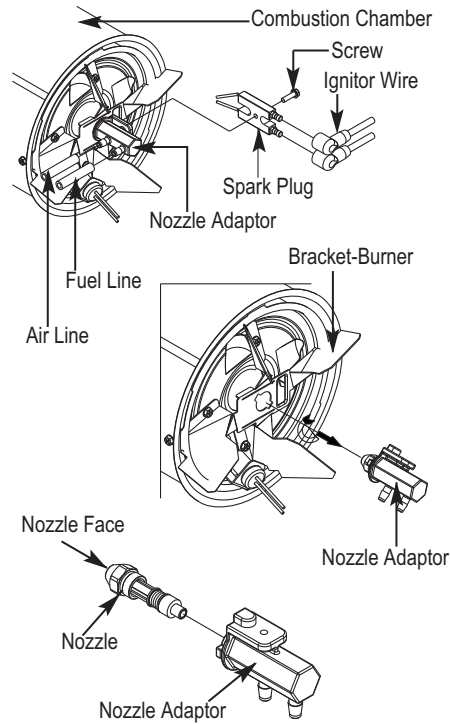
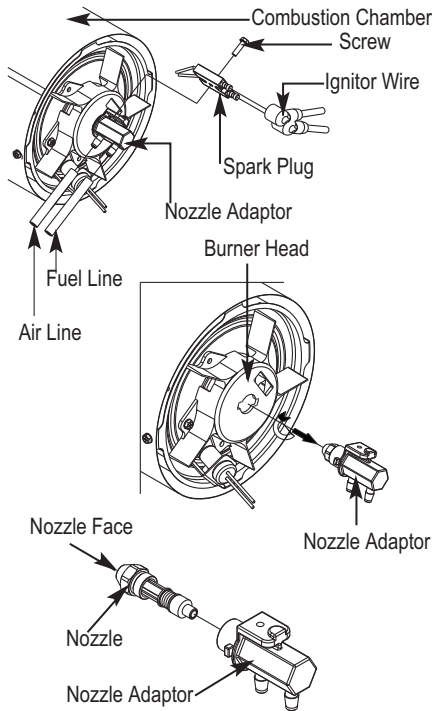

Figure 12 – Nozzle Replacement For Models CP125CK and CP170CK

CLEAN NOZZLE AS NEEDED

(For Models CP125CK and CP170CK only)

- Remove upper shell (See Air Intake Filter, page 12).
- Remove fan blade (See Fan Blades).
- Remove fuel and air line hoses from nozzle adaptor.
- Remove ignitor wire from spark plug.
- Remove spark plug from nozzle adaptor using medium phillips screwdriver.
- Turn nozzle adaptor 1/9 turn (40°) to counter clock wise and pull toward motor to remove. (See Figure 12)
- Place plastic hex-body into vise and lightly tighten.
- Carefully remove nozzle from burner head using 5/8" socket wrench.
- Blow compressed air through face of nozzle. (this will remove any dirty in nozzle)
- Reinstall nozzle into nozzle adaptor until nozzle seats. Tighten 1/3 turn more using 5/8" socket wrench. (40~45 inch-pounds)
- Reinstall nozzle adaptor to burner head.
- Reinstall spark plug to nozzle adaptor.
- Attach ignitor wire to spark plug.
- Attach fuel and air line hoses to nozzle adaptor.
- Reinstall fan blade and upper shell.

Figure 13 – Nozzle Replacement CP210CK

(For Model CP210CK Only)

- Remove upper shell (See Air Intake Filter, page 12).
- Remove fan blade (See Fan Blades).
- Remove fuel and air line hoses from nozzle adaptor.
- Remove ignitor wire from spark plug.
- Remove spark plug from nozzle adaptor using medium phillips screwdriver.
- Turn nozzle adaptor 1/8 turn (45°) to counter clock wise and pull toward motor to remove. (See Figure 13)
- Place plastic hex-body into vise and lightly tighten.
- Carefully remove nozzle from adaptor-nozzle using 5/8" socket wrench.
- Blow compressed air through face of nozzle. (this will remove any dirt in nozzle)
- Reinstall nozzle into nozzle adaptor until nozzle seats. Tighten 1/3 turn more using 5/8" socket wrench (40~45 inch-pounds)
- Reinstall nozzle adaptor to burner bracket
- Reinstall spark plug to nozzle adaptor.
- Attach ignitor wire to spark plug.
- Attach fuel and air line hoses to nozzle adaptor.
- Reinstall fan blade and upper shell.

SPARK PLUG

CLEAN AND REGAP EVERY 600 HOURS OF OPERATION OR REPLACE AS NEEDED.
 CLEAN AND REGAP EVERY 600 HOURS OF OPERATION OR REPLACE AS NEEDED.

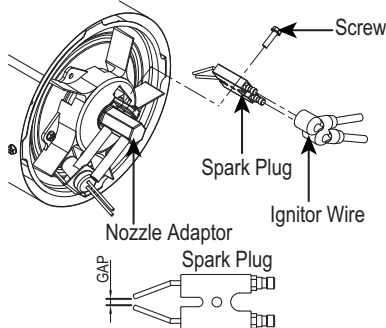

Figure 14 – Spark Plug Replacement

- (For Models CP125CK and CP170CK only)
- Remove upper shell (See Air Intake Filter, page 12).
 - Remove fan (See Fan Blades).
 - Remove ignitor wire from spark plug.
 - Remove spark plug from nozzle adaptor using mediumphillips screwdriver.
 - Clean and regap spark plug electrodes to 3.5mm gap.
 - Reinstall spark plug to nozzle adaptor.
 - Attach ignitor wire to spark plug.
 - Reinstall fan and upper shell.

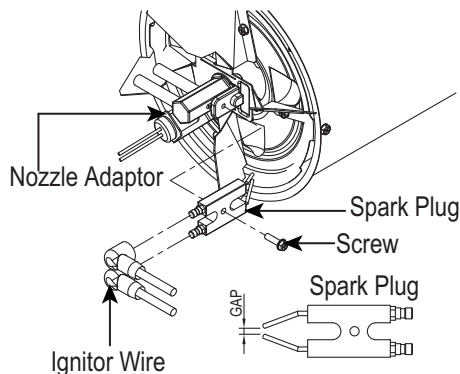

Figure 15 – Spark Plug Replacement

- (For Model CP210CK only)
- Remove upper shell (See Air Intake Filter, page 12).
 - Remove fan (See Fan Blades).
 - Remove ignitor wire from spark plug.
 - Remove spark plug from nozzle adaptor using mediumphillips screwdriver.
 - Clean and regap spark plug electrodes to 3.5mm gap.
 - Reinstall spark plug to nozzle adaptor.
 - Attach ignitor wire to spark plug.
 - Reinstall fan and upper shell.

PHOTOCELL

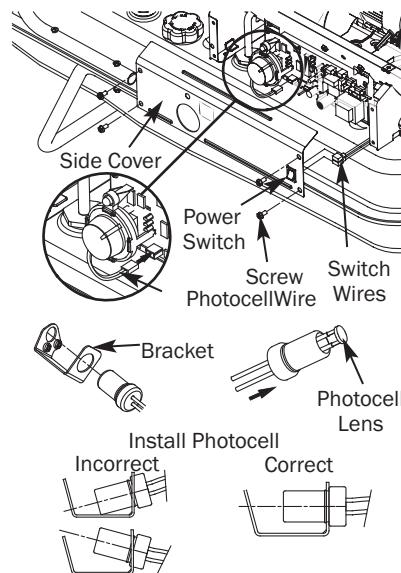

Figure 16 – Photocell Replacement

- CLEAN PHOTOCELL ANNUALLY OR AS NEEDED.
- Remove upper shell (See Air Intake Filter, page 12)
 - Remove fan (See Fan Blades)
 - Remove photocell from its mounting bracket.
 - Clean photocell lens with cotton swab.
 - TO REPLACE: Remove side cover near power switch.
 - Disconnect wires from power switch and remove side cover.
 - Disconnect wires from circuit board and remove photocell.
 - Install new photocell and attach wires to circuit board.
 - Replace switch wires to power switch and side cover.
 - Replace fan and upper shell.

MAINTENANCE (cont.)

FUEL FILTER

CLEAN OR REPLACE TWICE PER HEATING SEASON OR AS NEEDED.

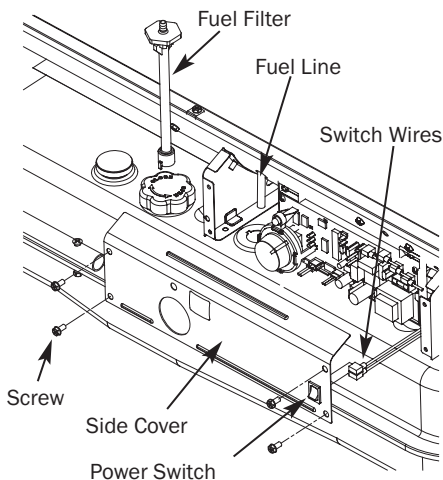

Figure 17 – Fuel Filter Replacement

- Remove side cover screws using medium Phillips screwdriver.
- Disconnect switch wires from power switch and remove side cover.
- Pull fuel line off fuel filter neck.
- Turn fuel filter clockwise 90 degrees and pull to remove.
- Wash fuel filter with clean fuel and replace in tank.
- Attach fuel line to fuel filter neck.
- Reinstall side cover.

PUMP PRESSURE ADJUSTMENT

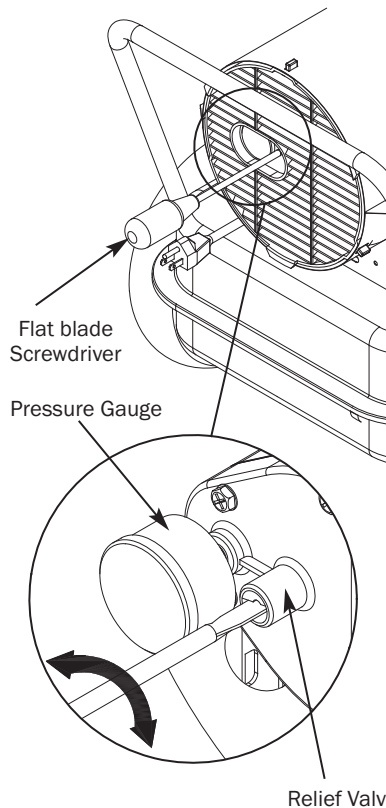

Figure 18 – Adjusting Pump Pressure

- Start heater (See “Operation”, page 10).
- Allow motor to reach full speed.
- Adjust pressure (using flat blade screwdriver).
- Turn relief valve clockwise to increase pressure.
- Turn relief valve counterclockwise to decrease pressure.
- Set pump pressure to correct pressure for each model.
- Stop heater (see “Operation”, page 10).

Model	Pump Pressure
CP125CK	5.5 PSI
CP170CK	6.5 PSI
CP210CK	8.5 PSI

NOTE: USE ONLY ORIGINAL EQUIPMENT REPLACEMENT PARTS. Use of alternate or third party components will void warranty and may cause an unsafe operating condition.

REPLACING FUSE

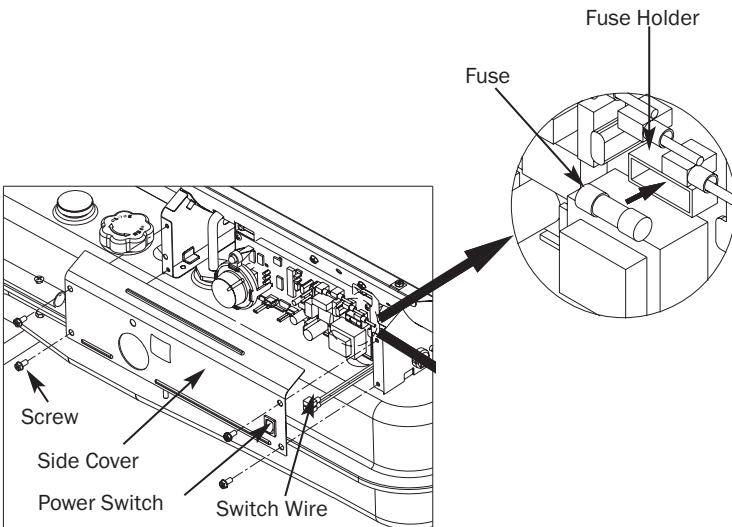

Figure 19 – Replacing Fuse

NOTE: The heater is fuse protected. If your heater fails to ignite, **DO NOT RETURN YOUR HEATER TO THE STORE.** Please follow the simple instructions below to inspect and change the fuse.

- Unplug heater.
- Remove side cover screws using medium Phillips screwdriver.

⚠ WARNING
Burn hazard!

- **SHOCK HAZARD.** To prevent personal injury, unplug the power cord before replacing fuse.

- Disconnect switch wires from power switch.
- Remove fuse from fuse holder (See Figure 19).
- Replace fuse with enclosed fuse.
- Replace switch wires to power switch.
- Replace side cover.

NOTE: Specified fuse rating: AC 125/8A, part number 572447

WIRING DIAGRAM

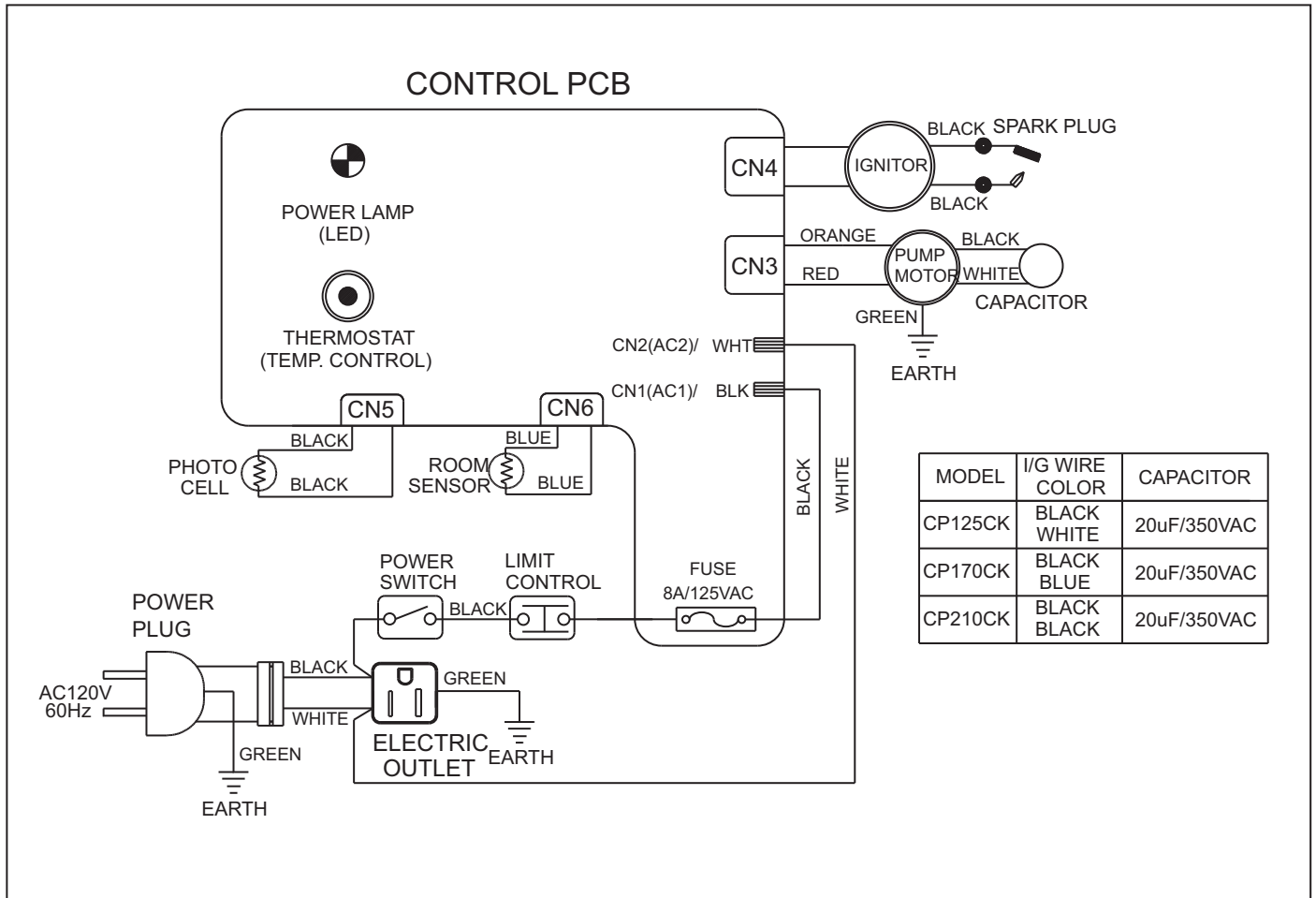

Figure 21 - Wiring Diagram Models CP125CK, CP170CK, CP210CK

Troubleshooting Chart

Symptom	Possible Cause(s)	Corrective Action
Heater ignites but MAIN PCB assembly shuts heater off after a short period of time. (Indicator Lamp is flickering and room temp. display indicates "E1")	<ol style="list-style-type: none"> 1. Wrong pump pressure 2. Dirty Air Output, Air Intake or Lint Filter 3. Dirty Fuel Filter 4. Dirt in Nozzle 5. Dirt Photocell Lens 6. Photocell Assembly not Properly Installed (not seeing the flame) 7. Bad electrical connection between photocell and MAIN PCB Assembly 8. Defective photocell 	<ol style="list-style-type: none"> 1. See Pump Pressure Adjustment, page 15 2. See Air Output, Air Intake and Lint Filters, page 12 3. See Fuel Filter, page 15 4. See Nozzle, page 13 5. Clean Photocell Lens, page 14 6. Make sure photocell boot is properly seated in bracket, Page 14 7. Check electrical components. See Wiring Diagrams, page 17 8. Replace Photocell, page 14
Heater will not ignite but motor runs for a short period of time. (Indicator Lamp is flickering and room temp. display indicates "E1")	<ol style="list-style-type: none"> 1. No fuel in tank 2. Wrong pump pressure 3. Carbon deposits on spark plug and/or improper gap 4. Dirty fuel filter 5. Dirt in Nozzle 6. Water in fuel tank 7. Bad electrical connection between igniter and MAIN PCB Assembly 8. Igniter wire is not attached to spark plug 	<ol style="list-style-type: none"> 1. Fill tank with kerosene 2. See Pump Pressure Adjustment, page 15 3. See Spark Plug, page 14 4. See Fuel Filter, page 15 5. See Nozzle, page 13 6. Flush fuel tank with clean kerosene, page 11 7. Check electrical components. See Wiring Diagram, page 17 8. Attach igniter to spark plug. See Spark Plug, page 14
Fan does not turn when heater is plugged in and power switch was in the "ON" position. (Indicator Lamp is on or flickering)	<ol style="list-style-type: none"> 1. Thermostat setting is too low 2. Bad electrical connection between motor and MAIN PCB Assembly 	<ol style="list-style-type: none"> 1. Turn thermostat control knob to a higher setting 2. Check electrical connections. See Wiring Diagram, page 17
(Indicator Lamp is flickering and room temp. display indicates "E2")	<ol style="list-style-type: none"> 1. Room Temp. sensor disconnected 	<ol style="list-style-type: none"> 1. Reconnect sensor. See Wiring Diagrams, page 17
(Indicator Lamp is flickering and room temp. display indicates "E3")	<ol style="list-style-type: none"> 2. Sensor Failure 	<ol style="list-style-type: none"> 2. Replace sensor. See Wiring Diagram, page 17
Heater will not turn-on (Indicator Lamp is off)	Thermostat switch failure	Replace MAIN PCB
	<ol style="list-style-type: none"> 1. Temperature limit safety device is overheated 2. No electrical power 3. Blown fuse 4. Bad electrical connection between temperature limit safety device and PCB board 	<ol style="list-style-type: none"> 1. Turn power switch to "OFF" and allow to cool (about 10 min.) 2. Check to insure heater cord and extension cord are plugged in. Check power supply 3. Replace safety fuse in PCB board. See Replacing Fuse, page 16 4. Check electrical connections. See Wiring Diagrams, page 17

Parts Identification

PARTS SCHEMATIC (CP125CK & CP170CK)

For Repair Parts,
call 1-800-345-7200

Please provide following information:

- Model number
- Serial number (if any)
- Part description and number as shown in parts list

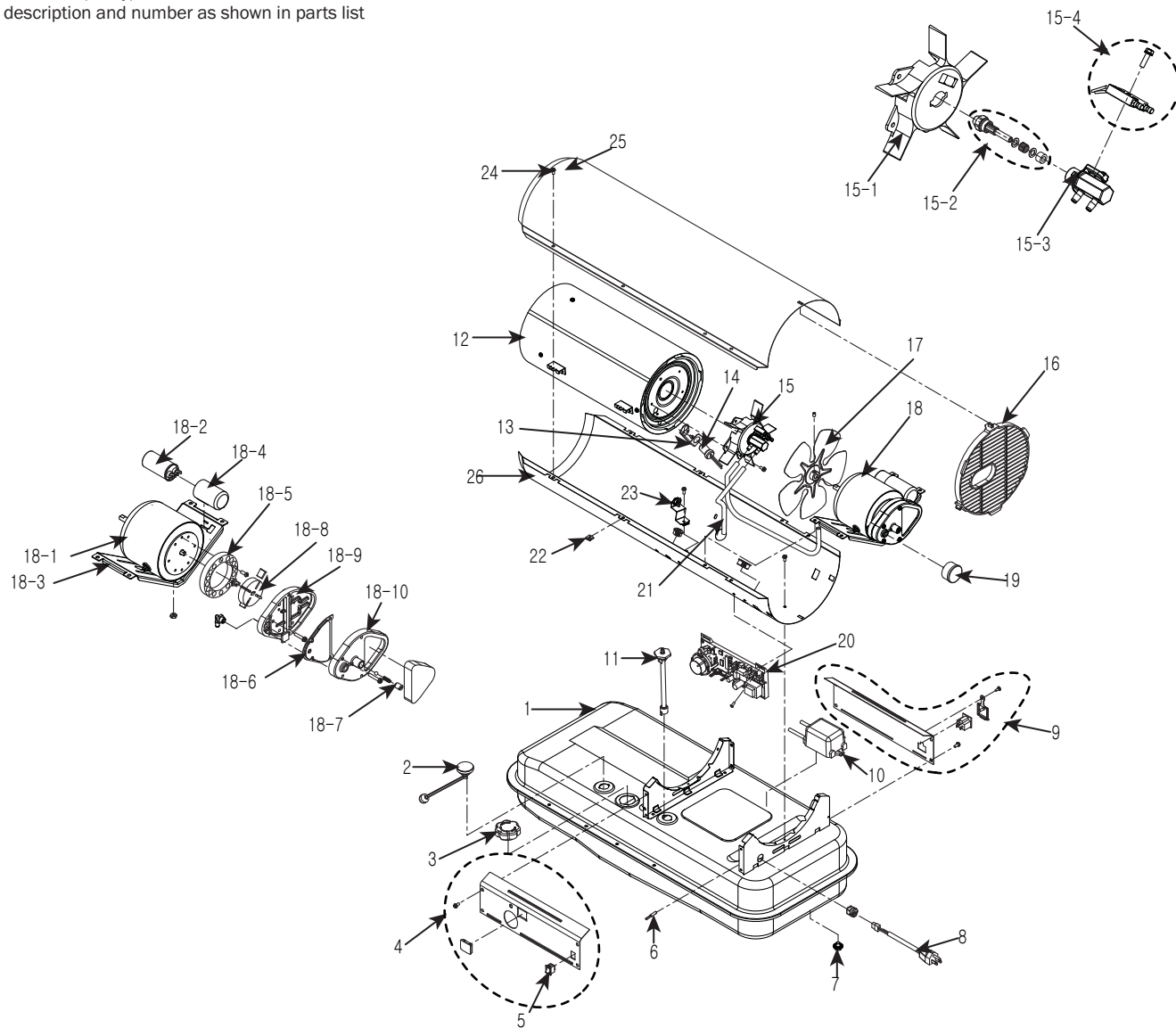

Figure 22- Repair Parts Illustration for Portable Oil-Fired Heaters Models CP125CK, CP170CK

PARTS LIST (CP125CK & CP170CK)

Reference Number	Description	Part Number for Models:	
		CP125CK	CP170CK
1	Fuel Tank Assembly	572707	572714
2	Fuel Gauge	-----572151-----	
3	Fuel Cap	-----572157-----	
4	Panel Right Side Assembly	572258	572261
5	Power Switch	-----572251-----	
6	Thermostat Wire	-----572149-----	
7	Drain Plug	-----572450-----	
8	Power Cord	-----572160-----	
9	Panel Left Side Assembly	572259	572262
10	Ignition Transformer	572244	572245
11	Fuel Filter	-----572155-----	
12	Combustion Chamber	572706	572713
13	Photocell Bracket	-----572185-----	
14	Photocell Assembly	-----572186-----	
15	Burner Head Assembly	See Below	
15-1	Burner Head	572705	572711
15-2	Nozzle Assembly	572194	572195
15-3	Nozzle Adaptor	-----572658-----	
15-4	Spark Plug Assembly	-----572201-----	
16	Fan Guard	-----572266-----	
17	Fan Assembly	572234	572235
18	Motor and Pump Assembly	572659	572660
18-1	Motor	572709	572716
18-2	Capacitor	-----572655-----	
18-3	Motor Support	-----572703-----	
18-4	Capacitor Holder	-----572702-----	
18-5	Pump Body	-----572223-----	
18-6	Filter Kit*	-----572227-----	
18-7	Pump Adjustment Kit***	-----572230-----	
18-8	Rotor Kit**	-----572225-----	
18-9	Pump Cover	-----572696-----	
18-10	Filter Cover	-----572229-----	
19	Pressure Gauge	-----572231-----	
20	Main P.C.B. Assembly	-----572657-----	
21	Air/Fuel Lines	572704	572712
22	Clip Nut (8-Pack)	-----572284-----	
23	Temperature Limit Assembly	-----572727-----	
24	Screw (12-Pack)	-----572282-----	
25	Upper Shell	572710	572717
26	Lower Shell	572708	572715
	Fuse	-----572447-----	
	Hardware Kit	-----572285-----	
	Pump/Filter Cover Screws (10-Pack)	-----572283-----	
	Filter Kit* - Includes Intake, Outlet, and Lint Filter		
	Rotor Kit** - Include Rotor, Blades, and Insert		
	Pump Adjustment Kit*** - Includes Ball Spring and Adjusting Screw		

Parts Identification

PARTS SCHEMATIC (CP210CK)

For Repair Parts,
call 1-800-345-7200

Please provide following information:

- Model number
- Serial number (if any)
- Part description and number as shown in parts list

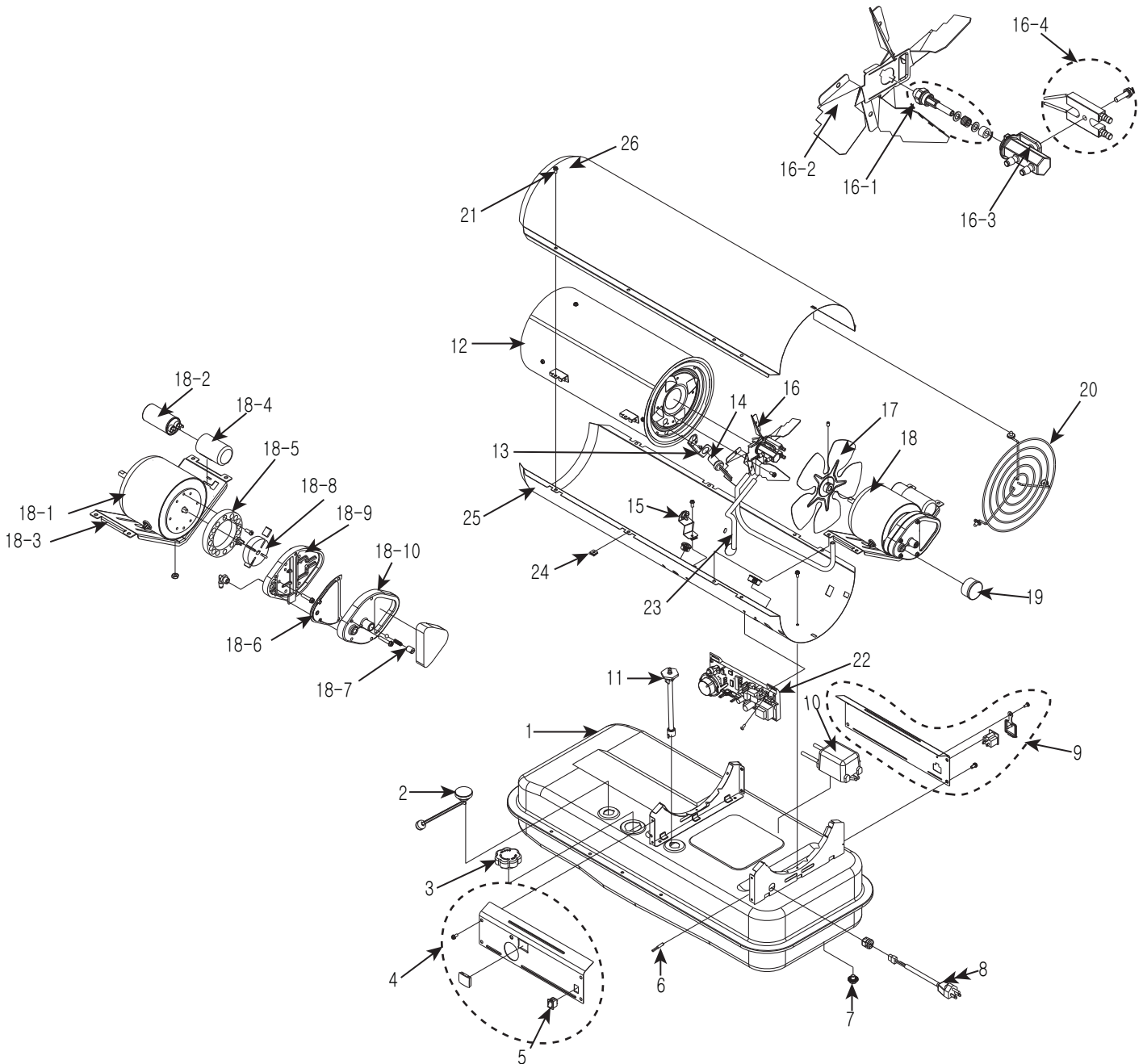

Figure 23 – Repair Parts Illustration for Portable Oil-Fired Heater (Model CP210CK)

PARTS LIST (CP210CK)

Reference Number	Description	Part Number for Models: CP210CK
1	Fuel Tank Assembly	572721
2	Fuel Gauge	572151
3	Fuel Cap	572157
4	Panel Right Side Assembly	572264
5	Power Switch	572251
6	Thermostat Wire	572149
7	Drain Plug	572450
8	Power Cord	572160
9	Panel Left Side Assembly	572262
10	Ignition Transformer	572246
11	Fuel Filter Assembly	572155
12	Combustion Chamber	572720
13	Photocell Bracket	572185
14	Photocell Assembly	572186
15	Temperature Limit Assembly	572725
16	Burner Assembly	See Below
16-1	Nozzle Assembly	572196
16-2	Bracket Burner	572719
16-3	Nozzle Adapter	572662
16-4	Spark Plug Assembly	572202
17	Fan Assembly	572235
18	Motor and Pump Assembly	572661
18-1	Motor	572723
18-2	Motor Support	572703
18-3	Capacitor Holder	572702
18-4	Capacitor	572655
18-5	Pump Body	572224
18-6	Rotor Kit**	572226
18-7	Pump Cover	572696
18-8	Filter Kit*	572227
18-9	Filter Cover	572229
18-10	Pump Adjustment Kit***	572230
19	Pressure Gauge	572231
20	Fan Guard	572267
21	Screw (12-Pack)	572282
22	Main P.C.B. Assembly	572657
23	Air/Fuel Lines	572718
24	Clip Nut (8-Pack)	572284
25	Lower Shell	572722
26	Upper Shell	572724
	Hardware Kit	572285
	Fuse	572447
	Pump/Filter Cover Screws (10-Pack)	572283
	Filter Kit* - Includes Intake, Outlet, and Lint Filter	
	Rotor Kit** - Include Rotor, Blades, and Insert	
	Pump Adjustment Kit*** - Includes Ball Spring and Adjusting Screw	

Parts Identification

PARTS SCHEMATIC HANDLES & WHEELS

For Repair Parts,
call 1-800-345-7200

Please provide following information:

- Model number
- Serial number (if any)
- Part description and number as shown in parts list

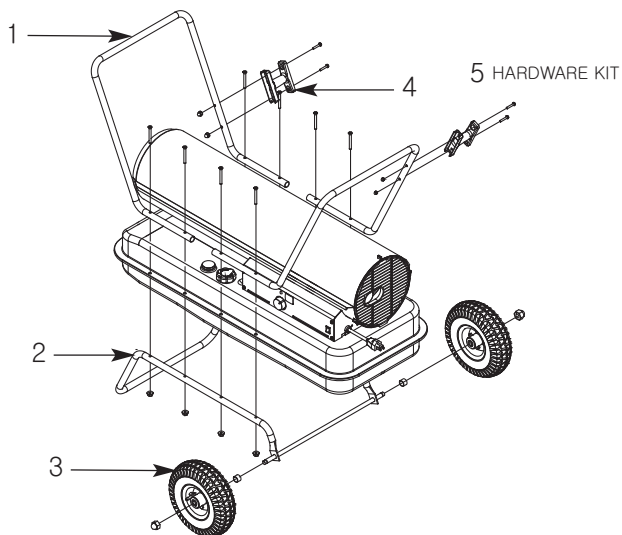

Figure 24- Repair Parts Illustration for Models CP125CK, CP170CK, CP210CK

Replacement Parts List for Models CP125CK, CP170CK, CP210CK

Ref. No.	Description	Part No. for Models:	
		CP125CK	CP170CK & CP210CK
1	Upper Handle Kit	572272	572276
2	Wheel Support/Axle Kit	572273	572277
3	Wheels Kit	572274	
4	Cordwarp Kit	572275	
5	Hardware Kit	572656	

Warranty Policy

EQUIPMENT

L.B. White Co., Inc. warrants that the component parts of its heater are free from defects in material and workmanship, when properly installed, operated, and maintained in accordance with the Owner's Manual safety guides and labels contained with each unit. If, **within 12 months from the date of purchase by the end user**, any component is found to be defective, L.B. White Co., Inc. will at its option, repair or replace the defective part or heater, with a new part or heater, F.O.B., Onalaska, Wisconsin.

A warranty card on file at L.B. White will automatically qualify the heater and its component parts for warranty consideration. If a warranty card is not on file, a copy of the bill of sale will be required to establish warranty qualification. If neither is available, the warranty period will be 12 months from date of shipment from L.B. White.

PARTS

L.B. White Co., Inc. warrants that replacement parts purchased from the company and used on the appropriate L. B. White heater are free from defects both in material and workmanship for **12 months from the date of purchase by the end user**. Warranty is automatic if a component is found defective within 12 months of the date code marked on the part. If the defect occurs more than 12 months later than the date code but within 12 months from the date of purchase by the end user, a copy of a bill of sale will be required to establish warranty qualification.

The warranty set forth above is the exclusive warranty provided by L.B. White, and all other warranties, including any implied warranties or merchantability or fitness for a particular purpose, are expressly disclaimed. In the event any implied warranty is not hereby effectively disclaimed due to operation of law, such implied warranty is limited in

duration to the duration of the applicable warranty stated above. The remedies set forth above are the sole and exclusive remedies available hereunder. L.B. White will not be liable for any incidental or consequential damages directly or indirectly related to the sale, handling or use of the heater, and in any event L.B. White's liability in connection with the heater, including for claims based on negligence or strict liability, is limited to the purchase price.

Some states do not allow limitations on how long an implied warranty lasts, so the above limitation may not apply to you. Some states do not allow the exclusion or limitation of incidental or consequential damages, so the above limitation or exclusion may not apply to you. This warranty gives you specific legal rights, and you may also have other rights which vary from state to state.

Replacement Parts and Service

Contact your local L.B. White dealer for replacement parts and service or call the L.B. White Co., Inc. at (800) 345-7200 for assistance. Be sure that you have your heater model number and configuration number when calling.