



Owner's Manual and Instructions

Modulating Infraconic Agricultural Building Radiant Heaters



MODELS	OUTPUT (Btuh)	FUEL
I40	40,000	Propane Vapor Withdrawal or Natural Gas



Congratulations!

You have purchased the finest radiant heater available for the heating of livestock in agricultural animal confinement buildings.

Your new L.B. White radiant heater incorporates the benefits from the most experienced manufacturer of heating products using state-of-the-art technology.

We, at L.B. White, **thank you** for your confidence in our products and welcome any suggestions or comments you may have...call us toll free at 1-800-345-7200.

ATTENTION ALL USERS

This heater has been tested and evaluated by L.B. White Co., Inc. as a direct gas-fired radiant heater with intended use for the heating of livestock in agricultural animal confinement buildings. If you are considering using this product for any application other than its intended use, then please contact your fuel gas supplier, or the L.B. White Co., Inc.



Quality heaters you can count on.

W6636 L.B. White Rd., Onalaska, WI 54650 ■ (800) 345-7200 ■ (608) 783-5691 ■ (608) 783-6115, fax ■ info@lbwhite.com

 **GENERAL HAZARD WARNING**

- Failure to comply with the precautions and instructions provided with this heater, can result in:
 - Death
 - Serious bodily injury or burns
 - Property damage or loss from fire or explosion
 - Asphyxiation due to lack of adequate air supply or carbon monoxide poisoning
 - Electrical shock
- Read this Owner's Manual before installing or using this heater.
- Only properly-trained service people should repair or install this heater.
- Save this Owner's Manual for future use and reference.
- Owner's Manuals and replacement labels are available at no charge. For assistance, contact L.B. White at 800-345-7200.

 **WARNING**

- Proper gas supply pressure must be provided to the inlet of the heater.
- Refer to rating plate for proper gas supply pressure.
- Gas pressure in excess of the maximum inlet pressure specified at the heater inlet can cause fires or explosions.
- Fires or explosions can lead to serious injury, death, building damage or loss of livestock.
- Gas pressure below the minimum inlet pressure specified at the heater inlet may cause improper combustion.
- Improper combustion can lead to asphyxiation or carbon monoxide poisoning and therefore serious injury or death to humans and livestock.

 **WARNING**

Fire and Explosion Hazard

- Not for home or recreational vehicle use.
- Installation of this heater in a home or recreational vehicle may result in a fire or explosion.
- Fire or explosions can cause property damage or loss of life.

FOR YOUR SAFETY

Do not store or use gasoline or other flammable vapors and liquids in the vicinity of this or any other heater.

FOR YOUR SAFETY

If you smell gas:

1. Open windows.
2. Don't touch electrical switches.
3. Extinguish any open flame.
4. Immediately call your gas supplier.

 **WARNING**

Fire and Explosion Hazard

- Keep solid combustibles a safe distance away from the heater.
- Solid combustibles include wood or paper products, feathers, straw, and dust.
- Do not use the heater in spaces which contain or may contain volatile or airborne combustibles.
- Volatile or airborne combustibles include gasoline, solvents, paint thinner, dust particles or unknown chemicals.
- Failure to follow these instructions may result in a fire or explosion.
- Fire or explosions can lead to property damage, personal injury or loss of life.



Table of Contents

<u>SECTION</u>	<u>PAGE</u>
General Information	3
Heater Specifications	4
Safety Precautions	5
Installation Instructions	
General	7
Gas Train Assembly	9
Zone Control Panel Function and Installation	10
Installing Dust Filter	10
Start-Up Instructions	11
Shut-Down Instructions	11
Cleaning Instructions	
A. Heater	12
B. Filter	13
Maintenance Instructions	14
Service Instructions	
General	14
Safety Gas Control Valve	15
Bypass Orifice (Individual Control)	15
Thermostatic Head	16
Burner Orifices	16
Main Burner Pressure Valve	
A. Removal	17
B. Adjustment	17
Thermocouple	18
Gas Pressure Checks	19
Troubleshooting Guide	20
Heater Component Function	25
Parts Identification	
Parts Schematic	26
Parts List	27
Warranty Policy	28
Replacement Parts and Service	28

General Information

This owner's manual includes all options and accessories commonly used on or with this heater. However, depending on the configuration purchased, some options and accessories may not be included.

When calling for technical service assistance, or for other specific information, always have the model number and serial number available.

This manual will instruct you in the operation and care of your radiant heater. Have your qualified installer review this manual with you so that you fully understand the heater and how it functions.

The gas supply line installation, and the repair, installation and servicing of the heater requires continuing expert training and knowledge of gas heaters and should not be attempted by anyone who is not so qualified. See page 6 for definition of the necessary qualifications.

Contact your local L. B. White distributor or the L. B. White Co., Inc. for assistance, or if you have any questions about the use of the heater or its application.

The L. B. White Co., Inc. has a policy of continuous product improvement. It reserves the right to change specifications and design without notice.

Radiant Heater Specifications

		Model	
		I40	
SPECIFICATIONS			
Maximum Input (Btuh)		40,000	
Ventilation Air to Support Combustion		468 CFM	
Zone Control Full Output Pressure	PROPANE GAS OR NATURAL GAS	5 PSIG	
Zone Control, Low Output Pressure	PROPANE GAS OR NATURAL GAS	10 - 12 in. W.C.	
Heater Dimensions (See Fig. 1)	"A"	31-1/2 in.	
	"B"	20-1/4 in.	
	"C"	10-5/8 in.	
Net Weight		13 lbs.	
Fuel Consumption Per Hour	PROPANE GAS	1.85 lbs./hr.	
	NATURAL GAS	40 CFH	
Animal Coverage Per Heater (1)	CHICKENS	2900 - 4400	
	TURKEYS	920 - 1100	
	SWINE	345	
Recommended Height Installation For Livestock From Point of Combustion Cone to Floor	CHICKENS	6.5 - 7.5 ft.	
	TURKEYS	5.5 - 6.5 ft.	
	SWINE	5 - 6 ft.	
Minimum Safe Clearances to Combustible Materials	TOP OF HOOD TO CEILING	3 ft.	
	POINT OF COMBUSTION CONE TO FLOOR	4.5 ft.	
	SIDES	3 ft.	
Animal Occupied Zone Temperature Control Sensor Location (2)	POULTRY	VERTICAL FROM FLOOR	6-12 in.
		HORIZONTAL FROM BROODER	8-12 ft.
	SWINE	VERTICAL FROM FLOOR	Above Animal Height
		HORIZONTAL FROM BROODER	4-8 ft.

- (1) There are other factors that will affect the quantity of animals each heater can cover. These include building ventilation and control systems, building insulation, building size and population density, etc. Consult your L.B. White dealer or call L.B. White for specific recommendations for your application.
- (2) This is a typical sensor height range for poultry installations. The size and type of livestock being grown, heater spacing and height, etc. will dictate sensor height. Care should always be taken to ensure that the sensor is sufficiently high as to not be damaged by the animal during operation.

FIG. 1

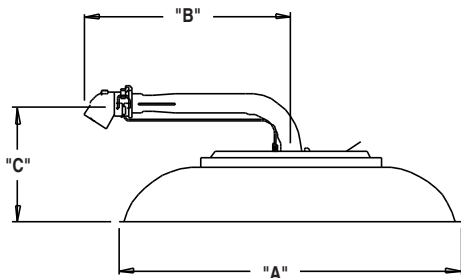

Safety Precautions

WARNING

Asphyxiation Hazard

- Do not use this radiant heater for heating human living quarters.
- Do not use in unventilated areas.
- The flow of combustion and ventilation air must not be obstructed.
- Proper ventilation air must be provided to support the combustion air requirements of the heater being used.
- Refer to the specification section of the Owner's Manual, heater's dataplate, or contact the L.B. White Company to determine combustion air ventilation requirements of the heater.
- Lack of proper ventilation air will lead to improper combustion.
- Improper combustion can lead to carbon monoxide poisoning in humans leading to serious injury or death. Symptoms of carbon monoxide poisoning can include headaches, dizziness and difficulty in breathing.
- Symptoms of improper combustion affecting livestock can be disease, lower feed conversion, or death.

FUEL GAS ODOR

Propane gas and natural gas have man-made odorants added specifically for detection of fuel gas leaks. If a gas leak occurs, you should be able to smell the fuel gas. THAT'S YOUR SIGNAL TO GO INTO IMMEDIATE ACTION!

- Do not take any action that could ignite the fuel gas. Do not operate any electrical switches. Do not pull any power supply or extension cords. Do not light matches or any other source of flame. Do not use your telephone.
- Get everyone out of the building and away from the area immediately.
- Close all propane gas tank or cylinder fuel supply valves, or the main fuel supply valve located at the meter if you use natural gas.
- Propane gas is heavier than air and may settle in low areas. When you have reason to suspect a propane leak, keep out of all low areas.
- Natural gas is lighter than air and can collect around rafters or ceilings.
- Use your neighbor's phone and call your fuel gas supplier and your fire department. Do not re-enter the building or area.
- Stay out of the building and away from the area until declared safe by the firefighters and your fuel gas supplier.
- **FINALLY**, let the fuel gas service person and the firefighters check for escaped gas. Have them air out the building and area before you return. Properly trained service people must repair the leak, check for further leakages, and then relight the heater for you.

ODOR FADING -- NO ODOR DETECTED

- **Some people cannot smell well. Some people cannot smell the odor of the man-made chemical added to propane or natural gas. You must determine if you can smell the odorant in these fuel gases.**
- Learn to recognize the odor of propane gas and natural gas. Local propane gas dealers and your local natural gas supplier (utility) will be more than happy to give you a "scratch and sniff" pamphlet. Use it to become familiar with the fuel gas odor.
- Smoking can decrease your ability to smell. Being around an odor for a period of time can affect your sensitivity to that particular odor. Odors present in animal confinement buildings can mask fuel gas odor.
- **The odorant in propane gas and natural gas is colorless and the intensity of its odor can fade under some circumstances.**
- If there is an underground leak, the movement of gas through the soil can filter the odorant.
- Propane gas odor may differ in intensity at different levels. Since propane gas is heavier than air, there may be more odor at lower levels.
- **Always be sensitive to the slightest gas odor.** If you continue to detect any gas odor, no matter how small, treat it as a serious leak. Immediately go into action as discussed previously.

ATTENTION -- CRITICAL POINTS TO REMEMBER!

- Propane gas and natural gas have a distinctive odor. Learn to recognize these odors. (Reference "Fuel Gas Odor" and "Odor Fading" sections above.)
- If you have not been properly trained in repair and service of propane gas and natural gas fueled heaters, then do not attempt to light the heater, perform service or repairs, or make any adjustments to the heater on a propane gas or natural gas fuel system.
- Even if you are not properly trained in the service and repair of radiant heaters, ALWAYS be consciously aware of the odors of propane gas and natural gas.
- A periodic "sniff test" around the heater or at the heater's joints; i.e. hose, connections, etc., is a good safety practice under any conditions. If you smell even a small amount of gas, CONTACT YOUR FUEL GAS SUPPLIER IMMEDIATELY. DO NOT WAIT!

Safety Precautions

1. Do not attempt to install, repair or service this heater or the gas supply line unless you have continuing expert training and knowledge of gas heaters.

Qualifications for service and installation of this equipment are as follows:

QUALIFICATIONS FOR SERVICING AND INSTALLATION:

- a. To be a qualified gas heater service person, you must have been trained in gas-fired heater servicing, repair and also have sufficient experience to allow you to troubleshoot, replace defective parts, and test heaters in order to get them into a continuing safe and normal operation condition. You must completely familiarize yourself with each model heater by reading and complying with the safety instructions, labels, owner's manual, etc. that is provided with each heater.
 - b. To be a qualified gas installation person, you must have sufficient training and experience to handle all aspects of installing, repairing and altering gas lines, including selecting and installing the proper equipment, and selecting proper pipe size to be used. This must be done in accordance with all local, state and national codes as well as the manufacturer's requirements.
2. All installations or applications of L. B. White Co., Inc.'s radiant heater and associated zone control panel should meet the requirements of local, state and national L.P. gas and natural gas, electrical and safety codes. Your gas supplier, local licensed electrician, local fire department and government agencies can help you determine these requirements. In the absence of local codes, comply with the following:
 - ANSI/NFPA 58, latest edition, Standard for Storage and Handling of Liquefied Petroleum Gas and/or
 - ANSI Z223.1/NFPA 54, National Fuel Gas Code
 - ANSI/NFPA 70, National Electrical Code.
 3. If at any time you notice something unusual about the operation of your heater such as gas odor, overheating, flames other than in the combustion cone area, etc., evacuate the area immediately and call your fire department and your gas service agency. Get assurances from the fire department that the area is free of gas before you attempt to relight the heater.
 4. The components on the heater that call for hand operation should work with hand pressure only. If more force is required, have a qualified gas heater service agency replace the complete part. Do not attempt to repair.

5. This heater is intended for the heating of livestock in agricultural animal confinement buildings only. The heater shall only be mounted inside the animal confinement building. It shall not be used for outside heating applications.
6. Do not locate fuel gas containers or fuel supply hoses anywhere within the heating zone of the heater.
7. Do not block air intakes or discharge outlets of the heater. Doing so may cause improper combustion or damage to the heater components leading to property damage or animal loss.
8. Do not move, handle, or service the heater while in operation or connected to fuel supply.
9. The hose assembly providing fuel to the heater must be inspected on a regular basis. This should be done at least once a year, or when the building is cleaned out. If it is evident there is excessive abrasion or wear, or if the hose is cut, it must be replaced prior to heater being put into operation. The hose assembly shall be protected from animals, building materials, and contact with hot surfaces during use. The hose assembly shall be that specified by the manufacturer. See parts list.
10. Check for gas leaks and proper function upon installation, before building repopulation and when relocating.
11. If the gas flow is interrupted and the burner flame is extinguished, immediately shut off the gas. Do not relight the heater until you are sure that all of the gas that may have accumulated through the heater has cleared away. Do not relight the heater until at least five minutes have passed.
12. If the heater is to be relocated, make sure that all gas connections are capped and the gas supply is shut off. All connection points must be leak checked after disconnection and after reconnection.



WARNING Burn Hazard

- The heater's combustion cones and canopy are extremely hot during operation and shortly after shutting down.
 - Always be aware of your proximity to the heater and avoid contact with its hot surfaces during or shortly after operation.
 - Failure to follow this warning can result in burns leading to severe injury.
13. The grower shall inspect the heater before building repopulation. Such inspection should consist of, but is not limited to, the following points of action:

- Insure proper clearance of heater to nearest combustible materials.
 - Check for general cleanliness. Clean if necessary.
 - Check for tightness of the gas hose connections.
14. A qualified service person shall inspect the heater and its gas train at least on an annual basis. This should consist of, but is not limited to, the following points of action:
- Start-up and shut down of the heaters and zone control panel to test for proper operation.
 - Leak check of all pipe joints and hose connections.
 - Thorough cleaning of the exterior of the heater, its inlet venturi, combustion cones and filter (if applicable).
- Thorough inspection of the heater’s component parts for corrosion, stripped threads, etc. with subsequent parts replacement as necessary.
 - Gas pressure checks.
15. Turn off the gas supply when the heater is not in use.

Installation Instructions

GENERAL

1. Read all safety precautions and follow L. B. White recommendations when installing this heater. If during the installation or relocating of the heater, you suspect that a part is damaged or defective, call a qualified service agency for repair or replacement.
2. Position the heater properly before use in accordance with requirements for combustible clearances, ground clearance, tilt angle, and to protect the brooder from livestock. Refer to Fig. 2 as well as the specification table on page 4 in this manual, for information on installation and clearances.
3. Position the gas hose outside of the hot zone directly above the heater to avoid any contact with the hot canopy surface of the heater. Refer to Fig. 2.
4. Insure that all accessories that ship with the heater have been removed from inside of the heater’s shipping container and installed. This pertains to gas hose, regulators, etc.
5. The heater’s gas regulator (with pressure relief valve) should be installed outside of building. Any regulators inside the buildings must be properly vented to the outside. Local, state and national codes always apply to regulator installation. Natural gas regulators with a vent limiting device may be mounted indoors without venting to outdoors.
6. Any regulator mounted outside the building be protected against the weather, particularly ice formation. Ice formation can lead to overpressurization of the regulator and subsequent gas leaks. See codes covering proper protection.
7. Always use pipe joint compound that is resistant to liquefied petroleum gas and natural gas.
8. Check all connections for gas leaks using approved gas leak detectors. Gas leak testing is performed as follows:

 **WARNING**
Fire and Explosion Hazard

 - Do not use open flame (matches, torches, candles, etc.) in checking for gas leaks.
 - Use only approved leak detectors.
 - Failure to follow this warning can lead to fires or explosions.
 - Fires or explosions can lead to property damage, personal injury or death.

 - Check all pipe connections, hose connections, fittings and adapters upstream of the gas control with approved gas leak detectors.
 - In the event a gas leak is detected, check the components involved for cleanliness and proper application of pipe compound before further tightening.
 - Furthermore tighten the gas connections as necessary to stop the leak.
 - After all connections are checked and any leaks are stopped, turn on the main burner.
 - Stand clear while the main burner ignites to prevent injury caused from hidden leaks that could cause flashback.
 - With the main burner in operation, check all connections, hose connections, fittings and joints as well as the gas control valve inlet and outlet connections with approved gas leak detectors.

- If a leak is detected, check the components involved for cleanliness in the thread areas and proper application of pipe compound before further tightening.
 - Tighten the gas connection as necessary to stop the leak.
 - If necessary, replace the parts or components involved if the leak cannot be stopped.
 - Ensure all gas leaks have been identified and repaired before proceeding.
9. A qualified service agency must check for proper operating gas pressures upon installation of the heaters.
 10. Use the proper gas supply line to assure proper functioning of the heaters. Typically, 3/4 in. ID black iron pipe is used to supply gas to the inlet of the zone control panel with 1/2 in. ID black iron pipe used to convey the gas to the heaters. However, always consult your fuel gas supplier, or the L. B. White Co., Inc. for proper line sizing and installation.
 11. Infraconic heaters require a regulated gas supply to the gas inlet. Exceeding the gas inlet pressure rating can result in poor performance and unreliable operation. Refer to page 4 of this manual for information on gas pressures relating to specific models.
 12. The heater is designed for either L.P. vapor withdrawal or natural gas, depending on model number. Do not use this heater in an LPG liquid withdrawal system. Do not permit LPG in liquid form to enter the heater at any time.
 13. The corrosive atmosphere present in animal confinement buildings can cause component failure or heater malfunction. The heater should be periodically inspected and cleaned in accordance with the Maintenance and Cleaning Instructions in this manual. Make sure that livestock is protected by a back up alarm system that limits high and low temperatures and also activates appropriate alarms.
 14. Take time to understand how to operate and maintain the heater using the owner's manual. Make sure you know how to shut off the gas supply to the building and to the individual heaters. Contact your gas supplier if you have any questions.
 15. Any defects found in performing any of the service procedures must be eliminated and defective parts replaced immediately. Retest the heater before placing it back into service.

ATTENTION

- Model I40 heaters use an integral hanging bracket with key ring for hanging the heater.
- Attach only steel cable or chain to the key ring. Do not use combustible hanging materials such as ropes, lines, etc.
- The installer must make sure that the heater is hung so control end of heater is positioned 1° to 5° down from horizontal after gas supply hose is attached. This allows proper venting of heater and eliminates potential heat damage to optional dust filter.
- Repositioning of factory installed key ring into hanging bracket may be required.
- Refer to following illustrations.

FIG. 2

INSTALLATION LAYOUT FOR SAFE CLEARANCES

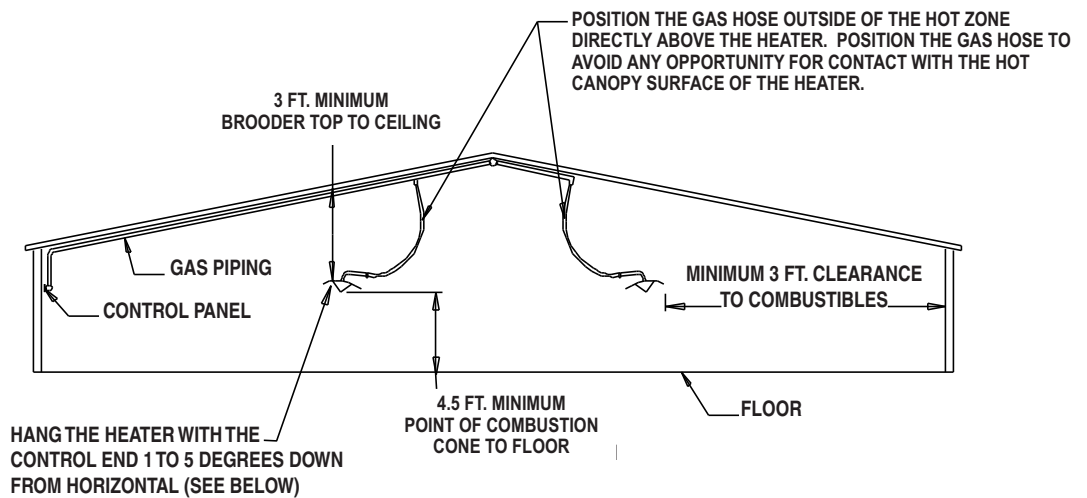

THIS

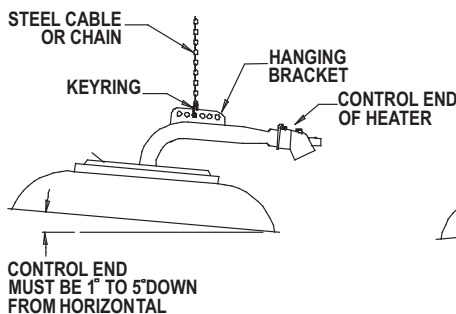

NOT THIS

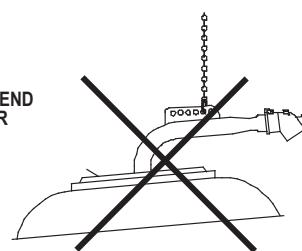

Your heater is supplied with one of the following gas train assemblies. Refer to the appropriate illustrations.

FIG. 3 STANDARD HOSE

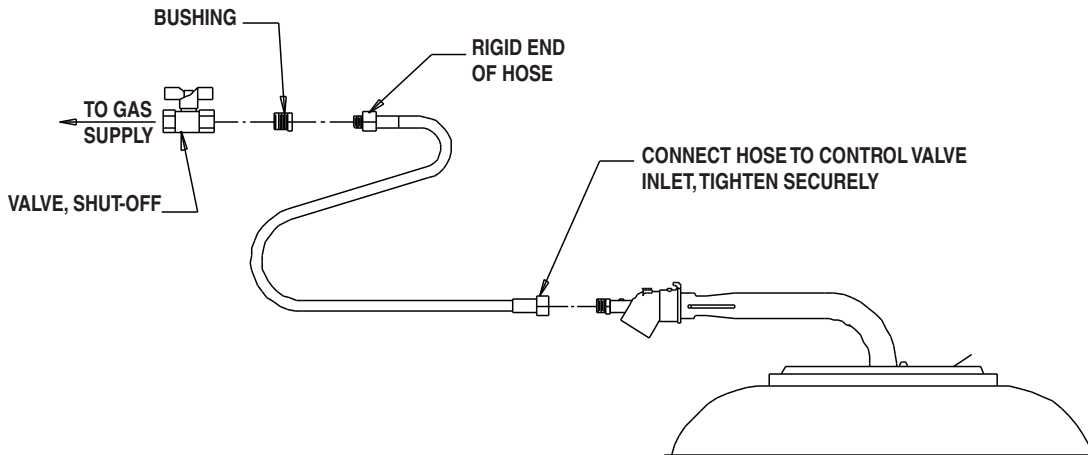
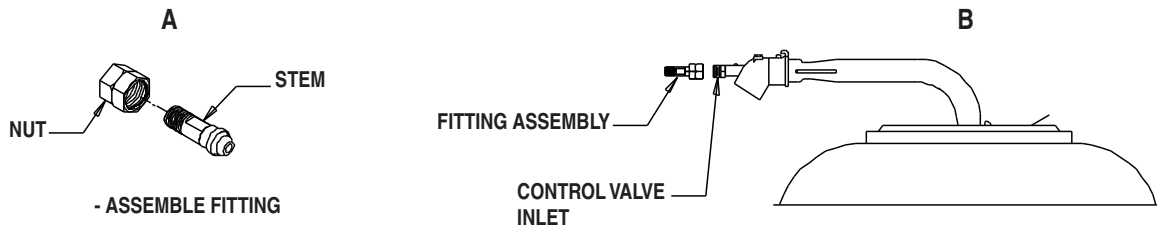
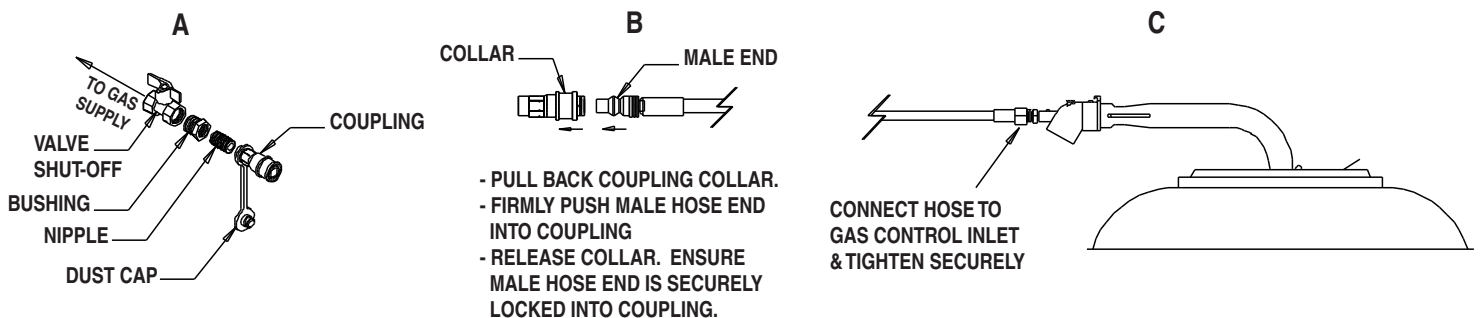

FIG. 4 1/8 NPT FITTING KIT, PART #23406



- ATTACH FITTING TO CONTROL VALVE INLET & TIGHTEN SECURELY.
- CONNECT APPROVED GAS HOSE ASSEMBLY WITH APPROPRIATE CONNECTIONS TO 1/8 NPT FITTING.

FIG. 5 HOSE & QUICK COUPLING KIT



- ASSEMBLE COUPLING KIT COMPONENTS & TIGHTEN SECURELY.
- CONNECT TO GAS SUPPLY.

- PULL BACK COUPLING COLLAR.
- FIRMLY PUSH MALE HOSE END INTO COUPLING
- RELEASE COLLAR. ENSURE MALE HOSE END IS SECURELY LOCKED INTO COUPLING.

ZONE CONTROL PANEL COMPONENT FUNCTION AND INSTALLATION

The zone control panel is a remote mounted control system allowing the operation of a specific amount of heaters within a certain zone of the building.

These panels will control the following quantity of heaters depending on fuel type.

Modulating System			
Model and Heat Output	Fuel	Medium Capacity Panel	High Capacity Panel
		Quantity	Quantity
I40 (40,000 BTUH)	L. P. Gas	7	20
	Natural Gas	4	

The zone control panel must be mounted to a flat, stable wall inside the building. Use lag screws provided. For the modulating zone panels, care must be taken to ensure that the thermostatic control module is not exposed to outside air temperatures. Exposure of the thermostatic control module to outside air temperatures (Example: when sidewall curtains are open) may cause the heater to provide unwanted heat.

There are a number of optional configuration zone control panels available. These include high and medium capacity, modulating thermostatically controlled for stand alone, non-electrical operation, as well as solenoid controlled for incorporation into the building's environmental control system. Consult your local L. B. White dealer or distributor or call the L. B. White Co. for recommendations on the best configuration of zone panels for your specific application.

The zone control panel must have an adjustable high pressure regulator installed upstream of the inlet of the zone control panel. This regulator may be purchased from the L. B. White Co. as an optional accessory. For L.P. gas, the regulator must be capable of handling a maximum inlet pressure of 10 psi, while supplying an outlet pressure of 5 psi nominal. This pressure is supplied to the zone control or individual controlled heater. For natural gas, a regulator must be installed to supply an outlet pressure of 5 psi nominal.

INSTALLING DUST FILTER

(Optional accessory on some heater models)

IMPORTANT

This filter kit is designed to provide additional dust filtration capability and capacity for Infraconic heaters when installed in severely dusty environments.

1. Attach filter adapter to injector body. The injector body tabs fit into the slots on the adapter. Rotate the adapter to lock it onto the injector body.
2. Position the filter onto the adapter. Ensure all adapter holes are covered by the filter.
3. Securely attach the filter to the adapter using the beaded cable tie.
4. Ensure filter does not sag or touch heater's canopy.

FIG. 6

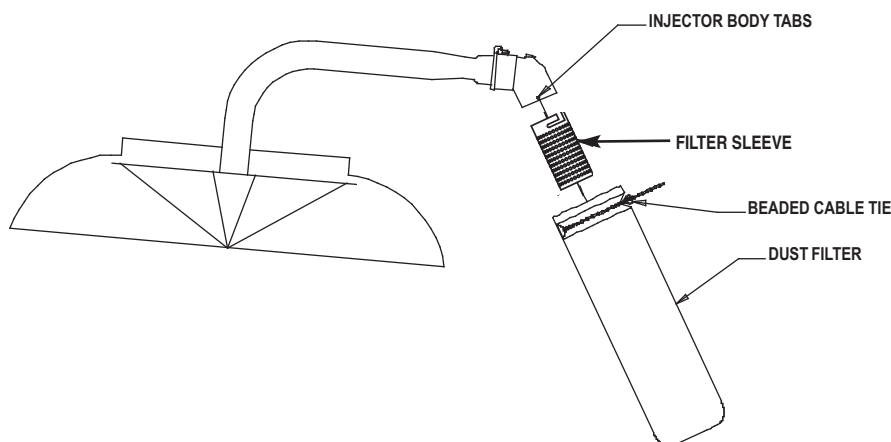

Start-Up Instructions



WARNING Fire or Explosion Hazard

- Do not force the safety gas control valve button.
- Use only your hand to depress the gas control button. Never use any tools.
- If the button will not depress by normal hand pressure, the control should be replaced by a qualified service person.
- Force or attempted repair may result in fire or explosion, causing property damage, severe injury, or death.

Follow these start-up instruction steps for initial start-up before building repopulation. For normal start-up, simply turn the thermostatic head above room temperature.

1. Open all gas supply valves to the heater(s) and check for gas leaks at all connections using approved lead detectors.
2. Adjust the thermostatic head, located on either the zone control panel, or for individually controlled heaters, directly on the heater, to its maximum temperature setting. See Fig. 7.

FIG. 7

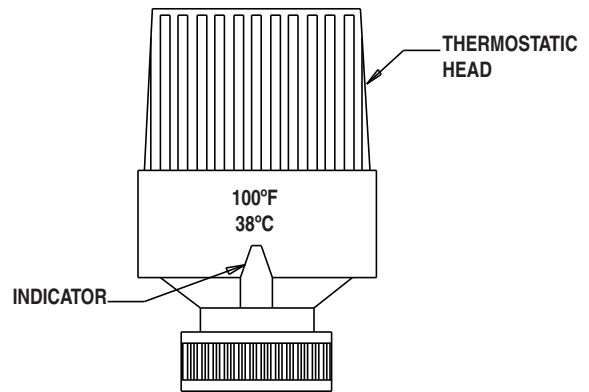

3. Fully depress the button on the safety control valve while applying flame to the inner cone point. Keep the button fully depressed for about 30 seconds until the inner cone stays lit. Allow outer combustion cone to heat up completely.
4. Adjust the temperature by decreasing the setpoint on the thermostatic head to the desired temperature. The heater will cycle from low heat to high heat based upon thermostatic head set point.

FIG. 8

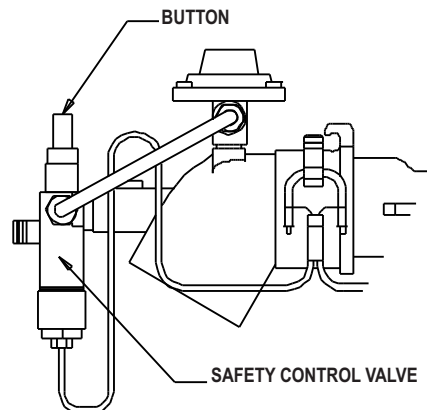

Shut-Down Instructions

To reduce temperature, simply turn down the thermostatic control on the zone panel or on the individual heater.

To shut down the heaters for maintenance, cleaning or service:

1. Shut off all gas supply valves to the heaters.

2. Allow heaters to burn off fuel gas remaining in the gas supply line.
3. Turn down the thermostatic head to minimum setting.

Cleaning Instructions

CAUTION

- Disinfectants utilized in agricultural animal confinement buildings may contain chemicals damaging to components of the heater.
- Protect the safety gas control valve and pressure valve by wrapping these components with a plastic bag before disinfecting.
- Always make sure to remove the plastic bag or other protective covering before start up.

It is important to clean the heater on a regular basis to maintain proper combustion and to eliminate future problems.

The frequency of cleaning will vary depending upon livestock being raised and overall ventilation of the building.

Problems associated with lack of cleaning typically are:

- Black soot on inside of canopy.
- Gas backflashing in venturi tube or injector body.
- Burner flame appearing beyond outer cone.

A. HEATER

CLEANING WITH BACKPACK BLOWERS AND HEATER BLOWER

Blower Part No. 21170

For general cleaning when the heaters do not have heavy accumulations of dust or dirt, use either a backpack type of blower or the heater blower.

Follow the same procedures for cleaning as listed for Cleaning with Compressed Air.

If the dust and dirt cannot be removed effectively using the backpack blower or heater blower, then clean the heater using either the Compressed Air or Water Cleaning methods.

CLEANING WITH COMPRESSED AIR

1. Turn off the gas supply to the heater and let the heater cool.
2. Direct the air at the combustion cones, working your way around entire surface of cone assembly.
3. Blow air through air inlet opening in the venturi tube to blow back out any loosened dust through combustion cones.
4. Repeat Steps 2 and 3 until the cones and the venturi tube are no longer emitting dust.
5. Inspect the cones and venturi tube to make sure these areas are clean.

6. Return the heater to its normal hanging position and relight the heater.

FIG. 9

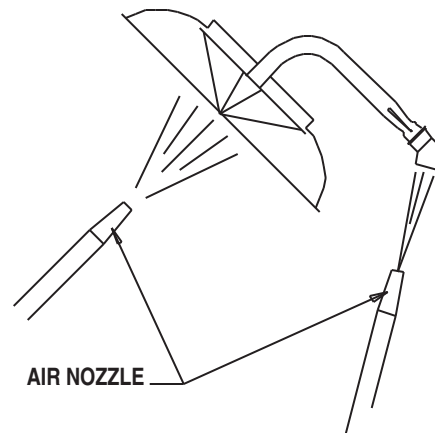

CLEANING WITH WATER (Continued on page 13)

The following should be accomplished only if the heater cannot be cleaned adequately by the compressed air method. **DO NOT USE HIGH PRESSURE WASHERS!**

1. Wrap the pressure switch and safety control valve with a plastic bag to protect these components from entry of water.
2. Using a standard garden hose with standard faucet pressure, spray water against the cones to wash out the build up of dust in the cones and the venturi tube. Work your way around the entire cone assembly. See Fig. 10.

FIG. 10

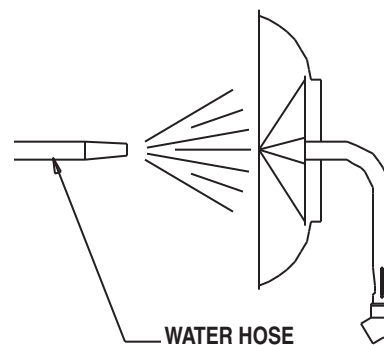

3. Position the heater as shown in Fig. 11 and run water down through the venturi tube and out through combustion cones.

FIG. 11

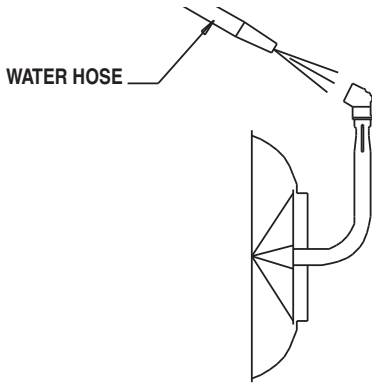

4. Repeat steps 2 and 3 until water runs clean.
5. Remove the plastic bag. Inspect the cones and venturi tube to make sure these areas are clean.
6. Return the heater to its original hanging position.
7. Shake the heater vigorously to clear water off of the combustion cones to allow proper ignition of gas at the inner cone.

8. Relight the heater to dry out the cones and the venturi tube.

B. FILTER

A. During continued use:

- Remove filter and shake off dust.
- Do not squeeze or tap filter while filter is installed on heater. Doing so will cause dust to be blown into venturi tube or combustion cones.

B. After continued use or before building repopulation:

- Remove filter and shake it.
- Use compressed air or standard water faucet pressure to clean it.
- Do not use high pressure water, air, or a washing machine. Filter material damage may occur.
- If water is used, squeeze out excess water from filter before installation.
- Let filter dry before lighting heater.

Maintenance Instructions

1. Have your gas supplier check all gas piping annually for leaks or restrictions in gas lines. Also, at this time have your gas supplier clean out the sediment trap on the zone control panel of any debris that may have accumulated.
 2. **The heater's surrounding area shall be kept clear and free from combustible materials, gasoline, and other flammable vapors and liquids.**
 3. Regulators can wear out and function improperly. Have your gas supplier check the date codes on all regulators installed and check delivery pressures to the appliance to make sure that the regulator is suitable for continued use.
 4. Regulators must be periodically inspected to make sure the regulator vents are not blocked. Debris, insects, insect nests, snow, or ice on a regulator can block vents and cause excess pressure at the appliance.
 5. For safety as well as for optimum performance at the heater, it is necessary to keep the inside and the outside of the heater free of dust, dirt or any combustible material. If any operational component shows signs of rust or corrosion, replace the component immediately.
 6. If any warning or instruction labels, dataplates, etc. become lost or hard to read, replace them immediately. Do not operate the heater until you have all instructions and can read and understand them.
 7. Check overall condition of heater for cracked or damaged components, loose screws or bolts, etc. Replace any suspect components.
 8. Check all hose and tubing assemblies for cracks, abrasions or ruptures. Replace any hoses that are suspect.
- If it becomes apparent that a dark spot has formed part way up on the inner combustion cone or a build up of debris is occurring in the bottom of the inner cone, it will be necessary to clean out the combustion cone assembly. Refer to "Cleaning Instructions".

Service Instructions

GENERAL



WARNING Burn Hazard

- Heater surfaces are extremely hot for a period of time after the heater has been shut down.
- Allow the heater to cool before performing service, maintenance, or cleaning.
- Failure to follow this warning will result in burns causing injury.



WARNING Fire and Explosion Hazard

- Do not disassemble or attempt to repair any heater components or gas train components.
- All component parts must be replaced if defects are found.
- Failure to follow this warning will result in fire or explosions, causing property damage, injury, or death.

1. Close the fuel supply valve to the heater before servicing unless it is necessary to have it open for your service procedure.
2. For reassembly, reverse the respective service procedure. Ensure gas connections are tightened securely.
3. After servicing, start the heater to ensure proper operation and check for gas leaks.
4. **Clean the heater's orifices with compressed air or a soft, dry rag. Do not use files, drills, broaches, etc. to clean the orifice holes. Doing so will enlarge the hole, causing combustion or ignition problems. Replace the orifice if it cannot be cleaned properly.**

SAFETY GAS CONTROL VALVE

1. Disconnect the gas hose.
2. Loosen the gas supply tube compression nut and swing the tube away from the safety control valve.
3. Remove the thermocouple from the safety control valve.
4. Loosen the screw on the injector body.
5. Remove the safety gas control valve with injector tube from the heater.
6. Remove the injector tube.

FIG. 12

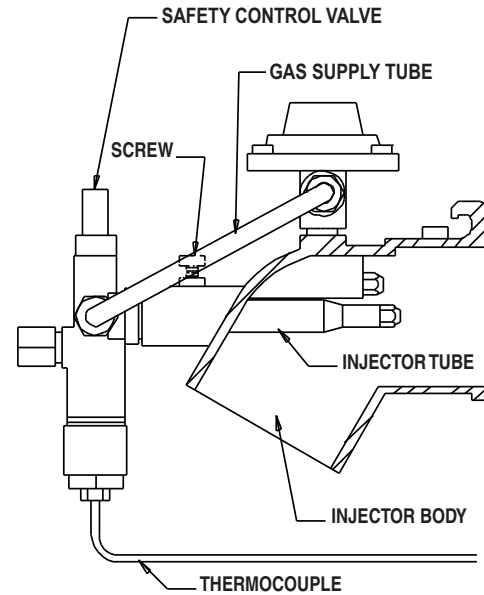

BYPASS ORIFICE Individual Control Heaters

The bypass orifice is located in the valve body of the individual controlled heaters. Its purpose is to supply low pressure gas to the inner combustion cone when heat demand is satisfied.

The orifice may become plugged with dirt after significant heater use. Symptoms of a plugged orifice are:

- Inner cone goes out when thermostatic head cycles heater back to low heat.
- Flame back flashing through air intake at injector body.

Refer to the following instructions:

1. Apply wrenches to the flats of the valve body and the adapter nut. See Fig. 13.
2. Loosen the adapter nut at the outlet of the valve body.
3. Pull the control assembly with adapter and adapter nut from the valve body. See Fig. 13.
4. Using a 3/16 in. nut driver, remove the orifice from valve body. See Fig. 14. Clean or replace if necessary. At reinstallation, do not overtighten as thread damage may occur.

FIG. 13

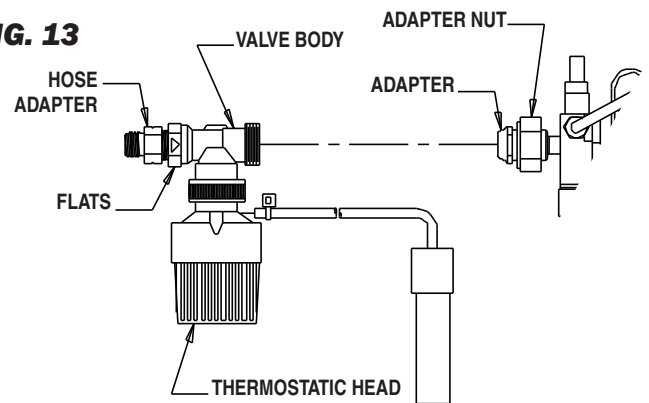
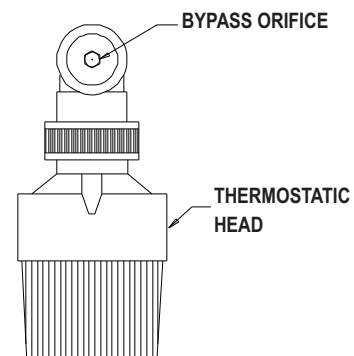

FIG. 14



THERMOSTATIC HEAD

Individual Control Heaters & Modulating Zone Panels

- The following service instructions are the same on individual control or zone control heaters.
- The head assembly includes the adjustable thermostatic head, capillary and sensor. The part numbers for the thermostatic heads are:
 - Zone panel head: Part No. - 09416 w/ 26 ft. capillary
 - Individual control head: Part No. - 09415 w/ 6 ½ ft. capillary

The head assembly would need to be replaced if damage occurred because of:

- Careless handling during installation, cleaning or servicing.
- Locating the sensor and capillary too close to floor or ground level, allowing contact with livestock.

The symptom of component failure would be the heater not operating from high heat to low heat after the thermostatic head is adjusted to a low temperature requirement. If this occurs, refer to the following instructions:

1. Loosen the attachment knob located at the thermostatic head and valve body and discard head. See Fig. 15.
2. Securely tighten the knob of the replacement head to the valve body, otherwise temperature sensing will be affected.

FIG. 15

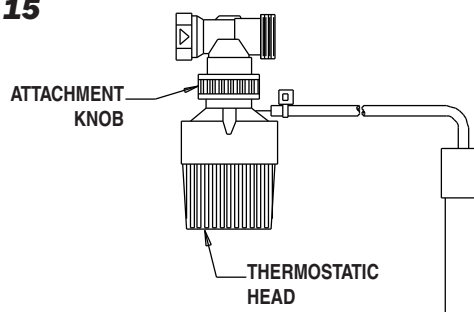

BURNER ORIFICES

- This heater has two orifices.
- Remove only one orifice at a time for cleaning. Reinstall the orifice before proceeding to clean the other orifice.
- If orifices are reversed combustion characteristics of the heater will change on low fire.

1. Remove the thermocouple from gas control valve and screw from injector body.
2. Pull the injector body from the venturi tube to allow access to primary and secondary orifices.

3. Using a 6 mm hex nut driver, remove an orifice and clean if necessary. When reinstalling, do not overtighten as thread damage may occur.

FIG. 17

INJECTOR BODY VIEWED FROM ORIFICE END

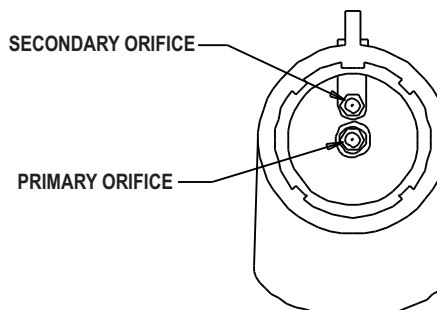
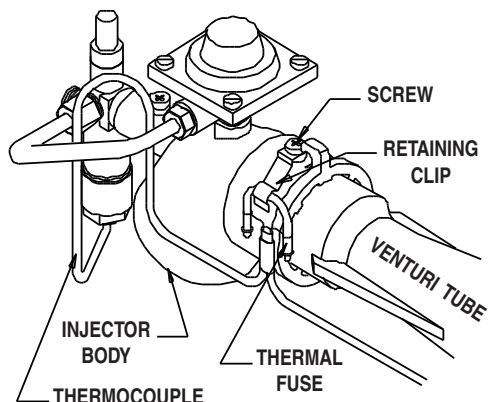

FIG. 16



MAIN BURNER PRESSURE VALVE

A. Removal

1. Loosen gas supply tube compression nuts and remove gas tube. See Fig. 18.
2. Remove pressure valve from injector body by firmly grasping the pressure switch and turning it counter clockwise.

- The replacement pressure valve will ship with a small tube of Loctite thread lock.
- Apply Loctite sparingly (normally 2 drops is sufficient) to the upper threads of the adapter. See Fig. 19.
- Thread the pressure valve into the injector body. The bottom of the valve should contact the injector body, and the gas inlet of the valve is perpendicular to the injector body.

FIG. 18

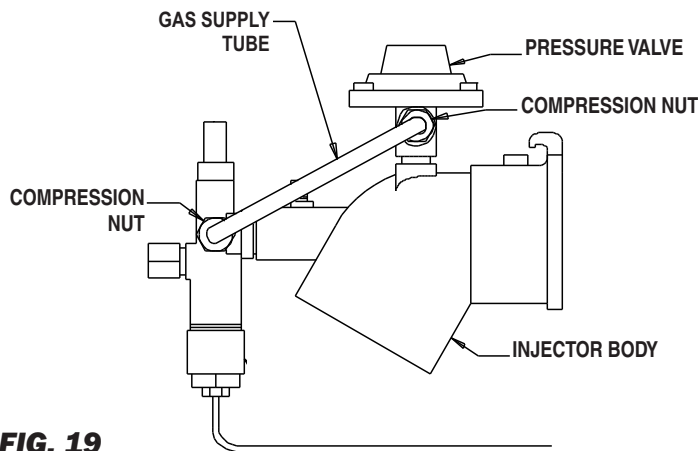
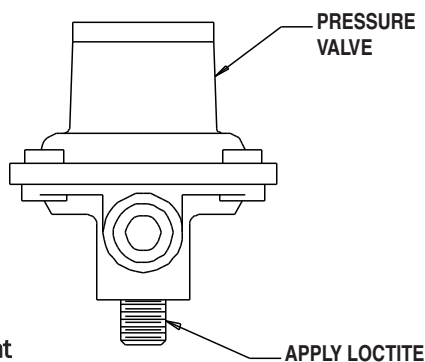

FIG. 19



B. Adjustment

The pressure valve is responsible for delivering gas to the secondary orifice and in turn to the combustion cones.

Under normal operation, heaters within a specific zone will modulate the heat output through a gas pressure range of 10 in. W.C. to 5 psig. To accomplish this full range of heat modulation, gas pressure is constantly supplied to the primary burner orifice and to the secondary orifice via the pressure valve. The pressure valve is factory-set to open at

50-54 in. W.C. (approx. 2 psig) pressure. When the thermostatic head opens on a call for heat gas pressure

between 2 and 5 psig gas is delivered to the combustion cones through both the primary and secondary orifices for full heat output.

Although rarely needed, the pressure valve may require adjustment after significant operation time if it is observed the pressure valve of a heater opens at a slower or faster rate than other heaters within a zone. The opening point of the pressure valve is indicated by observing the inner combustion cone flame color and size. As the pressure valve opens, the flame at the inner cone changes from a light blue flame to a larger red/orange flame. This procedure may require the assistance of another person.

INITIAL PREPARATION

- Close fuel supply to zone panel.
- Clean heater thoroughly.
- Connect an accurate 0-100 in. W.C. pressure gauge to zone panel.
- Remove spring from zone panel regulator. Replace it with spring that allows pressure adjustment range to 65 in. W.C. (Available from L.B. White, Part # 21876)
- Open fuel supply to zone panel and light heaters.
- Adjust thermostatic head back to minimum setting.

PROCEDURE

It is suggested to perform this procedure in a low light condition. Slowly increase gas pressure at zone panel regulator to 52 in. W.C., observing the opening point of the pressure valve. If the pressure valve opens at any pressure other than 52 in. W.C., perform the following:

- Remove pressure valve cap.
- Turn the valve's adjusting screw all the way in (clockwise).
- Set zone panel pressure to 52 in. W.C.
- Slowly turn the pressure valve screw out (counterclockwise) until the pressure valve opens.

COMPLETION

- Replace pressure valve cap.
- Adjust thermostat on zone panel to highest setting.
- Remove test spring from regulator on zone panel and replace with original spring.
- Adjust thermostatic head to minimum temperature.
- Set zone panel regulator to 10-12 in. W.C.
- Set thermostatic head to desired temperature.

THERMOCOUPLE

1. Remove the thermocouple at the pilot gas control valve. See Fig. 20.
2. Loosen the thermalfuse retaining clip screw. See Fig. 20.
3. Loosen upper retaining nut on thermocouple. See Fig. 21.
4. Remove the thermocouple, with nuts and cover, from the heater assembly.
5. Transfer nuts and cover to replacement thermocouple. Position as shown in Fig. 22.
6. Position the thermalfuse under the retaining clip and tighten the screw.
7. Install the thermocouple. Angle the thermocouple tip to allow passage through the keyhole slot and into the thermocouple location hole of the burner plate. Pull up on the thermocouple lead so the lower nut is tight against the inside of the heater housing. Tighten upper nut against the housing. See Fig. 23.
8. The installed finished position of the thermocouple is $1/2 - 9/16$ inch from the top edge of thermocouple to the heater housing. See Fig. 23.
9. Thread the nut on thermocouple into gas control valve. Tighten finger tight and snug in place. DO NOT OVERTIGHTEN.

FIG. 21

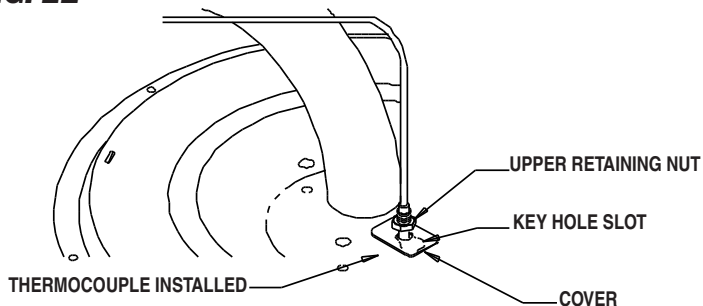

FIG. 22

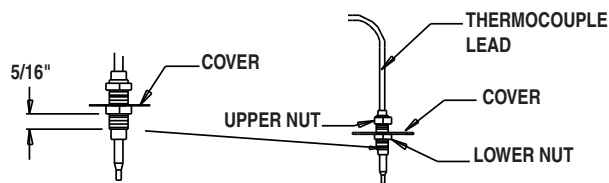

FIG. 23

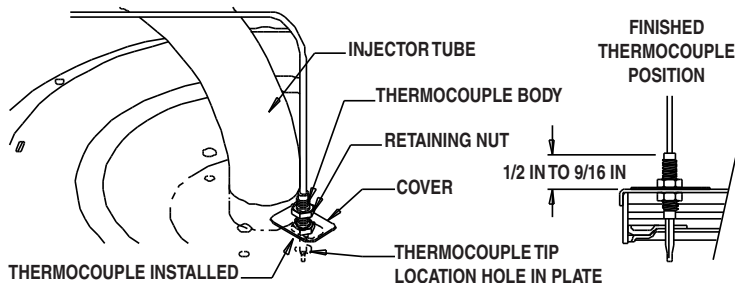
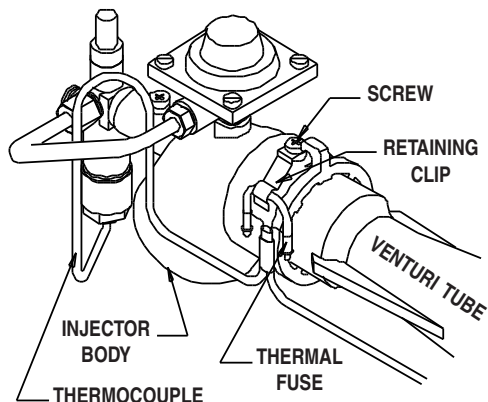

FIG. 20



A. Preparation

1. Obtain an L.B. White pressure gauge test kit - Part No. 20736.
2. Close the fuel supply valve to the heater.
3. Brush or blow off any dust and dirt on or in the vicinity of the gas control valve.
4. Disconnect the gas hose from the heater.

B. Gauge Installation

1. Connect the pressure test kit between the heater and its gas supply hose as shown in Fig. 24. Insure both gas shut-off valves on the test kit are in the closed position when connecting the kit to the heater and gas supply.
2. Open the fuel supply valve to the heater.
3. Open only the gas shut-off on the test kit to which the gas supply hose is connected.
4. Adjust the thermostatic head to its maximum setting and light the heater.

C. Reading Pressures

1. With the heater operating at full heat output and at minimum heat, the pressure gauge should read the pressure specified on the dataplate of the zone panel.
2. Does the reading on the gauge of the test kit agree with that specified on the dataplate? If so, then no further checking or adjustment is required. Proceed to Section D.
3. If the pressure does not agree with that specified on the dataplate, then the regulator controlling gas pressure to the heater requires adjustment.

D. Completion

1. Once gas pressure has been confirmed and/or properly set, close the fuel supply valve to the heater and allow the heater to burn off any gas remaining in the gas supply hose.
2. Remove the gauge kit and reconnect the heater's gas hose to the heater.
3. Reconnect the heater to its electrical supply.
4. Open the main fuel supply valves to the heater. Light the heater.
5. Set thermostatic head to desired temperature.

FIG. 24

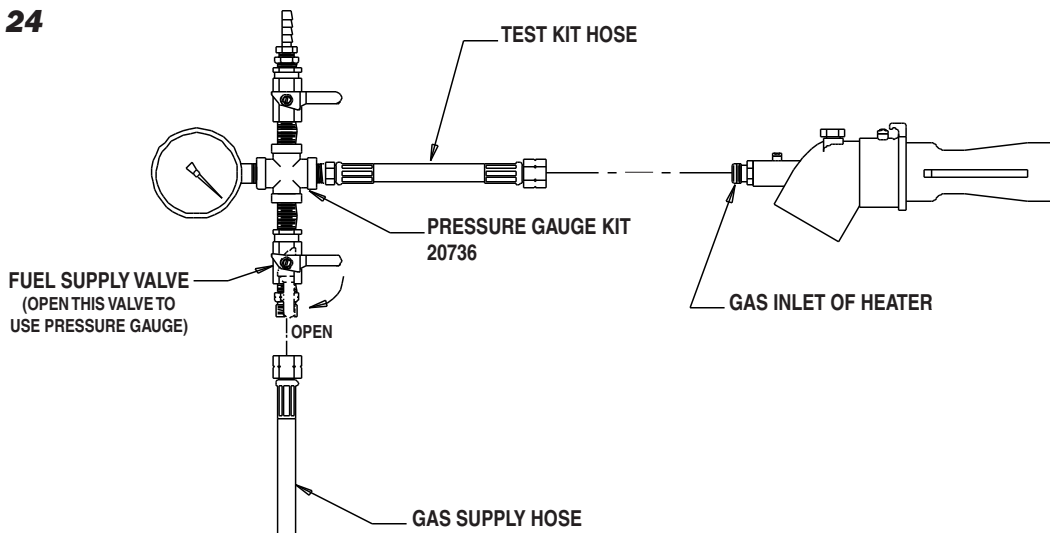

Troubleshooting Guide

READ THIS ENTIRE SECTION BEFORE BEGINNING TO TROUBLESHOOT PROBLEMS.

The following troubleshooting flow charts provide systematic procedures for isolating heater problems. The charts are intended for use by a QUALIFIED GAS HEATER SERVICE PERSON. **DO NOT SERVICE THE HEATER UNLESS YOU HAVE BEEN PROPERLY TRAINED.**

TEST EQUIPMENT REQUIRED

The following pieces of test equipment will be required to troubleshoot this system with minimal time and effort.

- **Digital Multimeter** - For measuring DC voltage when using thermocouple diagnostic kit.
- **Thermocouple Diagnostic Kit** - (Part No. 21188) When used with a standard digital multimeter, this kit allows testing of the thermocouple and electromagnetic power unit.
- **Pressure Gauge** - (L. B. White Part No. 20736) For checking inlet pressures to the heaters.

INITIAL PREPARATION

- Inspect heater for damage.
- Clean heater as necessary.

 **WARNING**
Burn Hazard

- Troubleshooting this system may require operating the heater with the burner on. Use extreme caution when working on the heater.
- Failure to follow this warning will result in burns causing severe injury.

Heater Problems

Page

1. Inner Combustion Cone will not Light	21
2. Inner Combustion Cone Lights, but will not Stay Lit	22
3. Outer Combustion Cone Does Not Heat up on High Thermostatic Head Setting	23
4. Heater Backflashes Gas Through Injector Body Air Inlet	24
5. Heater Does Not Return to Low Heat	24

Components should be replaced only after each step has been completed and replacement is suggested in the flow chart. Refer to the servicing sections as necessary to obtain information on disassembly and replacement procedures of the component once the problem is identified by the flow chart.

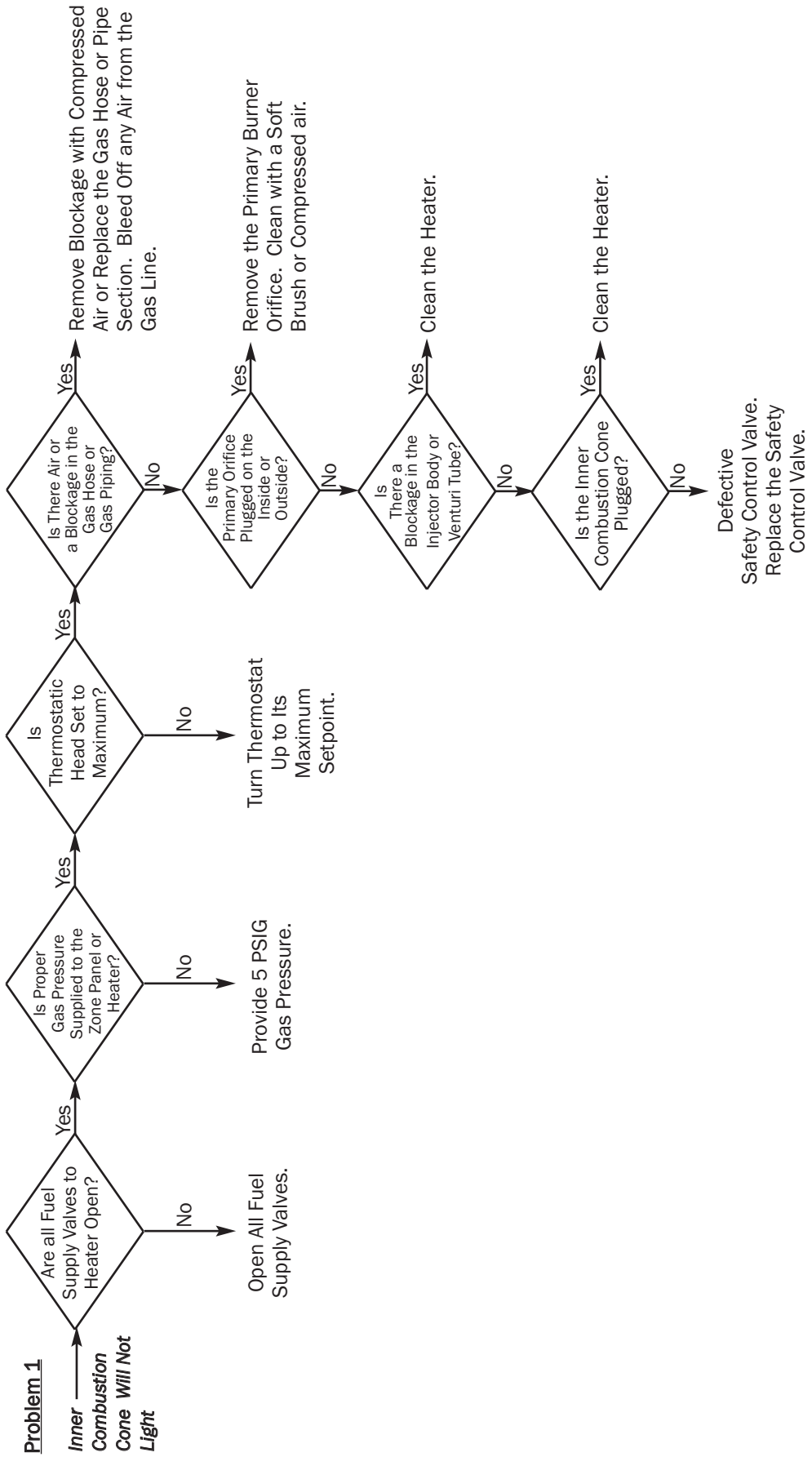

Problem 2

Inner Combustion Cone Lights, but will not Stay Lit

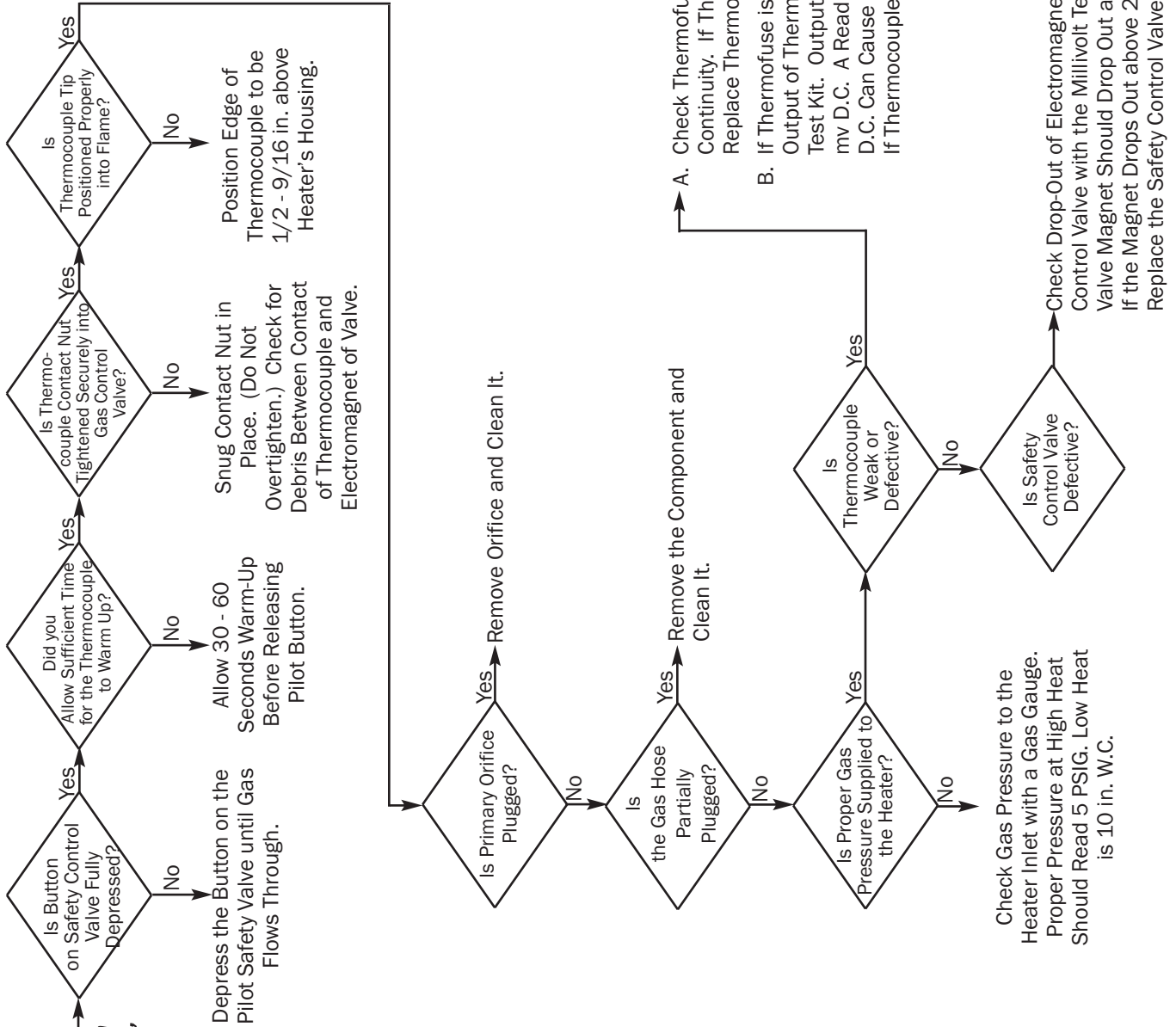

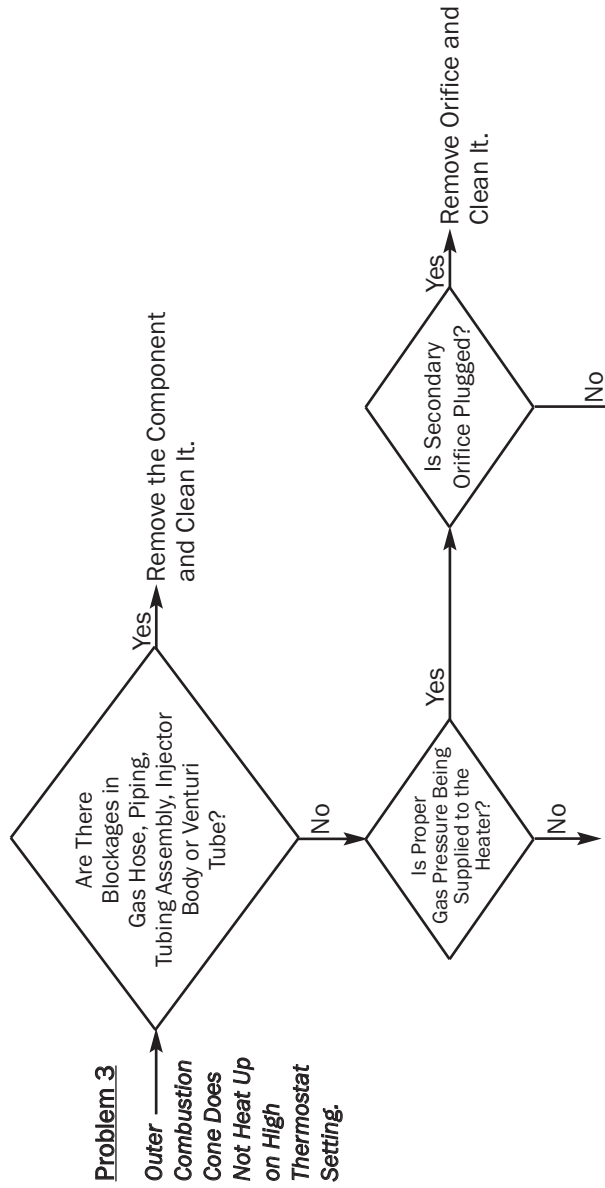

A. Remove Thermostatic Head from Thermostatic Valve Body. If Outer Cone Lights, Replace Thermostatic Head and Sensor Assembly.

-- OR --

B. If Outer Combustion Cone still does not Light, Adjust Pressure Valve According to Instructions in Owner's Manual.

-- OR --

C. Replace Thermostatic Head Valve Body.

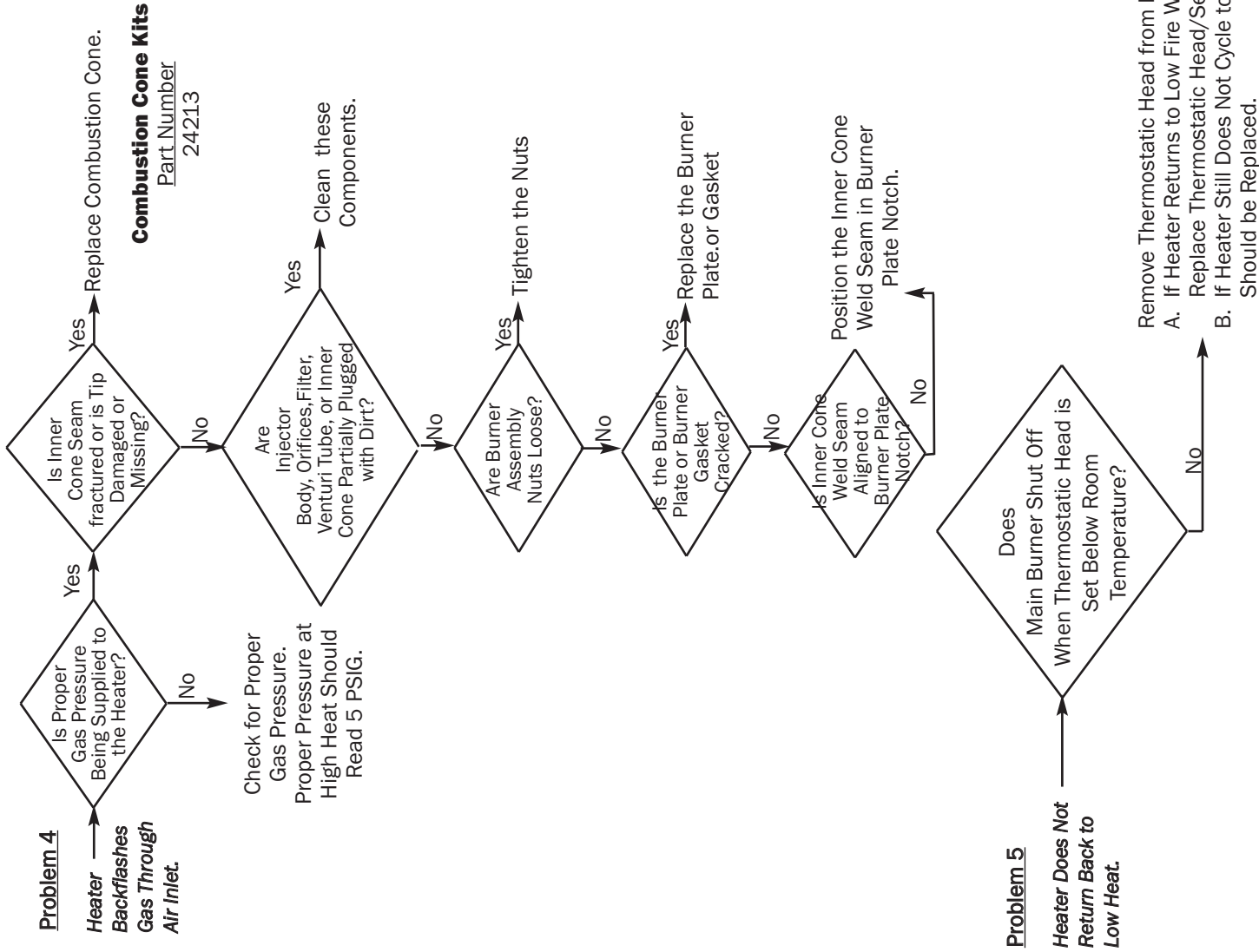

Heater Component Function

Burner Orifices

Metering devices used to feed gas to combustion cones at a specific flow rate.

Canopy

Reflective aluminum heat shield for heater.

Double Combustion Chamber

Made of special alloy steel. This is where combustion of gas occurs, providing radiant heat used in the warming process.

Gas Hose

Flexible connector used to convey gas from gas supply line to inlet of heater.

Injector Body

Secures pilot gas valve to injector tube. Also allows combustion air to be drawn in to injector tube with gas flow for combustion.

Venturi Tube

Tubular steel “neck” connecting the gas control valve and burner orifices to the combustion cones. Gas is fed to the combustion cones through the injector tube.

Manual Shut Off Valve

It's purpose is to shut off gas flow to the heater if maintenance or service are required, or if an emergency situation occurs. When the handle on the manual valve is turned parallel to gas flow, the valve is completely open delivering full gas supply to the appliance. Turning handle perpendicular (90°) to gas flow shuts off gas flow.

Safety Control Valve

Safety shut off device used to feed fuel gas to the heater combustion cones for heating. Will shut off flow of gas completely if gas flame is extinguished.

Pressure Valve

Feeds higher pressure gas to burner orifice, and therefore to combustion cones.

Thermal Fuse

Safety device connected in series with thermocouple which will shut off gas control valve if temperature of heater injector body increases abnormally. (Available only with thermocouple for replacement purposes.)

Thermocouple

Safety device that will continue to hold open electromagnet in safety gas control valve when heat is applied to thermocouple tip. It will also stop gas flow if inner combustion flame is out.

Thermostatic Head and Sensor Assembly

Device used to cycle the heater and to maintain a specific temperature. Used on modulating zone panels and individual control heaters only.

Parts Identification

PARTS SCHEMATIC

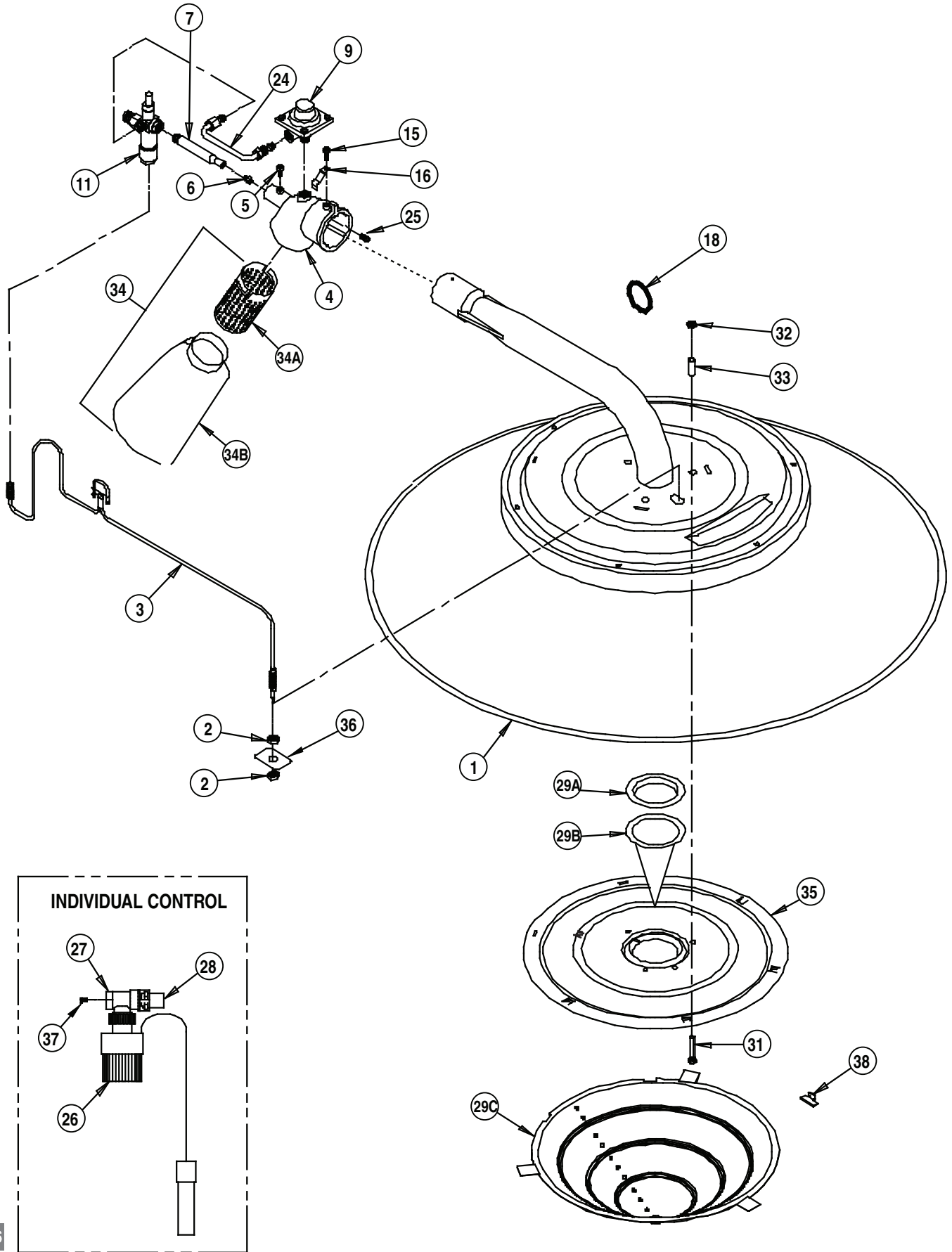

PARTS LIST

Item	Description	Part No.	
1	Venturi Tube and Burner Assembly	23261	
2	Thermocouple Retaining Nut	09576	
3	Thermocouple with Fusible Link	09596	
4	Injector Casting with Air Register Plate	Propane Gas Natural Gas	23337 09778.
5	Retaining Screw for Injector Tube	09572	
6	Primary Burner Orifice (Low Heat)	Propane Gas Natural Gas	26706 26704
7	Injector Tube	09562	
9	Pressure Valve	09861	
11	Safety Control Valve	Zone Control Heaters Individual Control Heaters	22285 22286
15	Retaining Screw for Control Assembly and Thermocouple	09575	
16	Thermocouple Fuse Clip	09565	
18	Keyring	09620	
24	Tubing, Pilot Safety Valve to Pressure Valve	09569	
25	Secondary Orifice (High Heat)	Propane Gas Natural Gas	26705 26703
26	Thermostatic Head with Sensor, Individual Control	09415	
27	Valve, Modulating	Propane Gas Natural Gas	09748 09749
28	Sleeve, Adapter	09682	
29	Kit, Combustion Cones and Gasket Consisting of:	24214	
29A	Gasket	09560	
29B	Inner Cone	09557	
29C	Outer Cone	24543	
31	Screw, 10-32 x 1 1/2	23636	
32	Nut, 10-32	09578	
33	Spacer	09568	
34	Filter Kit	20428	
34A	Filter Sleeve	20421	
34B	Filter	23953	
35	Burner Plate	23201-01	
36	Cover Plate, Thermocouple	23315	
37	Orifice, Bypass (Individual Control)	Propane Gas Natural Gas	09744 09745
38	Truss Clip	24486	

OPTIONS (Not Illustrated):

Item	Description	Part No.
Coupling, Quick Disconnect, Kit		21335
	Consisting Of:	
	Shut-Off Valve	05548
	Nipple, 1/4 in. Close	01142
	Coupling, Quick Disconnect	21328
	Bushing, 1/2 x 1/4	01519
Hoses	1/4 in. x 6 ft., Rigid x Swivel, Poultry	20495
	1/4 in. x 10 ft., Rigid x Swivel, Poultry	20496
	1/4 in. x 12 ft., Rigid x Swivel, Poultry	20497
	1/4 in. x 6 ft., Swivel Both Ends, Swine	20499
	1/4 in. x 10 ft., Swivel Both Ends, Swine	20242
	1/4 in. x 15 ft., Swivel Both Ends, Swine	20500
Kit, 1/8 NPT Fitting (Not Illustrated)		20406

Warranty Policy

EQUIPMENT

L.B. White Co., Inc. warrants that the component parts of its equipment are free from defects in material and workmanship, when properly installed, operated, and maintained in accordance with the Installation and Maintenance Instructions, safety guides and labels contained with each unit. If, **within 12 months from the date of purchase by the end user**, any component is found to be defective, L.B. White Co., Inc. will at its option, repair or replace the defective part or equipment, with a new part or equipment, F.O.B., Onalaska, Wisconsin.

A warranty card on file at L.B. White will automatically qualify a unit and its component parts for warranty consideration. If a warranty card is not on file, a copy of the bill of sale will be required to establish warranty qualification. If neither is available, the warranty period will be 12 months from date of shipment from L. B. White.

PARTS

L.B. White Co., Inc. warrants that replacement parts purchased from the company and used on the appropriate L. B. White equipment are free from defects both in material and workmanship for **12 months from the date of purchase by the end user**. Warranty is automatic if a component is found defective within 12 months of the date code marked on the part. If the defect occurs more than 12 months later than the date code but within 12 months from the date of purchase by the end user, a copy of a bill of sale will be required to establish warranty qualification.

duration to the duration of the applicable warranty stated above. The remedies set forth above are the sole and exclusive remedies available hereunder. L.B. White will not be liable for any incidental or consequential damages directly or indirectly related to the sale, handling or use of the equipment, and in any event L.B. White's liability in connection with the equipment, including for claims based on negligence or strict liability, is limited to the purchase price.

The warranty set forth above is the exclusive warranty provided by L.B. White, and all other warranties, including any implied warranties or merchantability or fitness for a particular purpose, are expressly disclaimed. In the event any implied warranty is not hereby effectively disclaimed due to operation of law, such implied warranty is limited in

Some regions do not allow limitations on how long an implied warranty lasts, so the above limitation may not apply to you. Some regions do not allow the exclusion or limitation of incidental or consequential damages, so the above limitation or exclusion may not apply to you. This warranty gives you specific legal rights, and you may also have other rights which vary from state to state.

Replacement Parts and Service

Contact your local L.B. White dealer for replacement parts and service or call the L.B. White Company, Inc. at (800) 345-7200 for assistance. Be sure that you have your heater model number when calling.