

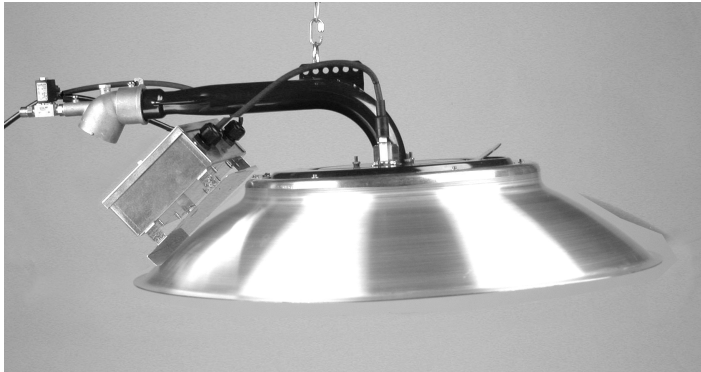

# Owner's Manual and Instructions

Spark Ignition Infraconic  
Agricultural Building Radiant Heaters



MODELS	OUTPUT (Btuh)	FUEL
I34	34,200	Propane Vapor Withdrawal or Natural Gas



## Congratulations!

**You have purchased the finest radiant heater available for the heating of livestock in agricultural animal confinement buildings.**

Your new L.B. White radiant heater incorporates the benefits from the most experienced manufacturer of heating products using state-of-the-art technology.

We, at L.B. White, **thank you** for your confidence in our products and welcome any suggestions or comments you may have...call us toll free at 1-800-345-7200.

### ATTENTION ALL USERS

This heater has been tested and evaluated by L.B. White Co., Inc. as a direct gas-fired radiant heater with intended use for the heating of livestock in agricultural animal confinement buildings. If you are considering using this product for any application other than its intended use, then please contact your fuel gas supplier, or the L.B. White Co., Inc.



Quality heaters you can count on.

W6636 L.B. White Rd., Onalaska, WI 54650 ■ (800) 345-7200 ■ (608) 783-5691 ■ (608) 783-6115, fax ■ [info@lbwhite.com](mailto:info@lbwhite.com)



 **GENERAL HAZARD WARNING**

- Failure to comply with the precautions and instructions provided with this heater, can result in:
  - Death
  - Serious bodily injury or burns
  - Property damage or loss from fire or explosion
  - Asphyxiation due to lack of adequate air supply or carbon monoxide poisoning
  - Electrical shock
- Read this Owner's Manual before installing or using this heater.
- Only properly-trained service people should repair or install this heater.
- Save this Owner's Manual for future use and reference.
- Owner's Manuals and replacement labels are available at no charge. For assistance, contact L.B. White at 1-800-345-7200.

 **WARNING**

- Proper gas supply pressure must be provided to the inlet of the heater.
- Refer to rating plate for proper gas supply pressure.
- Gas pressure in excess of the maximum inlet pressure specified at the heater inlet can cause fires or explosions.
- Fires or explosions can lead to serious injury, death, building damage or loss of livestock.
- Gas pressure below the minimum inlet pressure specified at the heater inlet may cause improper combustion.
- Improper combustion can lead to asphyxiation or carbon monoxide poisoning and therefore serious injury or death to humans and livestock.

 **WARNING**

**Fire and Explosion Hazard**

- Not for home or recreational vehicle use.
- Installation of this heater in a home or recreational vehicle may result in a fire or explosion.
- Fire or explosions can cause property damage or loss of life.

**FOR YOUR SAFETY**

Do not store or use gasoline or other flammable vapors and liquids in the vicinity of this or any other heater.

**FOR YOUR SAFETY**

- If you smell gas:
1. Open windows.
  2. Don't touch electrical switches.
  3. Extinguish any open flame.
  4. Immediately call your gas supplier.

 **WARNING**

**Fire and Explosion Hazard**

- Keep solid combustibles a safe distance away from the heater.
- Solid combustibles include wood or paper products, feathers, straw, and dust.
- Do not use the heater in spaces which contain or may contain volatile or airborne combustibles.
- Volatile or airborne combustibles include gasoline, solvents, paint thinner, dust particles or unknown chemicals.
- Failure to follow these instructions may result in a fire or explosion.
- Fire or explosions can lead to property damage, personal injury or loss of life.



## Table of Contents

---

<b>SECTION</b>	<b>PAGE</b>
General Information .....	3
Heater Specifications .....	4
Safety Precautions .....	5
Installation Instructions	
General .....	7
Gas Train Assembly .....	9
Zone Control Panel Function and Installation .....	10
Installing Dust Filter .....	10
Start-Up Instructions .....	11
Shut-Down Instructions .....	11
Cleaning Instructions	
A. Heater .....	12
B. Filter .....	12
Maintenance Instructions .....	13
Service Instructions	
General .....	13
On/Off Switch .....	14
Ignition Module .....	14
Burner Orifice .....	14
High Voltage Ignition Lead .....	15
Igniter .....	15
High Limit Switch .....	16
Gas Control Valve .....	17
Gas Pressure Checks .....	17
Troubleshooting Guide .....	18
Electrical Connection and Ladder Diagram .....	21
Heater Component Function .....	22
Parts Identification	
Parts Schematic .....	23
Parts List .....	24
Warranty Policy .....	25
Replacement Parts and Service .....	25

---

## General Information

This owner's manual includes all options and accessories commonly used on or with this heater. However, depending on the configuration purchased, some options and accessories may not be included.

When calling for technical service assistance, or for other specific information, always have the model number and serial number available.

This manual will instruct you in the operation and care of your radiant heater. Have your qualified installer review this manual with you so that you fully understand the heater and how it functions.

The gas supply line installation, and the repair, installation and servicing of the heater requires continuing expert training and knowledge of gas heaters and should not be attempted by anyone who is not so qualified. See page 6 for definition of the necessary qualifications.

Contact your local L. B. White distributor or the L. B. White Co., Inc. for assistance, or if you have any questions about the use of the heater or its application.

The L. B. White Co., Inc. has a policy of continuous product improvement. It reserves the right to change specifications and design without notice.

# Radiant Heater Specifications

<b>SPECIFICATIONS</b>		<b>Model</b>	
		<b>I34</b>	
Maximum Input (Btuh)			34,200
Ventilation Air to Support Combustion			400 CFM
Inlet Gas Supply Pressure at the Heater	<b>FULL OUTPUT (On/Off Version)</b>	<b>MAX.</b>	5 psig
		<b>MIN.</b>	5 psig
	<b>ZONE CONTROLLED (Dual Solenoid Version)</b>	<b>MAX.</b>	5 psig
		<b>MIN.</b>	2.0 psig
Burner Manifold Pressure at Maximum Pressure			5 psig
Heater Dimensions (See Fig. 1)	<b>"A"</b>		26-3/8 in.
	<b>"B"</b>		20 1/4 in.
	<b>"C"</b>		10 3/8 in.
Net Weight			15 lbs. 8 oz.
Fuel Consumption Per Hour	<b>PROPANE GAS</b>		1.58 lbs./hr.
	<b>NATURAL GAS</b>		34.2 CFH
Electrical Supply (Volts/HZ/Phase)			120/60/1
Amp Draw			0.5
Animal Coverage Per Heater (1)	<b>CHICKENS</b>		2500 - 3800
	<b>TURKEYS</b>		800 - 950
	<b>SWINE</b>		300
Recommended Height Installation For Livestock From Point of Combustion Cone to Floor	<b>CHICKENS</b>		6 - 7 ft.
	<b>TURKEYS</b>		4.5 ft.
	<b>SWINE</b>		4 - 5 ft.
Minimum Safe Clearances to Combustible Materials	<b>TOP OF HOOD TO CEILING</b>		3 ft.
	<b>POINT OF COMBUSTION CONE TO FLOOR</b>		4.5 ft.
	<b>SIDES</b>		3 ft.
Animal Occupied Zone Temperature Control Sensor Location (2)	<b>POULTRY</b>	<b>VERTICAL FROM FLOOR</b>	6-12 in.
		<b>HORIZONTAL FROM BROODER</b>	8-12 ft.
	<b>SWINE</b>	<b>VERTICAL FROM FLOOR</b>	Above Animal Height
		<b>HORIZONTAL FROM BROODER</b>	4-8 ft.

- (1) There are other factors that will affect the quantity of animals each heater can cover. These include building ventilation and control systems, building insulation, building size and population density, etc. Consult your L. B. White dealer or call L. B. White for specific recommendations for your application.
- (2) This is typical sensor placement range. The size and type of livestock being grown, heater spacing and height, etc. will dictate sensor location. Care should always be taken to ensure that the sensor is sufficiently high as to not be damaged by the animal during operation.

**FIG. 1**

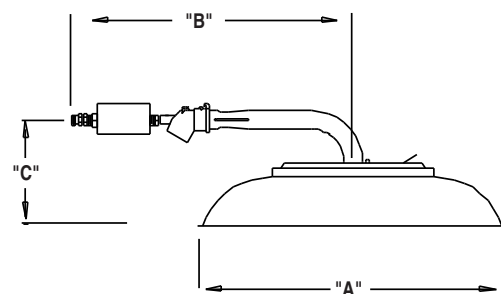

# Safety Precautions



## **WARNING** **Asphyxiation Hazard**

- Do not use this radiant heater for heating human living quarters.
- Do not use in unventilated areas.
- The flow of combustion and ventilation air must not be obstructed.
- Proper ventilation air must be provided to support the combustion air requirements of the heater being used.
- Refer to the specification section of the Owner's Manual, heater's dataplate, or contact the L.B. White Company to determine combustion air ventilation requirements of the heater.
- Lack of proper ventilation air will lead to improper combustion.
- Improper combustion can lead to carbon monoxide poisoning in humans leading to serious injury or death. Symptoms of carbon monoxide poisoning can include headaches, dizziness and difficulty in breathing.
- Symptoms of improper combustion affecting livestock can be disease, lower feed conversion, or death.

## **FUEL GAS ODOR**

Propane gas and natural gas have man-made odorants added specifically for detection of fuel gas leaks. If a gas leak occurs, you should be able to smell the fuel gas. THAT'S YOUR SIGNAL TO GO INTO IMMEDIATE ACTION!

- Do not take any action that could ignite the fuel gas. Do not operate any electrical switches. Do not pull any power supply or extension cords. Do not light matches or any other source of flame. Do not use your telephone.
- Get everyone out of the building and away from the area immediately.
- Close all propane gas tank or cylinder fuel supply valves, or the main fuel supply valve located at the meter if you use natural gas.
- Propane gas is heavier than air and may settle in low areas. When you have reason to suspect a propane leak, keep out of all low areas.
- Natural gas is lighter than air and can collect around rafters or ceilings.
- Use your neighbor's phone and call your fuel gas supplier and your fire department. Do not re-enter the building or area.
- Stay out of the building and away from the area until declared safe by the firefighters and your fuel gas supplier.
- **FINALLY**, let the fuel gas service person and the firefighters check for escaped gas. Have them air out the building and area before you return. Properly trained service people must repair the leak, check for further leakages, and then relight the heater for you.

## **ODOR FADING -- NO ODOR DETECTED**

- Some people cannot smell well. Some people cannot smell the odor of the man-made chemical added to propane or natural gas. You must determine if you can smell the odorant in these fuel gases.
- Learn to recognize the odor of propane gas and natural gas. Local propane gas dealers and your local natural gas supplier (utility) will be more than happy to give you a "scratch and sniff" pamphlet. Use it to become familiar with the fuel gas odor.
- Smoking can decrease your ability to smell. Being around an odor for a period of time can affect your sensitivity to that particular odor. Odors present in animal confinement buildings can mask fuel gas odor.
- The odorant in propane gas and natural gas is colorless and the intensity of its odor can fade under some circumstances.
- If there is an underground leak, the movement of gas through the soil can filter the odorant.
- Propane gas odor may differ in intensity at different levels. Since propane gas is heavier than air, there may be more odor at lower levels.
- **Always be sensitive to the slightest gas odor.** If you continue to detect any gas odor, no matter how small, treat it as a serious leak. Immediately go into action as discussed previously.

## **ATTENTION -- CRITICAL POINTS TO REMEMBER!**

- Propane gas and natural gas have a distinctive odor. Learn to recognize these odors. (Reference "Fuel Gas Odor" and "Odor Fading" sections above.)
- If you have not been properly trained in repair and service of propane gas and natural gas fueled heaters, then do not attempt to light the heater, perform service or repairs, or make any adjustments to the heater on a propane (LP) gas or natural gas fuel system.
- Even if you are not properly trained in the service and repair of radiant heaters, ALWAYS be consciously aware of the odors of propane gas and natural gas.
- A periodic "sniff test" around the heater or at the heater's joints; i.e. hose, connections, etc., is a good safety practice under any conditions. If you smell even a small amount of gas, CONTACT YOUR FUEL GAS SUPPLIER IMMEDIATELY. DO NOT WAIT!

# Safety Precautions

1. Do not attempt to install, repair or service this heater or the gas supply line unless you have continuing expert training and knowledge of gas heaters.

Qualifications for service and installation of this equipment are as follows:

## QUALIFICATIONS FOR SERVICING AND INSTALLATION:

- a. To be a qualified gas heater service person, you must have been trained in gas-fired heater servicing, repair and also have sufficient experience to allow you to troubleshoot, replace defective parts, and test heaters in order to get them into a continuing safe and normal operation condition. You must completely familiarize yourself with each model heater by reading and complying with the safety instructions, labels, owner's manual, etc. that is provided with each heater.
  - b. To be a qualified gas installation person, you must have sufficient training and experience to handle all aspects of installing, repairing and altering gas lines, including selecting and installing the proper equipment, and selecting proper pipe size to be used. This must be done in accordance with all local, state and national codes as well as the manufacturer's requirements.
2. All installations or applications of L. B. White Co., Inc.'s radiant heater and associated zone control panel should meet the requirements of local, state and national L.P. gas and natural gas, electrical and safety codes. Your gas supplier, local licensed electrician, local fire department and government agencies can help you determine these requirements. In the absence of local codes, comply with the following:
    - ANSI/NFPA 58, latest edition, Standard for Storage and Handling of Liquefied Petroleum Gas and/or
    - ANSI Z223.1/NFPA 54, National Fuel Gas Code
    - ANSI/NFPA 70, National Electrical Code.
  3. If at any time you notice something unusual about the operation of your heater such as gas odor, overheating, flames other than in the combustion cone area, etc., evacuate the area immediately and call your fire department and your gas service agency. Get assurances from the fire department that the area is free of gas before you attempt to relight the heater.
  4. The components on the heater that call for hand operation should work with hand pressure only. If more force is required, have a qualified gas heater service agency replace the complete part. Do not attempt to repair.

5. This heater is intended for the heating of livestock in agricultural animal confinement buildings only. The heater shall only be mounted inside the animal confinement building. It shall not be used for outside heating applications.
6. Do not locate fuel gas containers or fuel supply hoses anywhere within the heating zone of the heater.
7. Do not block the air intake, burner venturi tube or burner cone area. Doing so may cause improper combustion or damage to the heater components, leading to property damage or animal loss.
8. Do not move, handle, or service the heater while in operation or connected to fuel supply.
9. The hose assembly must be inspected on a regular basis. This should be done at least once a year, or when the building is cleaned out. If it is evident there is excessive abrasion or wear, or if the hose is cut, it must be replaced prior to heater being put into operation. The hose assembly shall be protected from animals, building materials, and contact with hot surfaces during use. The hose assembly shall be that specified by the manufacturer. See parts list.
10. Check for gas leaks and proper function upon installation, before building repopulation and when relocating.
11. If the gas flow is interrupted and the burner flame is extinguished, immediately shut off the gas. Do not relight the heater until you are sure that all of the gas that may have accumulated through the heater has cleared away. Do not relight the heater until at least five minutes have passed.
12. If the heater is to be relocated, make sure that all gas connections are capped and the gas supply is shut off. All connection points must be leak checked after disconnection and after reconnection.

### **WARNING** Burn Hazard

- The heater's combustion cones and canopy are extremely hot during operation and shortly after shutting down.
  - Always be aware of your proximity to the heater and avoid contact with its hot surfaces during or shortly after operation.
  - Failure to follow this warning can result in burns leading to severe personal injury.
13. The grower shall inspect the heater before building repopulation. Such inspection should consist of, but is not limited to, the following points of action:

- Insure proper clearance of heater to nearest combustible materials.
  - Check for general cleanliness. Clean if necessary.
  - Check for tightness of the gas hose connections.
14. A qualified service person shall inspect the heater and its gas train at least on an annual basis. This should consist of, but is not limited to, the following points of action:
- Start-up and shut down of the heaters and zone control panel to test for proper operation.
  - Leak check of all pipe joints and hose connections.
  - Thorough cleaning of the exterior of the heater, its inlet venturi, combustion cones and filter (if applicable).
  - Thorough inspection of the heater's component parts for corrosion, stripped threads, etc. with subsequent parts replacement as necessary.
  - Gas pressure checks.
15. Turn off the gas supply when the heater is not in use.

---

## Installation Instructions

### GENERAL

1. Read all safety precautions and follow L. B. White recommendations when installing this heater. If during the installation or relocating of the heater, you suspect that a part is damaged or defective, call a qualified service agency for repair or replacement.
2. On initial installation and before use, position the heater properly regarding clearance to combustible materials and ground clearance to protect the heater from livestock. Refer to the specification table on page 4 as well as Figure 2 for installation information for proper hanging and clearances.
3. The heater may be connected to an approved electrical supply and operated from off to full heat output by utilizing the building's environment controller. In this type of installation, 5 psig must be plumbed directly to each radiant heater for proper combustion.
4. For installations requiring two stage heating, a zone control panel is available which, when interfaced with the building's environment controller, will provide from half to full heat output. Refer to page 10 of this manual for more information relative to the control panel.
5. Position the gas hose outside of the hot zone directly above the heater. Position the gas hose to avoid any opportunity for contact with the hot canopy surface of the heater. Refer to Fig. 2.
6. Insure that all accessories that ship with the heater have been removed from inside of heater's shipping container and installed. This pertains to gas hose, regulators, etc.
7. The heater's gas regulator (with pressure relief valve) should be installed outside of building. Typically any regulators inside the buildings must be properly vented to the outside. However, local, state and national codes always apply to regulator installation.
8. Any regulator mounted outside the building be protected against the weather, particularly ice formation. Ice formation can lead to overpressurization of the regulator and subsequent gas leaks. See codes covering proper protection.
9. Always use pipe joint compound that is resistant to liquefied petroleum gas and natural gas.
10. Check all connections for gas leaks using approved gas leak detectors. Gas leak testing is performed as follows:
 

**⚠ WARNING**  
**Fire and Explosion Hazard**

  - Do not use open flame (matches, torches, candles, etc.) in checking for gas leaks.
  - Use only approved leak detectors.
  - Failure to follow this warning can lead to fires or explosions.
  - Fires or explosions can lead to property damage, injury or death.

  - Check all pipe connections, hose connections, fittings and adapters upstream of the gas control with approved gas leak detectors.
  - In the event a gas leak is detected, check the components involved for cleanliness and proper application of pipe compound before further tightening.
  - Furthermore tighten the gas connections as necessary to stop the leak.
  - After all connections are checked and any leaks are stopped, turn on the main burner.
  - Stand clear while the main burner ignites to prevent injury caused from hidden leaks that could cause flashback.

- With the main burner in operation, check all connections, hose connections, fittings and joints as well as the gas control valve inlet and outlet connections with approved gas leak detectors.
  - If a leak is detected, check the components involved for cleanliness in the thread areas and proper application of pipe compound before further tightening.
  - Tighten the gas connection as necessary to stop the leak.
  - If necessary, replace the parts or components involved if the leak cannot be stopped.
  - Ensure all gas leaks have been identified and repaired before proceeding.
11. A qualified service agency must check for proper operating gas pressures upon installation of the heaters.
  12. It is extremely important to use the proper gas supply line to assure proper functioning of the heaters. Typically, 1/2 in. ID black iron pipe is used to convey the gas to the heaters. However, always consult your fuel gas supplier, or the L. B. White Co., Inc. for proper line sizing and installation.
  13. Infraconic heaters require a regulated gas supply to the gas inlet. Exceeding the gas inlet pressure rating can result in poor performance and unreliable operation. Refer to page 4 of this manual for information on gas pressures relating to specific models.
  14. The heater is designed for either L.P. vapor withdrawal or natural gas, depending on model number. Do not use this heater in an LPG liquid withdrawal system. Do not permit LPG in liquid form to enter the heater at any time.
  15. The corrosive atmosphere present in animal confinement buildings can cause component failure or heater malfunction. The heater should be periodically inspected and cleaned in accordance with the Maintenance and Cleaning Instructions in this manual. Make sure that livestock is protected by a back up alarm system that limits high and low temperatures and also activates appropriate alarms.
  16. Take time to understand how to operate and maintain the heater using the owner's manual. Make sure you know how to shut off the gas supply to the building and to the individual heaters. Contact your gas supplier if you have any questions.
  17. Any defects found in performing any of the service procedures must be eliminated and defective parts replaced immediately. Retest the heater before placing it back into service.

**ATTENTION**

**FIG. 2**

**INSTALLATION LAYOUT G FOR SAFE CLEARANCES**

- Model I34 heaters use an integral hanging bracket with key ring for hanging the heater.
- Attach only steel cable or chain to the key ring. Do not use combustible hanging materials such as ropes, lines, etc.
- The installer must make sure that the heater is hung so control end of heater is positioned 1° to 5° down from horizontal after gas supply hose is attached. This allows proper venting of heater and eliminates potential heat damage to optional dust filter.
- Repositioning of factory installed key ring into hanging bracket may be required.
- Refer to following illustrations.

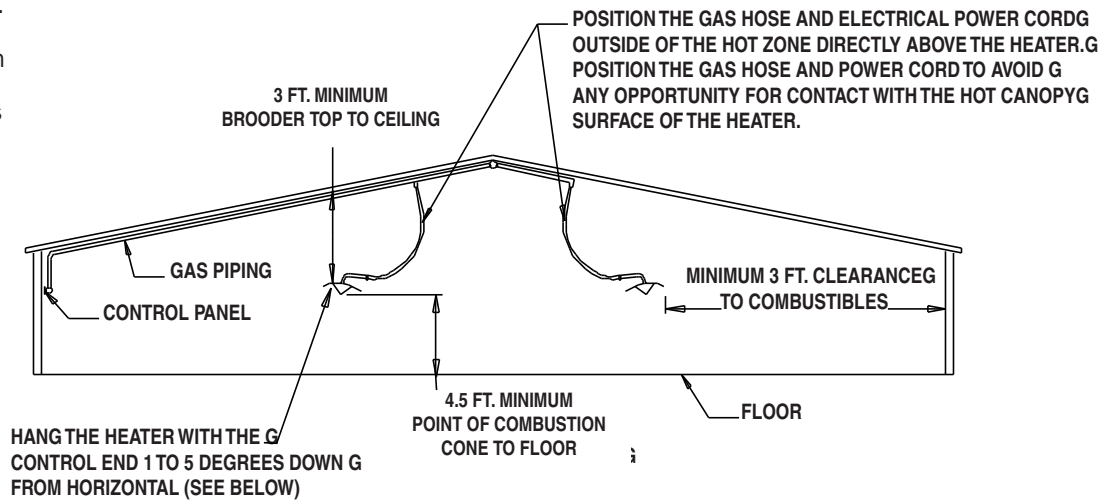

HANG THE HEATER WITH THE CONTROL END 1 TO 5 DEGREES DOWN FROM HORIZONTAL (SEE BELOW)

**THIS**

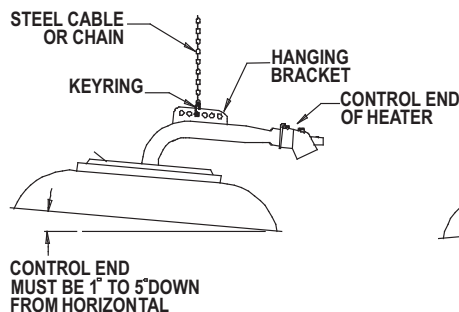

**NOT THIS**

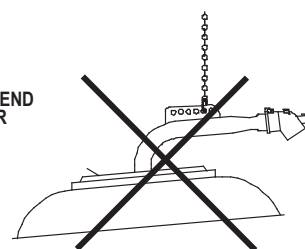

# GAS TRAIN ASSEMBLY

This heater is supplied with one of the following gas train assemblies. Refer to the appropriate illustrations.

**FIG. 3** STANDARD HOSE

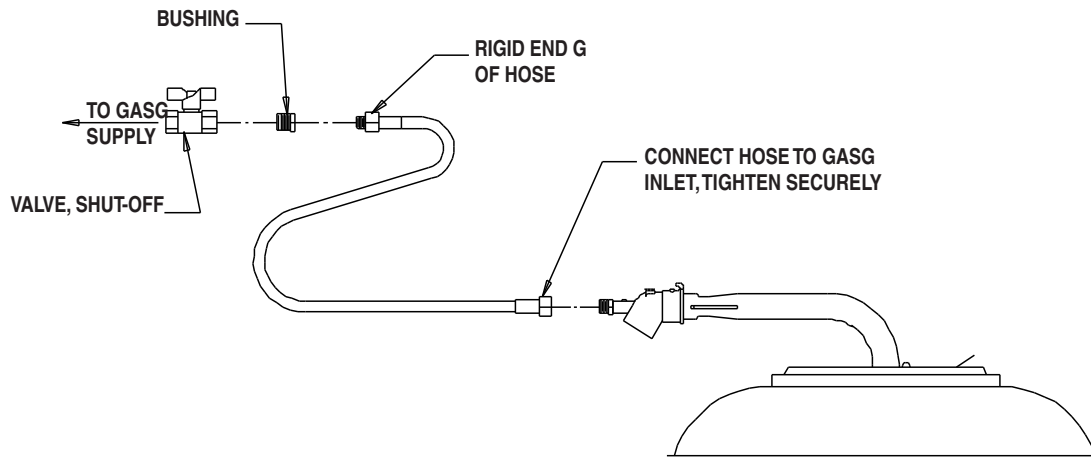

**FIG. 4** 1/8 NPT FITTING KIT, PART #23406

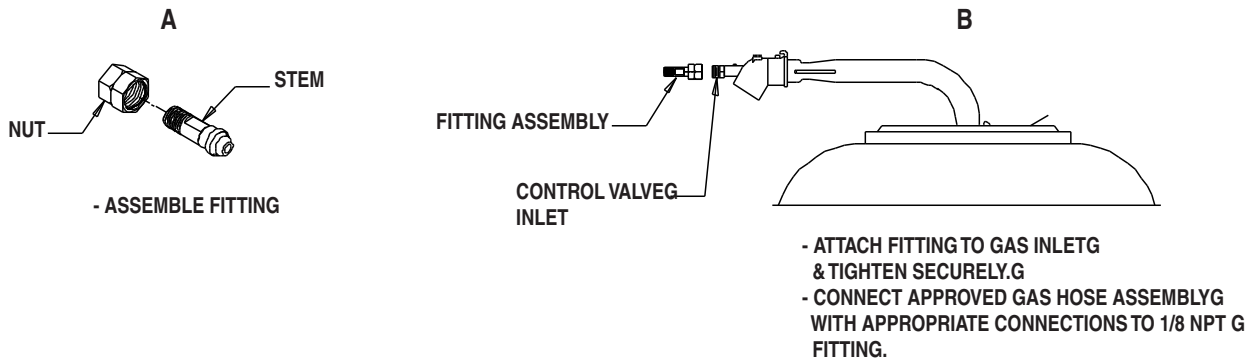

**FIG. 5** HOSE & QUICK COUPLING KIT

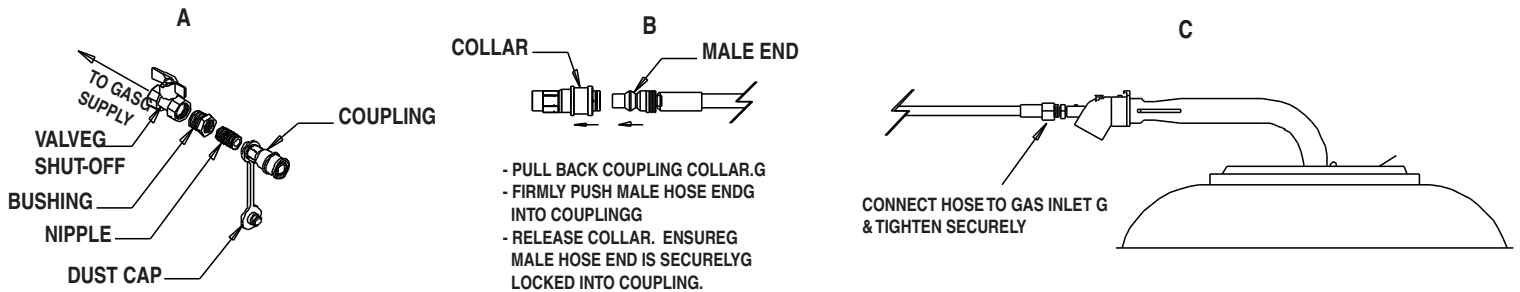

- ASSEMBLE COUPLING KIT, PART #21335, & TIGHTEN COMPONENTS SECURELY.
- CONNECT TO GAS SUPPLY.

## **ZONE CONTROL PANEL FUNCTION AND INSTALLATION (Optional)**

With proper (5 PSIG) gas pressure supplied, spark ignition heaters will operate in the standard ON/OFF mode when electrically connected to a building environment controller or thermostat

If you require two stages of heat for greater temperature control, a two stage solenoid operated zone panel must be installed. This panel incorporates solenoids to control the first and second stage heating levels as well as a pressure regulator to set the firing rate of the first stage. Use of this panel requires a two stage thermostat or a building controller capable of controlling the heat in two stages.

When energized by a building controller or thermostat, the zone panel's first stage solenoid opens providing 2 PSIG, controlled by the regulator on the zone control panel, to the heater. This represents approximately half the heater's full output. If this level of heating does not satisfy the demand, the building controller or thermostat will call for the second stage of heating, full output, by energizing the second stage solenoid. This provides 5 PSIG to the heater.

As the heat demand is satisfied, the building controller or thermostat will reduce the firing rate by closing the second stage solenoid and lastly the first stage solenoid if heat is no longer needed.

Two stage zone panels are available in high or medium capacity configurations and will control the following quantity of heaters depending on fuel type.

<b>Solenoid Zone Control System</b>			
<b>Model and Heat Output</b>	<b>Fuel</b>	<b>Medium Capacity Panel</b>	<b>High Capacity Panel</b>
		<b>Quantity</b>	<b>Quantity</b>
I34 (34,200 BTUH)	L. P. Gas	7	20
	Natural Gas	4	20

All zone control panels must have an adjustable high pressure regulator installed upstream of the inlet of the panel. This regulator may be purchased from PSI as an optional accessory. The regulator must be capable of handling a maximum inlet pressure of 10 psi, while supplying an outlet pressure of 5 psi nominal.

Separate installation instructions accompany each zone panel.

## **INSTALLING DUST FILTER**

### **IMPORTANT**

This filter kit is designed to provide additional dust filtration capability and capacity for Infraconic heaters when installed in severely dusty environments.

1. Attach filter sleeve to injector body. The injector body tabs fit into the slots on the sleeve. Rotate the sleeve to lock it onto the injector body.
2. Position the filter onto the sleeve. Ensure all sleeve holes are covered by the filter.

3. Securely attach the filter to the sleeve using the beaded cable tie.
4. Ensure filter does not sag or touch heater's canopy.

**FIG. 6**

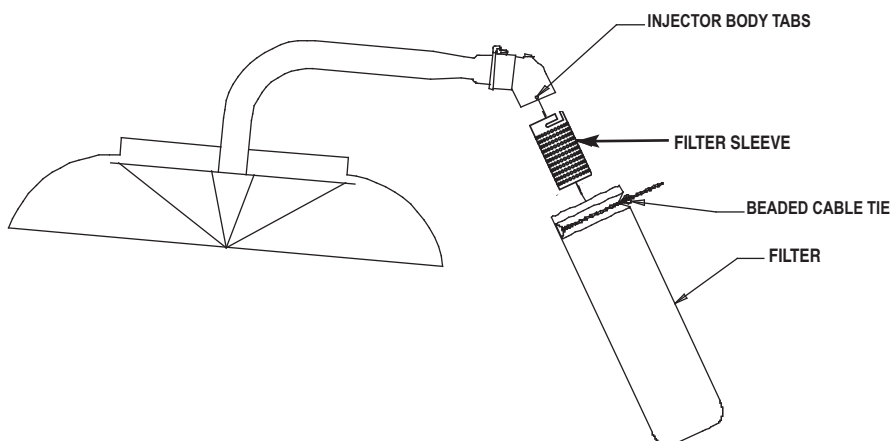

## Start-Up Instructions

Follow steps 1-5 on initial start up after heater installation by a qualified gas heater service person. For normal startup, simply turn the building thermostat above room temperature.

1. Connect the heater to an approved electrical supply and building's temperature control system.
2. Open all gas supply valves to the heater and check for gas leaks at all connections using approved leak detectors.
3. Energize the building's temperature control system to provide power to the heater.
4. Position the ON/OFF switch on the heater's control box to ON. See Fig. 7. The igniter will spark and ignition will occur.
5. Set the building's temperature control to desired temperature.

- It is normal for air to be trapped in the gas line on new installations.
- The heater may attempt more than one ignition trial before air is purged from the line and ignition occurs.

This heater includes a spark ignition control module for

purposes of controlling the timing of the ignition process of the heater as well as monitoring the safety functions. The control module is located in a control box at the gas inlet end of the heater. On a call for heat, the igniter will spark and the gas control valve will open shortly afterward. The igniter will continue to spark for approximately 10 seconds. Flame sense, as monitored by the ignition control, will keep the gas valve open and main burner in operation until proper temperature is achieved.

The ignition control module will make up to 3 trials for ignition. There will be a 15 second time span between each ignition trial. If ignition is not achieved after the third trial, a 15 minute wait period will occur. After the 15 minute time span has elapsed, the heater will make three more trials for ignition. This process will continue as long as there is a call for heat from the building's temperature control system.

**FIG. 7**

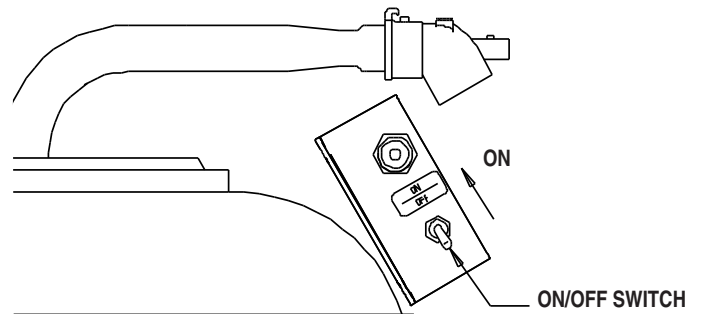

## Shut-Down Instructions

The building's environmental temperature control system will shut the heater down after proper temperature has been achieved.

If heater is to be shut down for cleaning, maintenance or service:

1. Shut off all gas supply valves to the heaters.
2. Allow heaters to burn off fuel gas remaining in the gas supply line.
3. Position the ON/OFF switch to OFF.
4. Disconnect the heater from its electrical supply.

## Cleaning Instructions

It is important to clean the heater and the optional dust filter on a regular basis to maintain proper combustion and to eliminate future problems. **Do not clean the heater with water or other liquids.**

The frequency of cleaning will vary depending upon livestock being raised and overall ventilation of the building.

Problems associated with lack of cleaning typically are:

- Black soot on inside of canopy.
- Gas backflashing in venturi tube or injector body.
- Burner flame appearing beyond outer cone.

### A. HEATER

#### **CLEANING WITH BACKPACK BLOWERS AND HEATER BLOWER**

**Blower Part No. 21170**

For general cleaning when the heaters do not have heavy accumulations of dust or dirt, use either a backpack type of blower or the heater blower.

Follow the same procedures for cleaning as listed for "Cleaning with Compressed Air".

If the dust and dirt cannot be removed effectively using the backpack blower or heater blower, then clean the heater using the Compressed Air cleaning method which follows.

#### **CLEANING WITH COMPRESSED AIR**

1. Turn off the gas supply to the heater and let the heater cool down.
2. Direct the air at the combustion cones, working your way around entire surface of cone assembly. See Fig. 8.
3. Blow air through air inlet opening in the injector body to blow back out any loosened dust through combustion cones.
4. Repeat Steps 2 and 3 until the cones and the venturi tube are no longer emitting dust.

5. Inspect the cones and venturi tube to make sure these areas are clean.
6. Return the heater to its normal hanging position and relight the heater.

**FIG. 8**

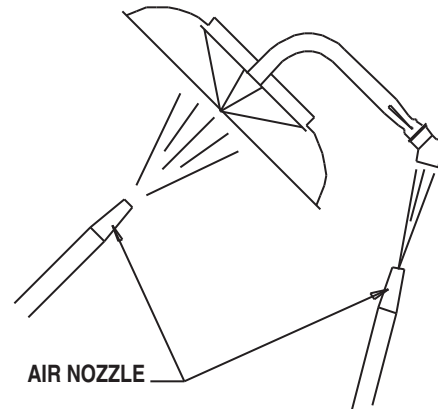

### B. FILTER

#### **1. During Continued Heater Use**

- Remove filter and shake off dust.
- Do not squeeze or tap filter while filter is installed on heater. Doing so will allow dust to be blown into venturi tube or combustion cones.

#### **2. After Continued Heater Use or Before Building Repopulation**

- Remove filter and shake off dust.
- Use compressed air or standard water faucet pressure to clean it.
- Do not use high pressure water, air, or a washing machine as filter material damage may occur.
- If water is used, squeeze out excess water from filter before installation.
- Let filter dry before lighting heater.

---

## Maintenance Instructions

1. Have your gas supplier check all gas piping annually for leaks or restrictions in gas lines. Also, at this time have your gas supplier clean out the sediment trap on the zone control panel of any debris that may have accumulated.
2. **The heater's surrounding area shall be kept clear and free from combustible materials, gasoline, and other flammable vapors and liquids.**
3. Regulators can wear out and function improperly. Have your gas supplier check the date codes on all regulators installed and check delivery pressures to the appliance to make sure that the regulator is suitable for continued use.
4. Regulators must be periodically inspected to make sure the regulator vents are not blocked. Debris, insects, insect nests, snow, or ice on a regulator can block vents and cause excess pressure at the appliance.
5. For safety as well as for optimum performance at the heater, it is necessary to keep the inside and the outside of the heater free of dust, dirt or any combustible material. If any operational component shows signs of rust or corrosion, replace the component immediately.
6. If any warning or instruction labels, dataplates, etc. become lost or hard to read, replace them immediately. Do not operate the heater until you have all instructions and can read and understand them.
7. Check overall condition of heater for cracked or damaged components, loose screws or bolts, etc. Replace any suspect components.
8. Check all hose and tubing assemblies for cracks, abrasions or ruptures. Replace any hoses that are suspect.

If it becomes apparent that a dark spot has formed part way up on the inner combustion cone or a build up of debris is occurring in the bottom of the inner cone, it will be necessary to clean out the combustion cone assembly. Refer to "Cleaning Instructions".

---

## Service Instructions

### GENERAL

---

 **WARNING**  
**Burn Hazard**

- Heater surfaces are extremely hot for a period of time after the heater has been shut down.
- Allow the heater to cool before performing service, maintenance, or cleaning.
- Failure to follow this warning will result in burns causing injury.

 **WARNING**  
**Fire and Explosion Hazard**

- Do not disassemble or attempt to repair any heater components or gas train components.
- All component parts must be replaced if defects are found.
- Failure to follow this warning will result in fire or explosions, causing property damage, injury, or death.

1. Close the fuel supply valve to the heater and disconnect the heater's electrical supply before

servicing unless it is necessary to have the valve open and electrical supply connected for your service procedure.

2. In servicing some components, it may be necessary to remove optional filter kit.
3. Remove the control box cover for access to ignition control, high limit switch, and on/off switch.
4. For reassembly, reverse the respective service procedure. Ensure gas connections are tightened securely.
5. After servicing, start the heater to ensure proper operation and check for gas leaks.
6. **Clean the heater's orifices with compressed air or a soft, dry rag. Do not use files, drills, broaches, etc. to clean the orifice holes. Doing so will enlarge the hole, causing combustion or ignition problems. Replace the orifice if it cannot be cleaned properly.**

## ON/OFF SWITCH

1. Disconnect the electrical leads from the ON/OFF switch.
2. Remove the rubber boot from the ON/OFF switch. See Fig. 9. Remove the switch from the control box.

**FIG. 9**

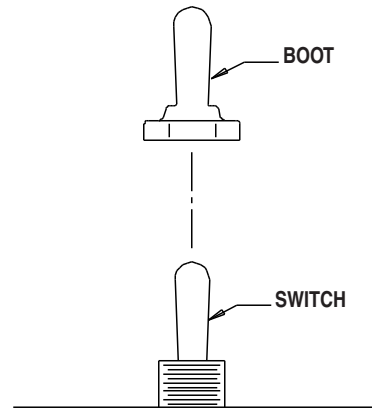

## IGNITION MODULE

- Handle the module at the edges of the board
- Do not touch or allow any contact to the module components, otherwise damage may occur.

1. Disconnect all electrical leads from the ignition control terminals.
2. Disconnect high voltage ignition lead.
3. Remove ignition control module mounting screws. See Fig. 10.

**FIG. 10**

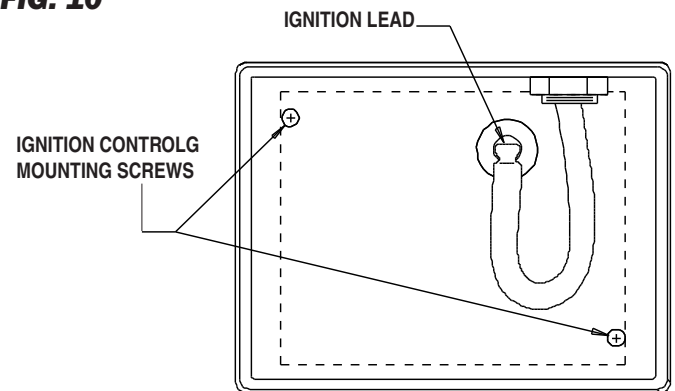

## BURNER ORIFICE

1. Remove valve grounding and attachment screw.
2. Remove injector body with gas control from venturi tube.
3. Using a 6 mm hex nut driver, remove the orifice.
4. Clean the orifice hole. Reinstall orifice into the orifice body. Do not overtighten the orifice as overtightening can strip the threads in the injector body.

**FIG. 11**

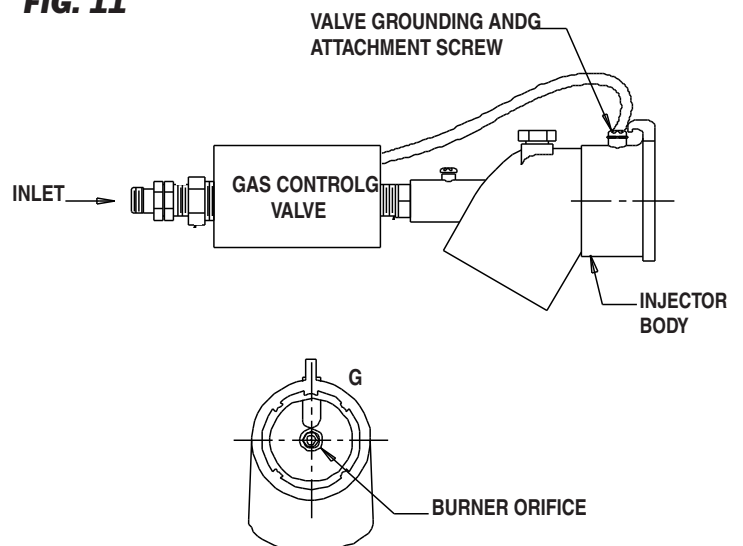

## HIGH VOLTAGE IGNITION LEAD

1. Disconnect the igniter lead from ignition module.
2. Loosen the water tight connector nut. See Fig. 12. Pull the ignition lead through this connection.
3. Disconnect the high voltage ignition lead from the ignitor. See Fig. 12.
4. Remove the connector nut from the ignition cable. This nut will be used on the replacement ignition cable.
5. Although the ignition lead is self locating, ensure it is positioned away from the venturi tube and the lead boot is covering the ignitor terminal.

**FIG. 12**

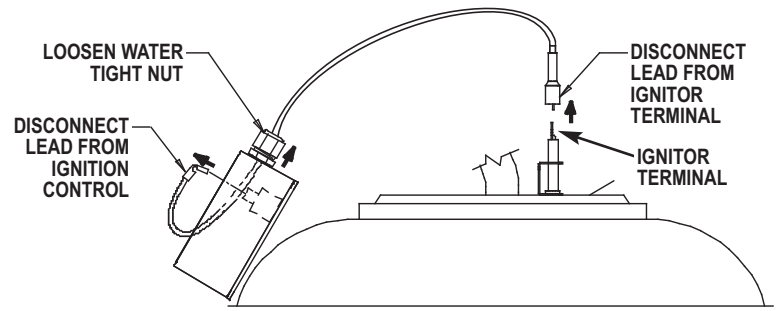

## IGNITER

1. Disconnect the ignition lead from the ignitor. Remove ignitor mounting screws. See Fig. 13.

**FIG. 14a**

**Fig. 13**

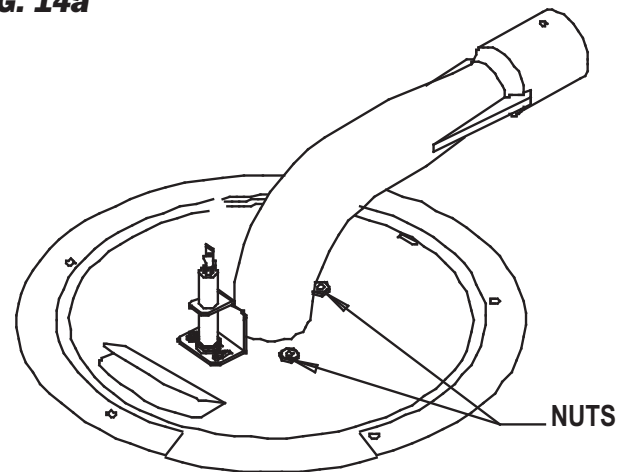
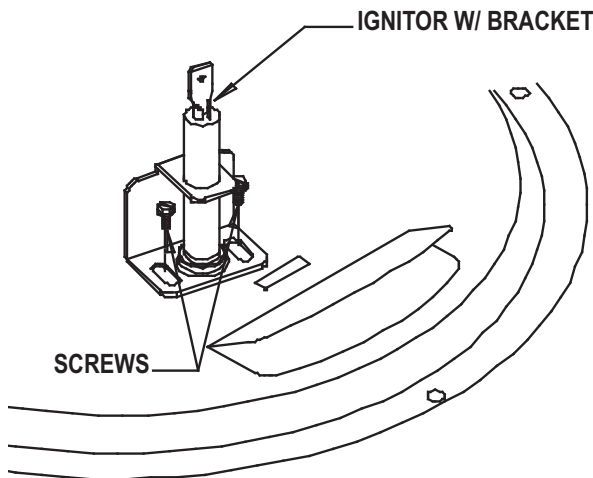

- b. Use gapping tool, part # 23967, to set the gap to .175 inches. See Fig.14b.

**FIG. 14b**



- c. Insert tool at opening between inner and outer combustion cone tips.

2. Remove the igniter from the heater. Clean the rod with steel wool or emery cloth.
3. The rod and its insulating ceramic body must be rigid within its mounting flange. If the rod or its body are capable of movement, the igniter will not be properly positioned to the combustion cone. The igniter must then be replaced.

### Adjusting Ignitor Gap

Ignitor gap may need to be adjusted if spark is still weak or non-existent after the igniter has been either cleaned or replaced. Refer to the following instructions.

- a. Ensure the three burner plate nuts are securely tightened. See Fig 14a.

- d. Position the tool between inner cone and ignitor tip. See Fig. 14c.

**FIG. 14c**

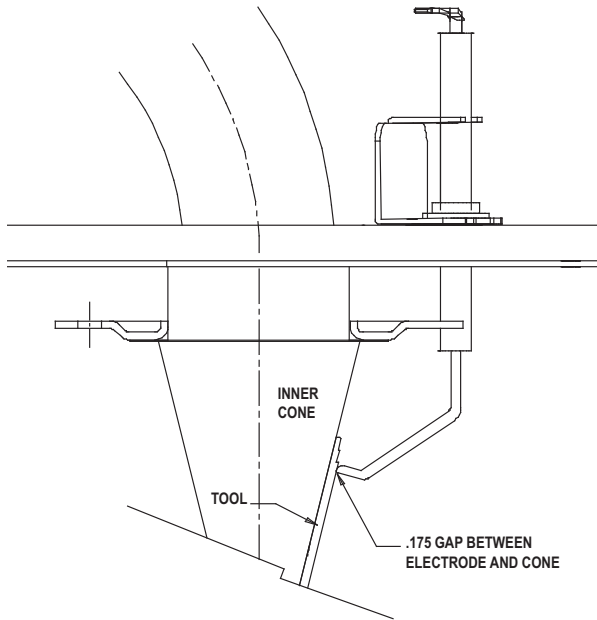

- e. If the gap exceeds the minimum to maximum tolerances of the tool, reset the gap:
- loosen igniter mounting screws.
  - reposition the igniter assembly until the gap is within the proper tolerances.
- f. Tighten the igniter mounting screws.

## HIGH LIMIT SWITCH

- This heater is equipped with a manual reset high limit switch. Its purpose is to disconnect the electrical supply to the ignition control board in the event of an overheat condition.
- An overheat condition is normally caused by:
  - Excessive fuel gas pressure.
  - Heater not being routinely cleaned.
  - Heater not properly hung. (See page 8.)

The high limit switch should be tested a minimum of once a year or anytime the heater is taken down for servicing. Refer to the following testing instructions.

2. Apply a small flame only to the sensing portion on the back of the switch. **Be careful not to melt the plastic housing of the switch when conducting this test.**
4. Within a minute, you should hear a pop coming from the switch, indicating the contacts of the switch have opened.
5. Allow the switch cool down before firmly pressing the reset button.
6. Check for electrical continuity across the switch terminals.
7. Reinstall the switch back into the heater.

**WARNING**  
Fire Hazard

- Do not operate the heater with the high limit switch bypassed.
- Operating the heater with a bypassed high limit switch may lead to overheating, possibly resulting in a fire, with subsequent damage to the heater and building, or loss of livestock.

**FIG. 15**

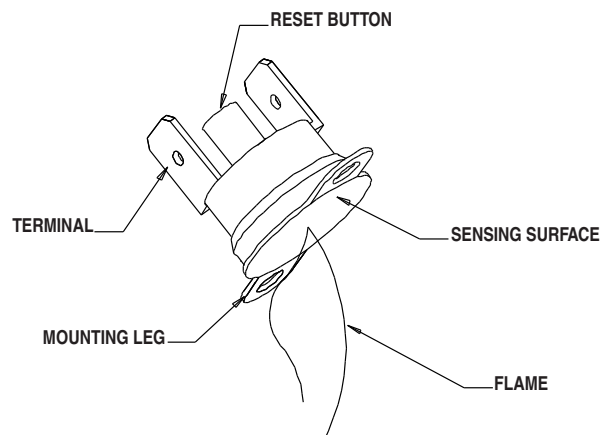

1. Remove the high limit switch from the control box.

## GAS CONTROL VALVE

1. Brush or blow off any dust in vicinity of gas control valve.
2. Disconnect the gas hose and remove control box cover.
3. Loosen water tight connector nut at the control box for the power supply leads of the control valve.
4. Disconnect the valve's electrical leads from the ignition module.
5. Remove the connector nut from the valve leads.
6. Loosen the valve ground and attachment screw at the injector body.
7. Remove bushing with hose adapter from control valve inlet. See Fig. 16.
8. Secure the gas valve adapter at the outlet of the gas control. Remove the control valve from adapter.

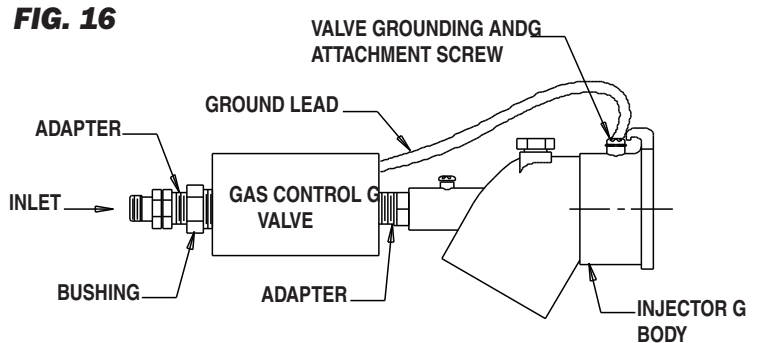

## GAS PRESSURE CHECKS

### A. Preparation

1. Obtain an L.B. White pressure gauge test kit - Part # 20736.
2. Disconnect the heater from the electrical supply and close the fuel supply valve to the heater.
3. Brush or blow off any dust and dirt on or in the vicinity of the gas control valve.
4. Disconnect the gas hose from the heater.

### B. Gauge Installation

1. Connect the pressure test kit between the heater and gas supply hose. See Fig. 17. Insure both gas shut-off valves on the test kit are in the closed position when connecting the kit to the heater and gas supply.
2. Reconnect the heater to its electrical supply and open the main fuel supply valve to the heater.
3. Open only the gas shut-off on the test kit which is connected to gas supply.
4. Light the heater.

### C. Reading Pressures

1. With the heater operating, the pressure gauge should read the pressure specified on the dataplate.
2. Does the reading on the gauge of the test kit agree with that specified on the dataplate? If so, then no further checking or adjustment is required. Proceed to Section D.
3. If the pressure does not agree with that specified on the dataplate, then the regulator controlling gas pressure to the heaters requires adjustment.

### D. Completion

1. Once gas pressure has been confirmed and/or properly set, close the fuel supply valve to the heater and allow the heater to burn off any gas remaining in the gas supply hose.
2. Disconnect the heater from its electrical supply.
3. Remove the gauge kit and reconnect the gas hose and electrical supply to the heater. Tighten securely.
4. Open the fuel supply valves and set building controller to desired temperature.

**FIG. 17**

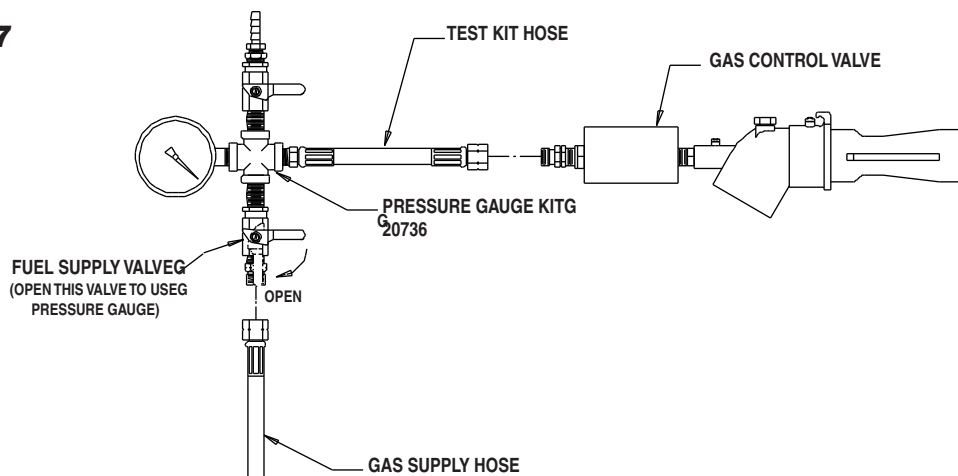

# Troubleshooting Guide

## READ THIS ENTIRE SECTION BEFORE BEGINNING TO TROUBLESHOOT PROBLEMS.

The following troubleshooting flow charts provide systematic procedures for isolating heater problems. The charts are intended for use by a QUALIFIED GAS HEATER SERVICE PERSON. **DO NOT SERVICE THE HEATER UNLESS YOU HAVE BEEN PROPERLY TRAINED.**

### TEST EQUIPMENT REQUIRED

The following pieces of test equipment will be required to troubleshoot this system with minimal time and effort.

- **Digital Multimeter** - For measuring voltage.
- **Pressure Gauge** - (Part No. 20736) For checking inlet pressures to the heaters.

### INITIAL PREPARATION

- Inspect the heater for damage.
- Clean the heater as necessary.

 **WARNING**  
**Electrical Shock and Burn Hazard**

- Troubleshooting this system may require operating the heater with the burner on. Use extreme caution when working on the heater.
- Failure to follow this warning may result in electrical shock or burns causing severe injury.

<u>Heater Problems</u>	<u>Page</u>
1.Heater does not light.....	19
2.Heater lights, but will not stay lit .....	20
3.Heater backflashes gas through air inlet. ....	20

Components should be replaced only after each step has been completed and replacement is suggested in the flow chart. Refer to the "Servicing" sections as necessary to obtain information on disassembly and replacement procedures of the component once the problem is identified by the flow chart.

### OPERATION SEQUENCE:

- A call for heat occurs from building thermostat.
- Line voltage is sent from building's temperature control to heater's ON/OFF switch.
- Switch sends power to ignition control through high limit switch.
  - Ignition control module begins ignition trial sequence
  - Ignition control sends high voltage to igniter electrode
  - Igniter sparks
  - Gas control solenoid opens
- Ignition occurs
  - Igniter continues to spark for 10 seconds until flame proving occurs
  - Ignition spark is shut off
  - Gas control solenoid stays open
- Ground warms to desired temperature
  - Building thermostat is satisfied
  - Heater shuts down
- Process is repeated on a call for heat

### IGNITION FAILURE SEQUENCE:

- Ignition control will make three ignition trials
  - Each trial lasts 10 seconds
  - 15 seconds time span between each trial
- If ignition control does not establish flame sense within ignition trial:
  - Ignition spark shuts off
  - Gas valve closes
- After three ignition trials, ignition control will wait for 15 minutes before retrying for ignition.
- This process will be repeated continually until the ignition problem is solved.
- To manually reset the ignition control:
  - Unplug the heater and plug it back in
  - OR
  - Turn the building temperature control to off and then back on.
  - OR
  - Turn ON/OFF switch on heater off. Wait 5 seconds, then turn back on.



**Problem 2**

**Heater Lights but will not Stay Lit**

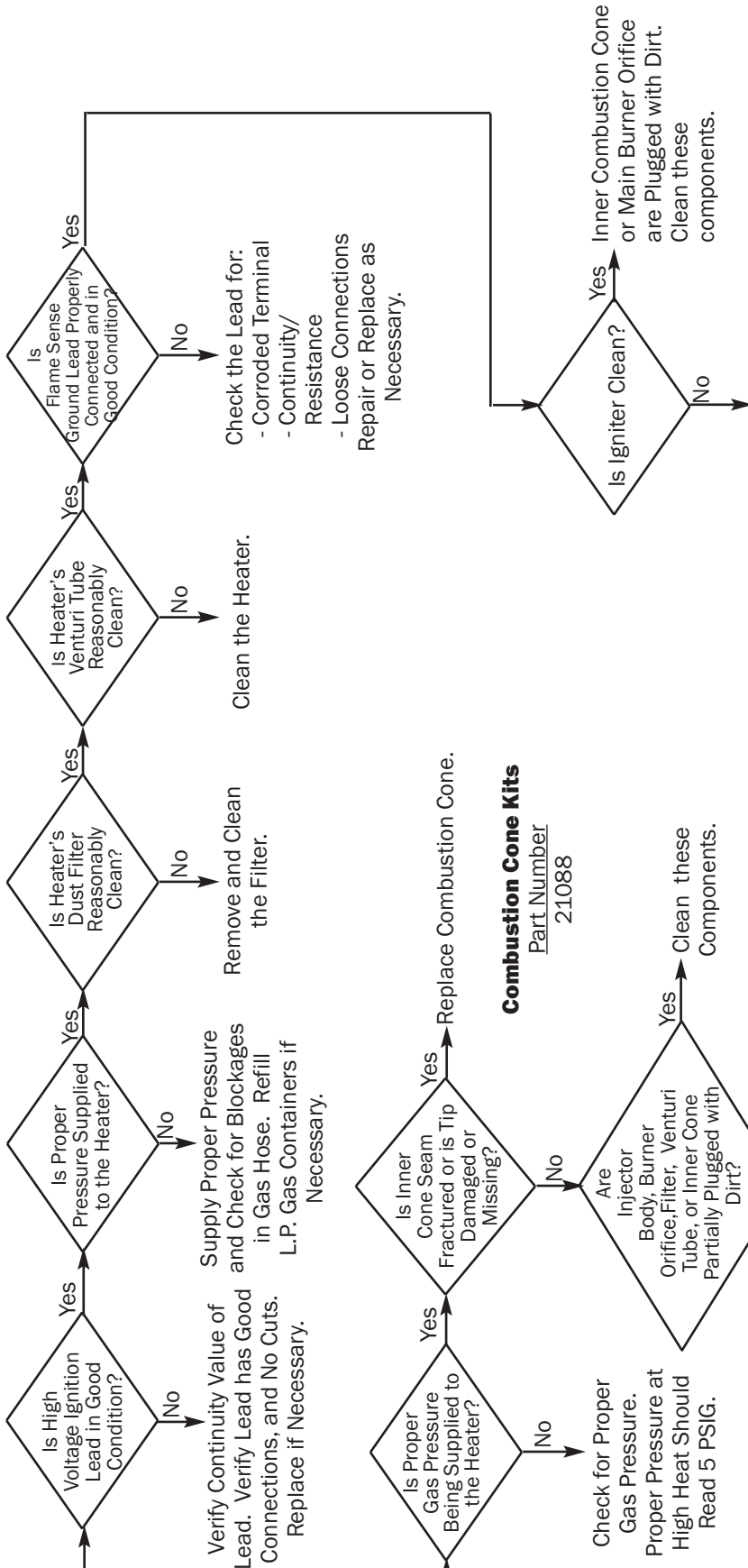

**Problem 3**

**Heater Backflashes Gas Through Air Inlet.**

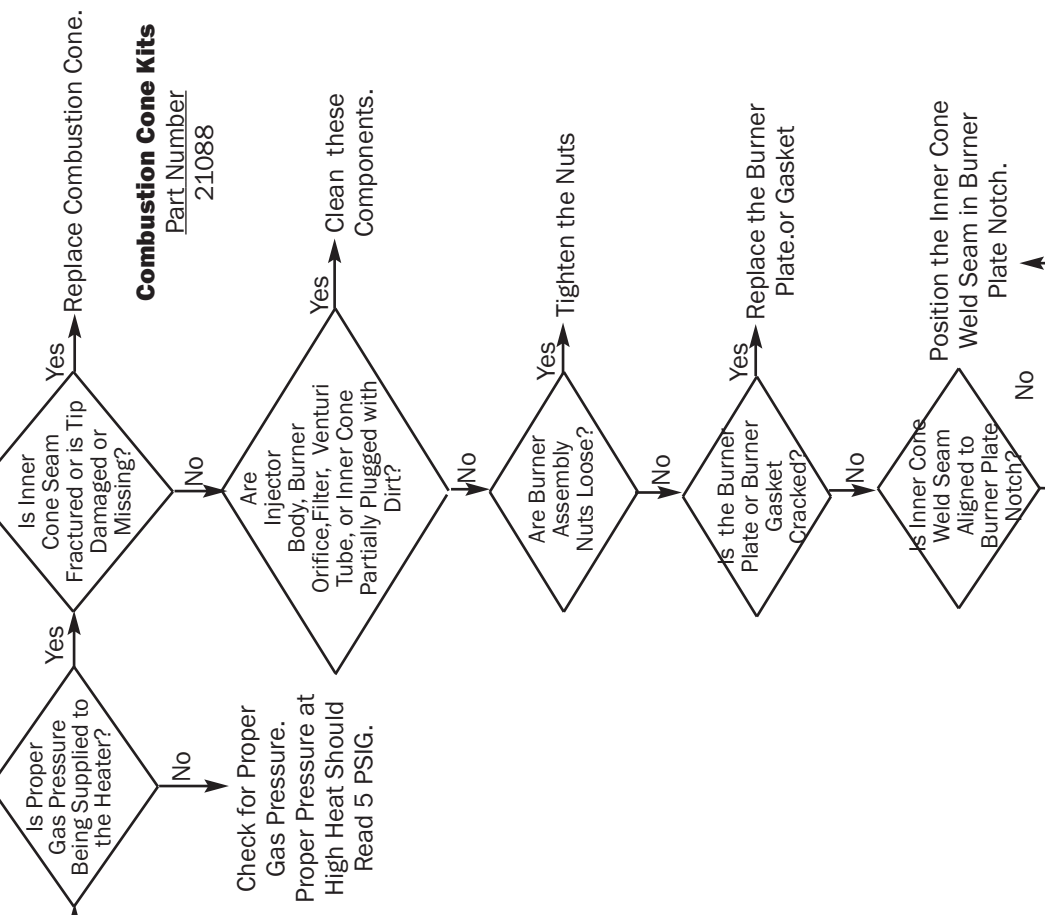

**Combustion Cone Kits**  
Part Number 21088

# Electrical Connection and Ladder Diagram

**CAUTION: REFER TO THE HEATER'S ELECTRICAL CONNECTION DIAGRAM WHEN SERVICING TO AVOID WIRING ERRORS AND HEATER MALFUNCTION. CHECK FOR PROPER OPERATION AFTER SERVICING.**

**WARNING: THIS HEATER MAY START AT ANY TIME**

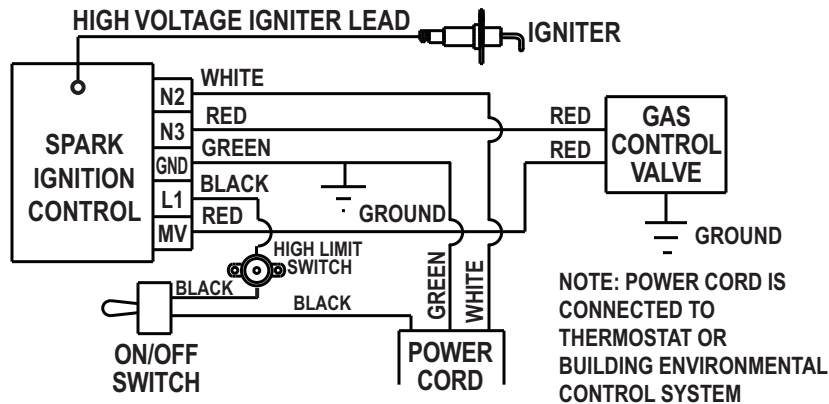

**ELECTRICAL CONNECTION DIAGRAM**

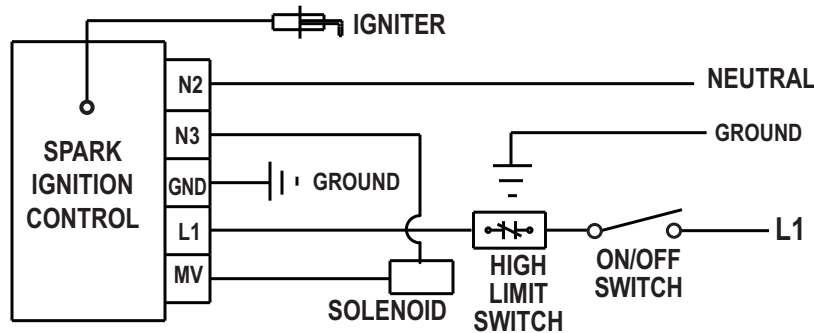

**ELECTRICAL LADDER DIAGRAM**

150-22824-A

**IF ANY OF THE ORIGINAL WIRE AS SUPPLIED WITH THE HEATER MUST BE REPLACED, IT MUST BE REPLACED WITH WIRING MATERIAL HAVING A TEMPERATURE RATING OF AT LEAST 302°F (150°C)**

---

## **Heater Component Function**

### **Burner Orifice**

Metering device used to feed gas to combustion cones at a specific flow rate.

### **Canopy**

Reflective aluminum heat shield for heater.

### **Double Combustion Chamber**

Made of special alloy steel. This is where combustion of gas occurs, providing radiant heat used in the warming process. Consists of small inner cone and large outer cone

### **Gas Control Valve**

Component that houses electromagnet which is energized by voltage and therefore opens or closes to supply or shut off the flow of gas to the burner.

### **Gas Hose**

Flexible connector used to convey gas from gas supply line to inlet of heater.

### **High Limit Switch**

Safety device wired into the heater's electrical supply which is used to open the electrical circuit to the ignition control module in the event of an overheat condition.

### **Igniter/Sensor**

Electrical ignition device used on automatic ignition control systems. Ignites gas by spark. The igniter also serves as a flame sensor on this heater to prove flame after ignition

### **Ignition Control Module**

Electronic device which controls the ignition sequence and operation of the heater.

### **Injector Body**

Allows combustion air to be drawn in to injector tube with gas flow for combustion.

### **Manual Shut Off Valve**

It's purpose is to shut off gas flow to the appliance if maintenance or service are required, or if an emergency situation occurs. When the handle on the manual valve is turned parallel to gas flow, the valve is completely open delivering full gas supply to the appliance. Turning handle perpendicular (90°) to gas flow shuts off gas flow.

### **On/Off Switch**

Simple electrical device used to connect or disconnect incoming voltage at the ignition control box on the heater.

### **Venturi Tube**

Tubular steel neck connecting the gas control valve and burner orifices to the combustion cones. Gas is fed to the combustion cones through the injector tube.

# Parts Identification

## PARTS SCHEMATIC

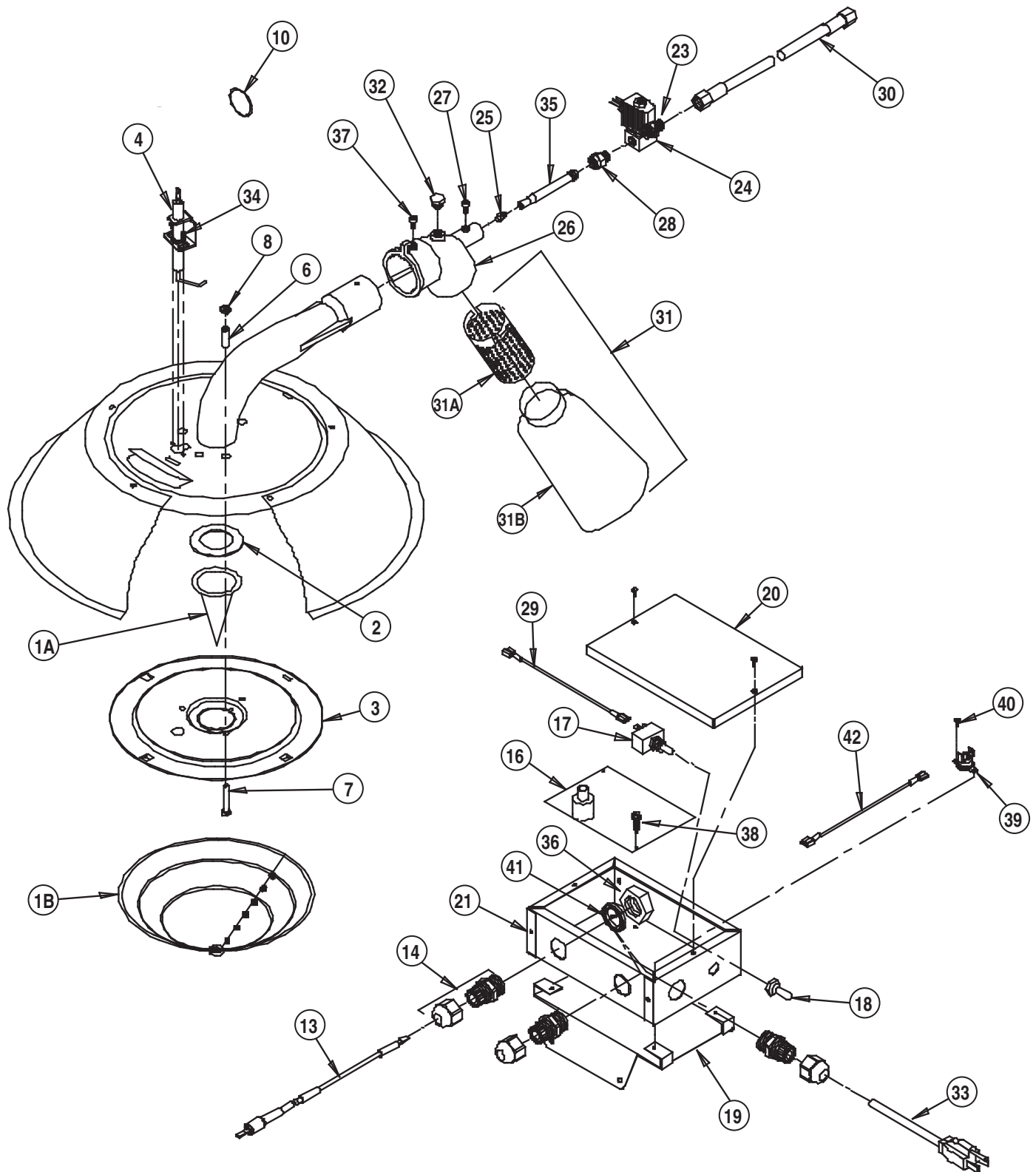

**PARTS LIST**

<b>Item</b>	<b>Description</b>	<b>Part Number</b>
1A	Inner Cone	09557
1B	Outer Cone	09556
	Combustion Cone Kit with Gasket	21088
2	Gasket	09560
3	Plate, Burner	22212-04
4	Igniter Kit	24050
6	Spacer	09568
7	Screw 10-32 x 1 1/2	23636
8	Nut 10-32	09578
10	Key Ring	09620
13	Lead, Igniter w/ Boot	23989
14	Connector, Liquid Tight	08948
16	Control, Direct Spark Ignition	22715
17	Switch, On/Off	22714
18	Boot, On/Off Switch	09916
19	Bracket, Control Box	24047
20	Control Box Cover w/ Gasket	23986
21	Control Box Bottom	23985
22	Bushing	01544
23	Adapter, Hose	23789
24	Valve, Gas Control w/ Electrical Leads and Screen	23729
25	Orifice, Burner	Propane Gas 26702 Natural Gas 26701
26	Injector Body w/ Air Register Plate	Propane Gas 20672 Natural Gas 21559
27	Retaining Screw for Injector Tube	09572
28	Adapter 1/8 NPT x 1/8 BSP	23707
29	Lead, Black, On/Off Switch to Ignition Control	22610
30	Hose, Gas 1/4 in. x 6 ft. Rigid x Swivel, Poultry	20495
	1/4 in. x 10 ft. Rigid x Swivel, Poultry	20496
	1/4 in. x 12 ft. Rigid x Swivel, Poultry	20497
	1/4 in. x 6 ft. Swivel Both Ends, Swine	20499
	1/4 in. x 10 ft. Swivel Both Ends, Swine	20242
	1/4 in. x 15 ft. Swivel Both Ends, Swine	20500
31	Filter Kit	20428
31A	Sleeve	20421
31B	Filter	23953
32	Plug	20358
33	Cord, Power	22704
34	Screw, Igniter Mounting	06658
35	Tube, Injector	09597
36	Lock Nut	08948
37	Screw, Injector Body	09575
38	Screw, Direct Spark Ignition	02330
39	High Limit Switch, Manual Reset	23148
40	Screw, High Limit Switch	22783
41	Gasket, Liquid Tight	22565
42	Wire, High Limit Switch	22610
43	Quick Coupling Kit, Female Coupling and Shut-Off (Not Illustrated)	21335
	Consisting Of:	
	Shut-Off Valve	05548
	Nipple, 1/4 in. Close	01142
	Coupling, Quick Disconnect	21328
	Bushing, 1/2 x 1/4	01519
44	Kit, 1/8 NPT Fitting ( Not Illustrated)	23406

---

# Warranty Policy

---

## EQUIPMENT

L.B. White Co., Inc. warrants that the component parts of its equipment are free from defects in material and workmanship, when properly installed, operated, and maintained in accordance with the Installation and Maintenance Instructions, safety guides and labels contained with each unit. If, **within 12 months from the date of purchase by the end user**, any component is found to be defective, L.B. White Co., Inc. will at its option, repair or replace the defective part or equipment, with a new part or equipment, F.O.B., Onalaska, Wisconsin.

A warranty card on file at L.B. White will automatically qualify a unit and its component parts for warranty consideration. If a warranty card is not on file, a copy of the bill of sale will be required to establish warranty qualification. If neither is available, the warranty period will be 12 months from date of shipment from L.B. White.

---

## PARTS

L.B. White Co., Inc. warrants that replacement parts purchased from the company and used on the appropriate L.B. White equipment are free from defects both in material and workmanship for **12 months from the date of purchase by the end user**. Warranty is automatic if a component is found defective within 12 months of the date code marked on the part. If the defect occurs more than 12 months later than the date code but within 12 months from the date of purchase by the end user, a copy of a bill of sale will be required to establish warranty qualification.

duration to the duration of the applicable warranty stated above. The remedies set forth above are the sole and exclusive remedies available hereunder. L.B. White will not be liable for any incidental or consequential damages directly or indirectly related to the sale, handling or use of the equipment, and in any event L.B. White's liability in connection with the equipment, including for claims based on negligence or strict liability, is limited to the purchase price.

The warranty set forth above is the exclusive warranty provided by L.B. White, and all other warranties, including any implied warranties or merchantability or fitness for a particular purpose, are expressly disclaimed. In the event any implied warranty is not hereby effectively disclaimed due to operation of law, such implied warranty is limited in

Some regions do not allow limitations on how long an implied warranty lasts, so the above limitation may not apply to you. Some regions do not allow the exclusion or limitation of incidental or consequential damages, so the above limitation or exclusion may not apply to you. This warranty gives you specific legal rights, and you may also have other rights which vary from state to state.

---

## Replacement Parts and Service

Contact your local L.B. White dealer for replacement parts and service or call the L.B. White Company, Inc. at

1-800-345-7200 for assistance. Be sure that you have your heater model number when calling.