



# Owner's Manual and Instructions

## Agricultural Animal Confinement Building Heaters



MODELS	OUTPUT	FUEL
AW250	73.3 kW	LPG



### SCAN THIS QR CODE

with your smartphone or visit <http://goo.gl/nksqZ> to view maintenance videos for L.B.White heaters.\*



\*Requires an app like QR Droid for Android or QR Reader for iPhone.

## Congratulations!

You have purchased the finest agricultural building heater available.

Your new L.B. White heater incorporates the benefits from the most experienced manufacturer of heating products using state-of-the-art technology.

We, at L.B. White, **thank you** for your confidence in our products and welcome any suggestions or comments you may have.....call us, at 001-608-783-5691.

### ATTENTION ALL USERS

This heater has been designed and developed as a direct gas-fired circulating heater for the heating of agricultural animal confinement buildings, and is approved for indoor or outdoor mounting. The heater has been evaluated by Novida Testing Services and conforms to the relevant requirements of SANS 1539:2008. If you are considering using this product for any application other than it's intended use, contact your local agent or the L. B. White Co., Inc. in the U.S.A. at 001-608-783-5691.



World Provider - Innovative Heating Solutions

411 Mason Street, Onalaska, WI USA 54650 ■ 001 608 783 5691 ■ 001 608 783 6115, fax ■ [www.lbwhite.com](http://www.lbwhite.com)



### GENERAL HAZARD WARNING

- Failure to comply with the precautions and instructions provided with this heater, can result in:
  - Death
  - Serious bodily injury or burns
  - Property damage or loss from fire or explosion
  - Asphyxiation due to lack of adequate air supply or carbon monoxide poisoning
  - Electrical shock
- Read this Owner's Manual before installing or using this product.
- Only properly-trained service people should repair or install this heater.
- Save this Owner's Manual for future use and reference.
- Owner's Manuals and replacement labels are available at no charge. For assistance, contact L.B. White at 001-608-783-5691.



### WARNING

- Proper gas supply pressure must be provided to the inlet of the heater.
- Refer to the heater's dataplate for proper gas supply pressure.
- Gas pressure in excess of the maximum inlet pressure specified at the heater inlet can cause fires or explosions.
- Fires or explosions can lead to serious injury, death, building damage or loss of livestock.
- Gas pressure below the minimum inlet pressure specified at the heater inlet may cause improper combustion.
- Improper combustion can lead to asphyxiation or carbon monoxide poisoning and therefore serious injury or death to humans and livestock.



### WARNING

#### Fire and Explosion Hazard

- Not for home or recreational vehicle use.
- Installation of this heater in a home or recreational vehicle may result in a fire or explosion.
- Fire or explosions can cause property damage or loss of life.

### FOR YOUR SAFETY

Do not store or use gasoline or other flammable vapors and liquids in the vicinity of this or any other appliance.

### FOR YOUR SAFETY

- If you smell gas:
1. Open windows.
  2. Don't touch electrical switches.
  3. Extinguish any open flame.
  4. Immediately call your gas supplier.



### WARNING

#### Fire and Explosion Hazard

- Keep solid combustibles a safe distance away from the heater.
- Solid combustibles include wood or paper products, feathers, straw, and dust.
- Do not use the heater in spaces which contain or may contain volatile or airborne combustibles.
- Volatile or airborne combustibles include gasoline, solvents, paint thinner, dust particles or unknown chemicals.
- Failure to follow these instructions may result in a fire or explosion.
- Fire or explosions can lead to property damage, personal injury or loss of life.



<b>SECTION</b>	<b>PAGE</b>
General Information	3
Heater Specifications	4
Safety Precautions	5
Installation Instructions	
General	7
Air Diverter Installation Instructions	9
Hanging Instructions	9
Sediment Trap Assembly	10
Thermostat Installation	10
Manual Shut-Off Valve, Hose and Regulator Assembly	10
Start-Up Instructions	11
Shut-Down Instructions	11
Cleaning Instructions	12
Maintenance Instructions	12
Service Instructions	
General	13
Motor and Fan Wheel Assembly	13
Air Proving Switch with Paddle	14
To Remove Control Box and Wire Harness from Heater	14
Igniter	15
Flame Sensor	15
Testing the Manual Reset High Limit Switch	15
Gas Pressure Checks	16
Troubleshooting Guide	17
Electrical Connection and Ladder Diagram	24
Heater Component Function	25
Parts Identification	
Parts Schematic	26
Parts List	27
Warranty Policy	28
Replacement Parts and Service	28

## General Information

This Owner's Manual includes all options and accessories commonly used on this heater. However, depending on the configuration purchased, some options and accessories may not be included.

When calling for technical service assistance, or for other specific information, always have model number, configuration number and serial number available. This information is contained on the dataplate. The dataplate is located on the interior of either the burner end or motor end door.

This manual will instruct you in the operation and care of your unit. Have your qualified installer review this manual with you so that you fully understand the heater and how it functions.

The gas supply line installation, installation of the heater, and repair and servicing of the heater requires continuing expert training and knowledge of gas heaters and should not be attempted by anyone who is not so qualified. See page 6 for definition of the necessary qualifications.

Contact your local L. B. White distributor or the L. B. White Co., Inc. for assistance, or if you have any questions about the use of the equipment or its application.

The L. B. White Co., Inc. has a policy of continuous product improvement. It reserves the right to change specifications and design without notice.

# Heater Specifications

<b>Model</b>	
<b>SPECIFICATIONS</b>	<b>AW250</b>
Fuel Type	<b>LPG</b>
Maximum Input per Hour	73.3 kW
Ventilation Air Required to Support Combustion (m <sup>3</sup> /hour)	1,885
Inlet Gas Supply Pressure Acceptable at the Inlet of the Heater for Purpose of Input Adjustment (kPa)	3.36
	<b>MAX.</b>
	2.74
	<b>MIN.</b>
Burner Manifold Pressure (kPa)	2.24
Motor Characteristics	Ball Bearing
	248 Watts 1130 RPM
Electrical Supply (Volts/Hz/Phase)	220-240/50/1
Amp Draw (Starting Amps Includes Igniter)	7.5
	<b>STARTING</b>
	2.6
	<b>CONTINUOUS OPERATION</b>
Dimensions L x W x H (cm)	78 x 46 x 72
Minimum Safe Distances From Nearest Combustible Materials (meters)	0.3
	<b>TOP</b>
	0.3
	<b>SIDES</b>
	0.3
	<b>BACK</b>
	1.83
	<b>BLOWER OUTLET</b>
	1.83
	<b>GAS SUPPLY</b>

# Safety Precautions

## **WARNING** **Asphyxiation Hazard**

- Do not use this heater for heating human living quarters.
- Do not use in unventilated areas.
- The flow of combustion and ventilation air must not be obstructed.
- Proper ventilation air must be provided to support the combustion air requirements of the heater being used.
- Refer to the specification section of the heater's Owner's Manual, heater dataplate, or contact the L.B. White Company to determine combustion air ventilation requirements of the heater.
- Lack of proper ventilation air will lead to improper combustion.
- Improper combustion can lead to carbon monoxide poisoning in humans leading to serious injury or death. Symptoms of carbon monoxide poisoning can include headaches, dizziness and difficulty in breathing.
- Symptoms of improper combustion affecting livestock can be disease, lower feed conversion, or death.

## **FUEL GAS ODOR**

**LPG has a man-made odorant added specifically for detection of fuel gas leaks. If a gas leak occurs, you should be able to smell the fuel gas. THAT'S YOUR SIGNAL TO GO INTO IMMEDIATE ACTION!**

- Do not take any action that could ignite the fuel gas. Do not operate any electrical switches. Do not pull any power supply or extension cords. Do not light matches or any other source of flame. Do not use your telephone.
- Get everyone out of the building and away from the area immediately.
- Close all LPG tank or cylinder fuel supply valves, or the main fuel supply valve located at the meter if you use natural gas.
- LPG is heavier than air and may settle in low areas. When you have reason to suspect a leak, keep out of all low areas.
- Use your neighbor's phone and call your fuel gas supplier and your fire department. Do not re-enter the building or area.
- Stay out of the building and away from the area until declared safe by the firefighters and your fuel gas supplier.
- **FINALLY**, let the fuel gas service person and the firefighters check for escaped gas. Have them air out the building and area before you return. Properly trained service people must repair the leak, check for further leakages, and then relight the appliance for you.

## **ODOR FADING -- NO ODOR DETECTED**

- **Some people cannot smell well. Some people cannot smell the odor of the man-made chemical added to LPG. You must determine if you can smell the odorant in these fuel gases.**
- Learn to recognize the odor of LPG. Local gas dealers will be more than happy to give you a "scratch and sniff" pamphlet. Use it to become familiar with the fuel gas odor.
- Smoking can decrease your ability to smell. Being around an odor for a period of time can affect your sensitivity to that particular odor. Odors present in animal confinement buildings can mask fuel gas odor.
- The odorant in LPG is colorless and the intensity of its odor can fade under some circumstances.
- If there is an underground leak, the movement of gas through the soil can filter the odorant.
- LPG odor may differ in intensity at different levels. Since LPG is heavier than air, there may be more odor at lower levels.
- **Always be sensitive to the slightest gas odor.** If you continue to detect any gas odor, no matter how small, treat it as a serious leak. Immediately go into action as discussed previously.

## **ATTENTION -- CRITICAL POINTS TO REMEMBER!**

- LPG has a distinctive odor. Learn to recognize these odors. (Reference "Fuel Gas Odor" and "Odor Fading" sections above.)
- If you have not been properly trained in repair and service of LPG fueled heaters, then do not attempt to light heater, perform service or repairs, or make any adjustments to the heater on LPG fuel system.
- Even if you are not properly trained in the service and repair of the heater, ALWAYS be consciously aware of the odor of LPG.
- A periodic "sniff test" around the heater or at the heater's joints; i.e. hose, connections, etc., is a good safety practice under any conditions. If you smell even a small amount of gas, CONTACT YOUR FUEL GAS SUPPLIER IMMEDIATELY. DO NOT WAIT!

# Safety Precautions

1. Do not attempt to install, repair, or service this heater or the gas supply line unless you have continuing expert training and knowledge of gas heaters.

Qualifications for service and installation of this equipment are as follows:

- a. To be a qualified gas heater service person, you must have sufficient training and experience to handle all aspects of gas-fired heater installation, service and repair. This includes the task of installation, troubleshooting, replacement of defective parts and testing of the heater. You must be able to place the heater into a continuing safe and normal operating condition. You must completely familiarize yourself with each model heater by reading and complying with the safety instructions, labels, Owner's Manual, etc., that is provided with each heater.
  - b. To be a qualified gas installation person, you must have sufficient training and experience to handle all aspects of installing, repairing and altering gas lines, including selecting and installing the proper equipment, and selecting proper pipe and tank size to be used. This must be done in accordance with all local, state and national codes as well as the manufacturer's requirements.
2. All installations and applications of L. B. White heaters must be carried out by a registered installer, and such installations shall meet the requirements of SANS 10087-1.
  3. Do not move, handle, or service heater while in operation or connected to a power or fuel supply.
  4. This heater may be installed in areas subject to washdown. This heater may only be washed on the external case assembly—see Cleaning Instructions. Do not wash the interior of the heater. Use only compressed air, soft brush or dry cloth to clean the interior of the heater and its components. After external washdown, do not operate this heater until it is completely dry. In any event, do not operate the heater for at least one hour after external washdown.
  5. For safety, this heater is equipped with a manual reset high-limit switch and an air flow switch. Never operate this heater with any safety device that has been bypassed. Do not operate this heater unless all of these features are fully functioning.
  6. Do not operate the heater with its door(s) open or panel removed.
  7. Do not locate fuel gas containers or fuel supply hoses within 6,10 meters of the blower outlet of the heater.
  8. Do not block air intakes or discharge outlets of the appliance. Doing so may cause improper combustion or damage to heater components leading to property damage or animal loss.
  9. The hose assembly shall be visually inspected on an annual basis. If it is evident there is excessive abrasion or wear, or if the hose is cut, it must be replaced prior to the heater being put into operation. The hose assembly shall be protected from animals, building materials, and contact with hot surfaces during use. The hose assembly shall be that specified by the manufacturer. See parts list.
  10. Check for gas leaks and proper function upon heater installation, before building repopulation or when relocating.
  11. This heater should be inspected for proper operation by a qualified service person before building repopulation and at least annually.
  12. Always turn off the gas supply to the heater if the appliance is not going to be used in the heating of livestock.
  13. This heater is wired for a three-wire electrical system. There is a hot lead, neutral lead and ground lead. The heater may or may not incorporate a plug in the power cord to the heater and the plug may or may not incorporate a pin for the ground wire. In any case, the heater must be properly connected into a grounded electrical supply using the ground lead in the power cord. Failure to use a properly grounded electrical supply can result in electrical shock, personal injury or death.
  14. Hot surface ignition heaters will make up to three trials for ignition. If ignition is not achieved after the third trial, the control system will "lock out" the gas control valve. If gas is smelled after system lock out has occurred, immediately close all fuel supply valves. Do not relight until you are sure that all gas that may have accumulated has cleared away. In any event, do not relight for at least 5 minutes.
  15. In a hanging type installation, rigid pipe or copper tubing coupled directly to the heater may cause gas leaks during movement, and therefore must not be used. Use only gas hose assemblies that are rated and approved for LP-gas and natural gas in a hanging type of installation.
  16. Installations not using the gas hose supplied with this heater must connect dimensionally using BS1387 Medium Duty Galvanized Steel Tube. (Aluminum piping or tubing shall not be used.)



### WARNING

#### Fire or Explosion Hazard.

Can cause property damage, severe injury or death.

- Disconnect power supply before wiring to prevent electrical shock or equipment damage.
- To avoid dangerous accumulation of fuel gas, turn off gas supply at the appliance service valve before starting installation, and perform gas leak test after completion of installation.
- Do not force the gas control knob. Use only your hand to turn the gas control knob. Never use any tools. If the knob will not operate by hand, the control should be replaced by a qualified service technician. Force or attempted repair may result in fire or explosion.

1. Read all safety precautions and follow L. B. White recommendations when installing this heater. If during the installation or relocating of heater, you suspect that a part is damaged or defective, call a qualified service agency for repair or replacement.
2. Make sure the heater is properly positioned before use and is hung level. Observe and obey all minimum safe distances of the heater to the nearest combustible materials. Minimum safe distances are given on the heater nameplate and on page 4 of this manual.
3. Ensure the heater has the proper second stage gas regulator for the application. A regulator must be connected to the gas supply so that gas pressure at the inlet to the gas valve is regulated within the range specified on the heater's dataplate at all times. Contact your gas supplier, or the L. B. White Co., Inc. if you have any questions
4. Do not exceed input rating stamped on the dataplate of the heater. Do not exceed the burner manifold pressure stated on the dataplate. Do not use an orifice size different than specified for the specific input rating of this heater, fuel type configuration and altitude.
5. The heater may be used either indoors or outdoors. When the heater is mounted outdoors, use only the ductwork supplied in the outdoor mounting kit.
6. For heaters intended for outdoor installation, the heater is to be installed at least 46 cm above the ground or to a height that would prevent snow blockage of heater's air inlet.
7. The unit's gas regulator (with pressure relief valve) should be installed outside of building. Any regulators inside the buildings must be properly vented to the outside. Local, state and national codes always apply to regulator installation. Natural gas regulators with vent limiting device may be mounted indoors without venting to outdoors.
8. All gas pressure regulators must be installed in strict accordance with the manufacturer's safety instructions. These instructions accompany each regulator.
9. Insure that all accessories that ship within the heater have been removed from inside of heater and installed. This pertains to air diverters, hose, regulators, etc.
10. Make certain that a sediment trap is installed at the gas valve inlet to prevent foreign materials (pipe compound, pipe chips and scale) from entering the gas valve. Debris blown into the gas valve may cause that valve to malfunction resulting in a serious gas leak that could result in a possible fire or explosion causing loss of products, building or even life. A properly installed sediment trap will keep foreign materials from entering the gas valve and protect the safe functioning of that important safety component.
11. Any heater connected to a piping system must have an accessible, approved manual shut off valve installed within 1.83 meters of the heater it serves.
12. Check all connections for gas leaks using approved gas leak detectors. Gas leak testing is performed as follows:



### WARNING

#### Fire and Explosion Hazard

- Do not use open flame (matches, torches, candles, etc.) in checking for gas leaks.
- Use only approved leak detectors.
- Failure to follow this warning can lead to fires or explosions.
- Fires or explosions can lead to property damage, personal injury or loss of life.

- Check all pipe connections, hose connections, fittings and adapters upstream of the gas control with approved gas leak detectors.
- In the event a gas leak is detected, check the components involved for cleanliness and proper application of pipe compound before further tightening.
- Furthermore tighten the gas connections as necessary to stop the leak.
- After all connections are checked and any leaks are stopped, turn on the main burner.
- Stand clear while the main burner ignites to prevent injury caused from hidden leaks that could cause flashback.
- With the main burner in operation, check all connections, hose connections, fittings and joints as well as the gas control valve inlet and outlet connections with approved gas leak detectors.

- 
- If a leak is detected, check the components involved for cleanliness in the thread areas and proper application of pipe compound before further tightening.
  - Tighten the gas connection as necessary to stop the leak.
  - If necessary, replace the parts or components involved if the leak cannot be stopped.
  - Ensure all gas leaks have been identified and repaired before proceeding.
13. A qualified service agency must check for proper operating gas pressure upon installation of the heater.
  14. Light accordance to instructions on the heater or within owner's manual.
  15. It is extremely important to use the proper size and type of gas supply line to assure proper functioning of the heater. Contact your fuel gas supplier for proper line sizing and installation.
  16. It is extremely important to use the proper size and type of gas supply line to assure proper functioning of the heater. Contact your fuel gas supplier for proper line sizing and installation.
  17. This heater is configured for use with either L.P. vapor withdrawal only. Do not use the heater in an L.P. gas liquid withdrawal system or application. If you are in doubt, contact the L. B. White Co., Inc.
  18. Eventually, like all electrical/mechanical devices, the thermostat can fail. Thermostat failure may result in either an underheating or overheating condition which may damage critical products and/or cause animal injury or death. Critical products and/or animals should be protected by a separate back-up control system that limits high and low temperatures and also activates appropriate alarms.
  19. Take time to understand how to operate and maintain the heater by using this Owner's Manual. Make sure you know how to shut off the gas supply to the building and also to the individual heater. Contact your fuel gas supplier if you have any questions.
  20. Any defects found in performing any of the service or maintenance procedures must be eliminated and defective parts replaced immediately. The heater must be retested by properly qualified service personnel before placing the heater back into use.



## AIR DIVERTER INSTALLATION INSTRUCTIONS

(Appearance of the outlet on heater may vary from model to model.)

1. Air diverters can be installed in the heater outlet to provide direction to the heated air as it exits the heater. Refer to Fig. 1. Air diverters can be installed to direct the air in either two 45 degree paths or in one 45 degree direction.
2. The air diverters may require hand forming prior to installation. Make 90 degree bends utilizing the perforations provided. The diverter halves should then have the shape as shown in Fig. 1.
3. The air diverter's tabs on each half will pop into the blower outlet between the inside of the case assembly and the blower housing outlet. If the notched tabs do not pop into the blower outlet, loosen the blower outlet screws. Doing this provides a gap into which you can insert the tabs. Retighten the screws after installation.

**FIG. 1** (Typical installation allowing two directions of air movement.)

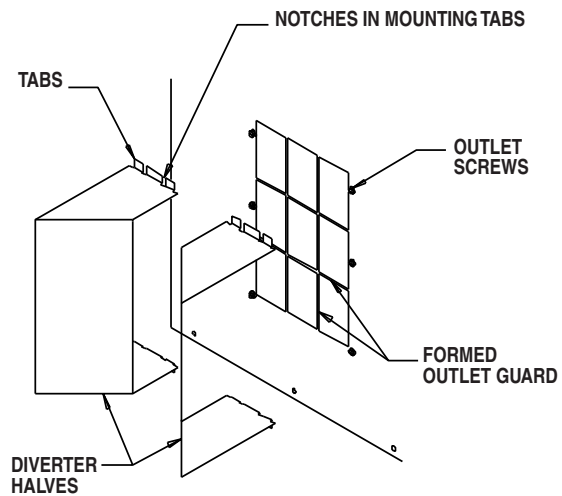

ALTERNATE AIR DIVERTER ARRANGEMENTS



## HANGING INSTRUCTIONS

1. Assemble according to Fig.3 and tighten all eyebolts securely.
2. Be sure heater is securely fastened and is hanging level. (Check crosswise and lengthwise.)
3. See Fig. 2 for **typical** indoor installation. In any animal confinement building, consideration must be given to making sure the heater is located away from the livestock so that livestock cannot knock the heater, tear it loose from its mounting, or damage the heater or its gas supply line in any way. Make sure you observe and obey minimum clearance distances to combustible materials as stated in the specification section of this owner's manual and on the heater dataplate.

**FIG. 3**

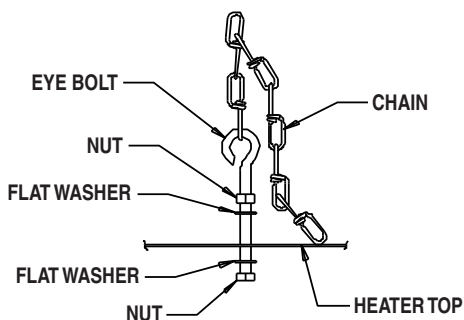

**FIG. 2**

NOTE: REGULATORS SHOULD ALWAYS BE MOUNTED OUTDOORS. IF CIRCUMSTANCES FORCE INSTALLING THE REGULATOR INDOORS, THE REGULATOR'S VENT MUST BE VENTED OUTDOORS USING VENT LINE NO SMALLER THAN VENT OPENING.

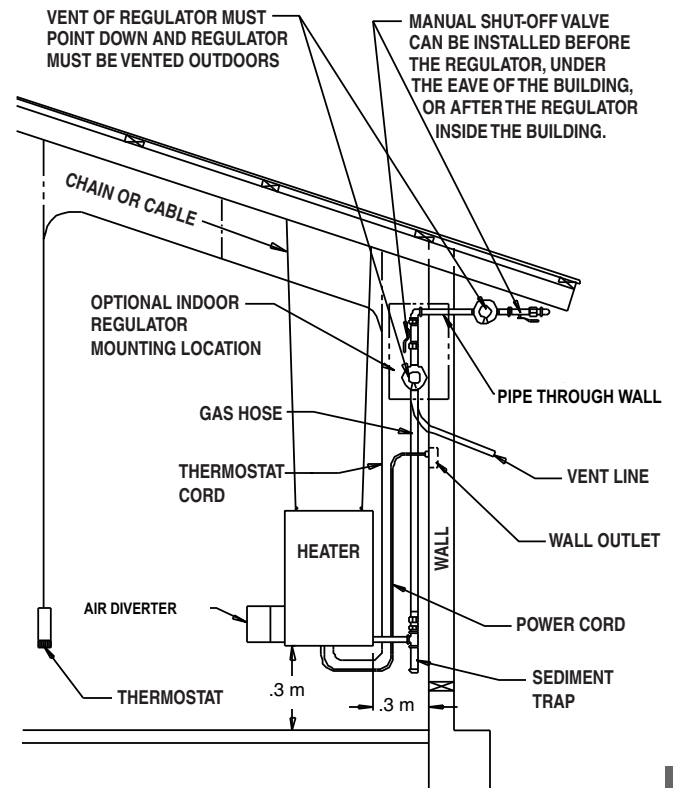

## SEDIMENT TRAP ASSEMBLY

Assemble the tee, nipples and cap together and tighten securely. The sediment trap assembly must always be mounted in a vertical position. Use pipe thread compound that is resistant to LPG. Check all connections for gas leaks using approved gas leak detectors.

**FIG. 4**

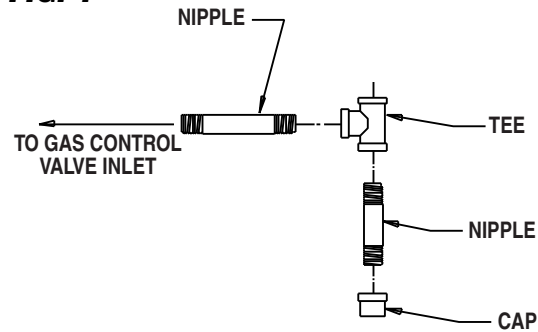

## THERMOSTAT INSTALLATION

**WARNING**  
Electrical Shock Hazard

- Disconnect the electrical supply before connecting the thermostat to the heater.
- Failure to follow this warning can result in electrical shock, leading to personal injury or death.

1. To Connect the Direct Wired Thermostat Kit to the Control Box on the Heater:
  - a. The installation and wiring of a thermostat must be done by an electrician or someone properly qualified.

- b. The thermostat may use 18 gauge, 3 wire (with ground) cord to handle the voltage being supplied to the thermostat.
- c. The heater must be tested for proper operation after the thermostat has been connected.

## MANUAL SHUT-OFF VALVE, HOSE AND REGULATOR ASSEMBLY

1. Always use approved pipe thread compound suitable for use with LPG on the threaded connections.
2. Assemble the components together according to the figure. This view is to show general assembly of the components only.
3. Tighten all connections securely.
4. Check all connections for gas leaks using approved gas leak detectors.

**FIG. 5**

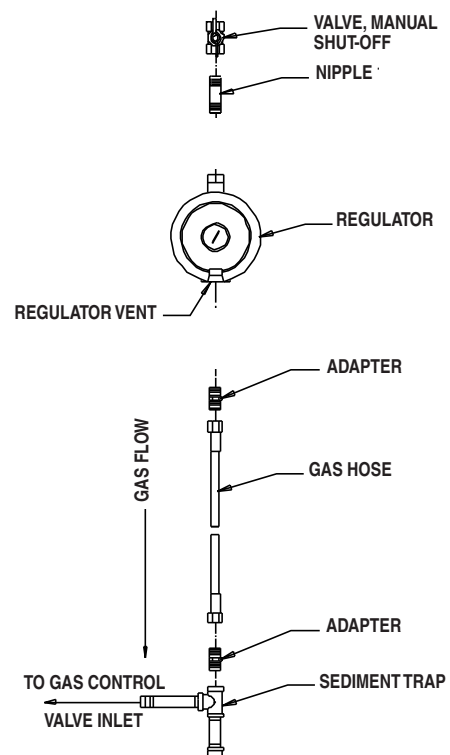

---

## Start-Up Instructions

Follow steps 1 - 6 on initial start-up after heater installation by a qualified gas heater service person. For normal start-up, simply set the thermostat above room temperature. The heater will start.

1. Open all manual fuel supply valves and check for gas leaks using approved leak detectors. The gas control valve on the heater has a manual shut-off feature incorporated into the valve assembly and will be located within the gas control and electrical enclosure. Open the enclosure and make sure the indicator on the valve is turned to the “on” position. Close and latch the enclosure. See Fig. 6.

**FIG. 6**

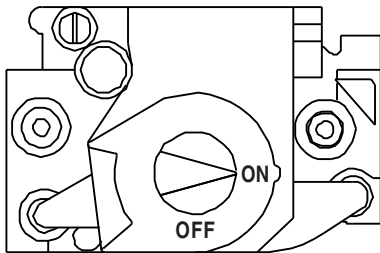

2. Connect the electrical cord to an approved electrical outlet.
3. Set the thermostat (if supplied) to desired room temperature.
4. This heater includes a direct ignition control module for purposes of controlling the timing of the ignition process of the heater as well as monitoring of the safety functions. The module is contained within the metal control box. On the module is a red light

emitting diode (LED). This LED indicates the status of the heater. The LED is visible external of the control enclosure through the plastic eye. A constant light from the LED is an indicator that the heater is functioning correctly. Any flash pattern by the LED is indicative that there is a problem in the operation of the heater. Refer to the troubleshooting decal on the access panel at the fan motor end of the heater for assistance in troubleshooting. Only qualified and properly trained personnel shall service or repair the heater.

5. On a call for heat, the motor will start up and run for about 5 seconds and then stop. This “pre-purge” is a safety feature and a normal operational characteristic prior to ignition taking place. After the motor has stopped, the lighter will heat up (approximately 15 seconds). After igniter warm up time has been achieved, the motor will start again and shortly thereafter ignition will occur.

NOTE: It is normal for air to be trapped in the gas hose on new installations. The heater may attempt more than one trial for ignition before the air is finally purged from the line and ignition takes place.

6. The HSI control will make up to three trials for ignition. Each trial for ignition will take approximately 20 seconds. The first two trials for ignition will occur within 40 seconds if ignition is not achieved. A 15 minute wait period will then begin. After the 15 minute time span has elapsed, the control will make three more trials for ignition. If ignition is not achieved after the final trial, the control system will “lock out” and the “three flash” light pattern will be indicated by the LED.

---

## Shut-Down Instructions

If the heater is to be shut down for cleaning, maintenance or repair, follow steps 1 - 5. Otherwise, simply turn thermostat to off or no heat for standard shut down.

1. Close all manual fuel supply valves.
2. With the heater lit, allow heater to burn off excess fuel in gas supply hose.

3. Turn the indicator on the gas control to off.
4. Turn thermostat to off or no heat position.
5. Disconnect the heater from the electrical supply.

## Cleaning Instructions



### **WARNING** Fire, Burn, and Explosion Hazard

- This heater contains electrical and mechanical components in the gas management, safety and airflow systems.
- Such components may become inoperative or fail due to dust, dirt, wear, aging, or the corrosive atmosphere of an animal confinement building.
- Periodic cleaning and inspection as well as proper maintenance are essential to avoid serious injury or property damage.

1. Before cleaning, shut off all gas supply valves and disconnect the electrical supply.
2. The heater should have dirt or dust removed periodically:
  - a. After each flock or between building repopulation, give the heater a general cleaning using compressed air or a soft brush on its interior and exterior. At this time, dust off the motor case to prevent the motor from over-heating and shutting the heater down.
  - b. At least once a year, give the heater a thorough cleaning. At this time, remove the fan and motor assembly and brush or blow off the fan wheel, giving attention to the individual fan blades. Make sure the burner air inlet venturi ports and the throat of the casting are free of dust accumulation and the area between the heat chamber top and inside case is also free of dust. Additionally, the flame sensor should be removed and cleaned according to the service instructions within this Owner's Manual.
  - c. When washing with water, observe and obey the Warning within these Cleaning Instructions. This same Warning is also supplied on the heater.



### **WARNING**

This heater may be washed only on the external case assembly provided:

- A. The heater is disconnected from the electrical supply.
- B. All access panels are securely closed.
- C. Water spray nozzle shall not discharge within 1.83 m. of the heater.
- D. The water pressure does not exceed 3.1 bar for 10 seconds on each side of heater.
- E. The heater is not reconnected to electrical supply for a minimum of 1 hour or until the heater is thoroughly dry.

Improper cleaning of the heater can cause severe personal injury or property damage due to water and/or cleaning solution:

1. In electrical components, connections and wires causing electrical shock or component failure.
2. On gas control components causing corrosion which can result in gas leaks and fire or explosion from the leak.

Clean internal components of the heater with a soft, dry brush or cloth, or compressed air.

## Maintenance Instructions

1. Have your gas supplier check all gas piping annually for leaks or restrictions in gas lines. Also, at this time have your gas supplier clean out the sediment trap of any debris that may have accumulated.
2. **The appliance area shall be kept clear and free from combustible materials, gasoline, and other flammable vapors and liquids.**
3. Regulators can wear out and function improperly. Have your gas supplier check the date codes on all regulators installed and check delivery pressures to the appliance to make sure that the regulator is reliable.
4. Regulators must be periodically inspected to make sure the regulator vents are not blocked. Debris, insects, insect nests, snow, or ice on a regulator can block vents and cause excess pressure at the appliance.

**WARNING**  
**Burn Hazard**

- Heater surfaces are hot for a period of time after the heater has been shut down.
- Allow the heater to cool before performing service, maintenance, or cleaning.
- Failure to follow this warning will result in burns causing injury.

**WARNING**  
**Fire and Explosion Hazard**

- Do not disassemble or attempt to repair any heater components or gas train components.
- All component parts must be replaced if defects are found.
- Failure to follow this warning will result in fire or explosions, causing property damage, injury, or death.

1. Close the fuel supply valve to the heater and disconnect the electrical supply before servicing unless necessary for your service procedure.
2. Open side panels for access to heater components.
3. Disconnect the appropriate electrical leads for the component being replaced.

4. The thermostat, and high limit switch can be tested by jumpering the suspect part out of the electrical circuit:
  - Reconnect the electrical supply and open fuel supply valves.
  - If the heater lights, the component is defective and must be replaced.
  - Do not operate the heater with the component jumpered. Replace the part immediately.
  - An alternate method for checking the components is to perform a continuity check.
5. Do not jumper the air proving switch. If jumpered, the ignition control will not allow heater operation. Test the air proving switch for continuity. If defective, replace the switch
6. For reassembly, reverse the respective service procedure. Ensure gas connections are tightened securely.
7. After servicing, start the heater to ensure proper operation. Check for gas leaks with approved leak detectors.
8. Clean the heater's orifice with compressed air or a soft, dry rag. Do not use files, drills, broaches, etc. to clean the orifice. Doing so may enlarge the hole, causing combustion or ignition problems. Replace the orifice if it cannot be cleaned properly.

## MOTOR AND FAN WHEEL ASSEMBLY

1. Remove the screws securing the motor mounting plate to the fan housing.
2. Pull the fan and motor assembly from the housing.
3. Loosen the square head set screw(s) on the fan wheel with a wrench.
4. Pull the fan wheel from the motor shaft. Use a wheel puller if necessary.
5. Remove the four (4) nuts securing the motor to the mounting plate.

- Fan wheel to motor mount plate spacing must be adjusted to proper clearance before tightening the fan wheel to the motor shaft.
- Make sure that set screw(s) of the fan are on the "flats" of motor shaft when tightening.

**Clearance**  
3.2 mm

**FIG. 7**

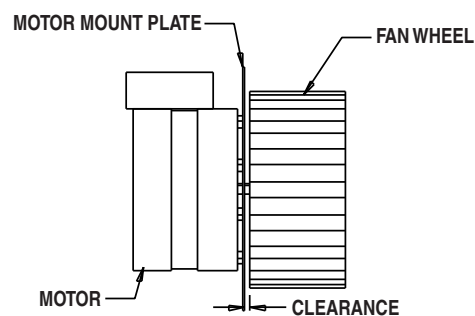

## AIR PROVING SWITCH WITH PADDLE

1. Open the case access panel on the control box end of the heater.
2. Remove the two (2) sheet metal screws holding the switch with bracket to blower housing. Remove the assembly by turning the switch assembly 90° so the paddle on the switch arm can be pulled through the oblong hole on side of fan housing.
3. Disconnect the leads from the air proving switch.
4. To replace the switch, reverse the above procedure. The replacement switch will be pre-assembled to its mounting bracket.

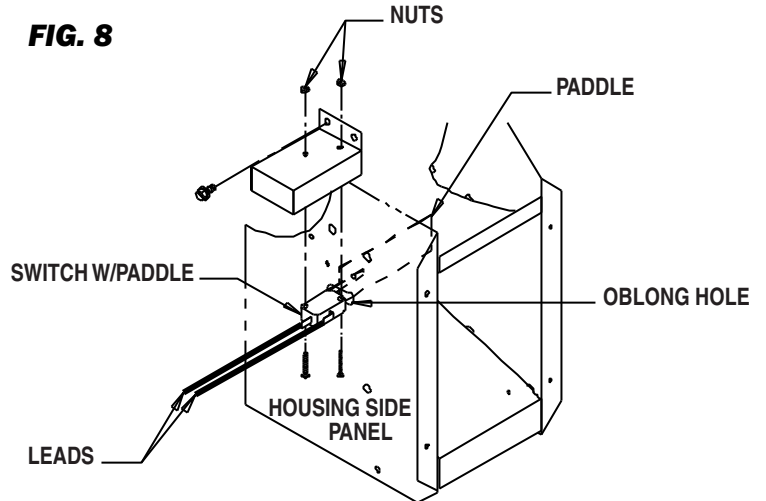

## TO REMOVE CONTROL BOX AND WIRE HARNESS FROM HEATER

1. Open the motor access panel.
2. Disconnect flame sensor lead and high voltage ignition lead from ignition control and route these back through the rubber grommet in the back of the control box.
3. Trace and disconnect all remaining electrical leads which exit the back of the control box from the components or the areas to which these leads are connected.
4. Remove liquid tight connector nut and sealing washer on inside of control box. Pull connector with leads from back of control box.
5. Remove the three (3) screws on each side of the control panel and remove the control box from the heater.
6. To assemble, reverse above procedure.

**FIG. 9**

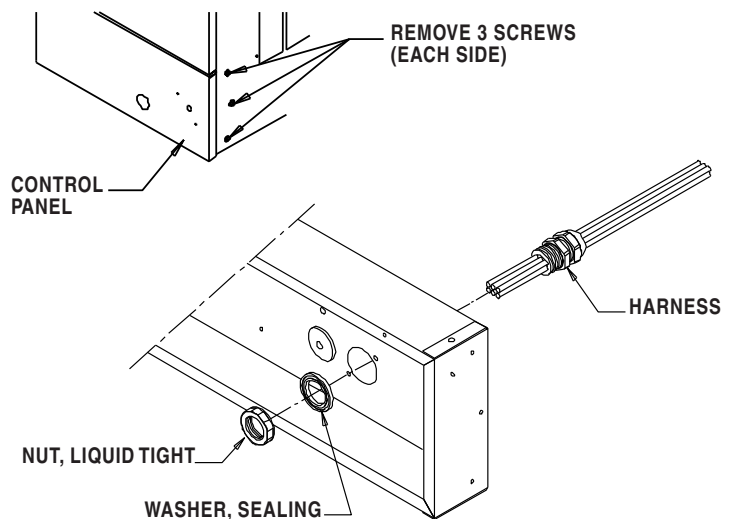

1. See Fig. 10 for disassembly.
2. Position the replacement igniter so its lip and mounting slot and screw hole of igniter bracket.
3. Reassemble remaining parts.
4. Tighten the mounting screws snugly.  
- Do not overtighten the igniter. Overtightening can cause cracks in igniter base, leading to failure.

**FLAME SENSOR**

1. Remove the sensor from its mounting bracket. See Fig. 10. Clean the sensor rod with steel wool or emery cloth. Rub briskly to remove build up of dust, dirt and aluminum oxide.
2. Check the flame sensor's insulator base for cracks. If cracks are found, replace the sensor.
3. Position the flame sensor as shown in Fig. 11.

**FIG. 10**

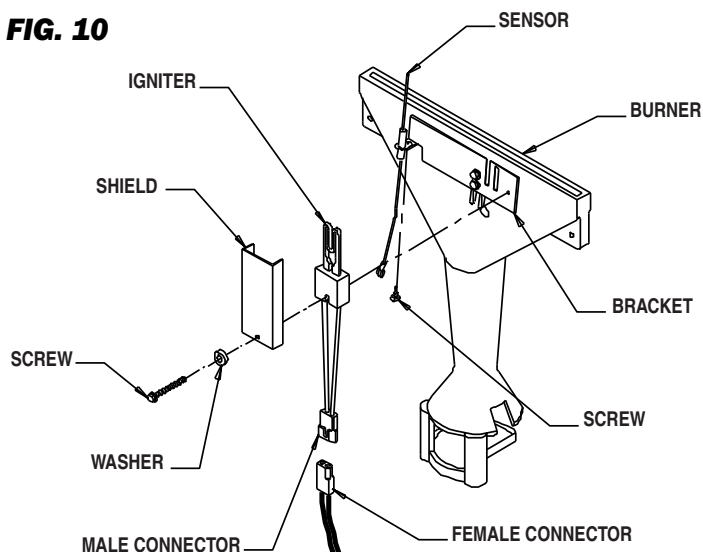

**FIG. 11**

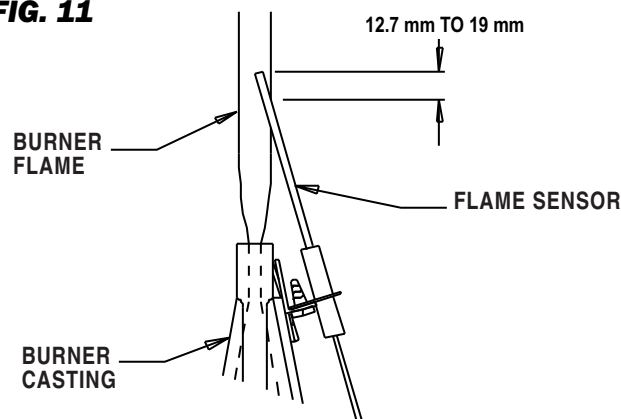

**TESTING THE MANUAL RESET HIGH LIMIT SWITCH**

**WARNING**  
**Fire Hazard**

- Do not operate the appliance with the high limit switch bypassed.
- Operating the heater bypassed high limit switch may lead to overheating, possibly resulting in a fire, with subsequent damage to the heater, building damage, or loss of livestock.

5. Check for electrical continuity across the switch terminals to make sure the contacts have closed.
6. Reinstall the switch back into the heater. Reconnect the heater to its electrical supply. Start the heater and check for proper operation.

The high limit switch should be tested a minimum of once per year when the heater is given a thorough cleaning.

1. Remove the high limit switch from the heat chamber.
2. Holding the switch by one of its mounting legs or electrical terminals, apply a small flame only to the sensing surface on the back of the switch. **Be careful not to melt the plastic housing of the switch when conducting this test.**
3. Within a minute, you should hear a “pop” coming from the switch, which indicates the contacts of the switch have opened.
4. Allow the switch cool down for about a minute before firmly pressing the red reset button on the switch.

**FIG. 12**

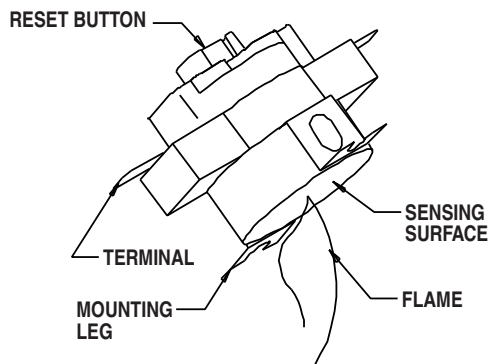

# Gas Pressure Checks

**WARNING**

- Do not disassemble the gas control valve.
- Do not attempt to replace any components of the gas control valve.
- The gas control valve must be replaced if any physical damage occurs to the control valve assembly.
- Failure to follow this warning will result in fire or explosions, leading to injury or death to humans, and property damage.

- The following explains a typical procedure to be followed in checking gas pressures.
- The gas pressures will vary depending upon fuel type.
- Consult the dataplate on the heater or page 4 in this manual for specific pressures to be used in conjunction with this procedure.
- Gas pressure measured at the inlet to the gas valve is Inlet Pressure and gas pressure measured at the outlet of the gas valve is Burner Manifold Pressure.

### A. Preparation

1. Obtain two pressure gauges capable of reading up to 26 kPa.
2. Disconnect the heater from the electrical supply and close the fuel supply valve to the heater inlet.
3. Open the burner access panel.
4. Brush or blow off any dust and dirt on or in the vicinity of the gas control valve.

### B. Gauge Installation

1. Locate the inlet and outlet pressure taps, see Fig. 13. Remove the pressure tap plug using a 3/16 in. allen key.

**FIG. 13**

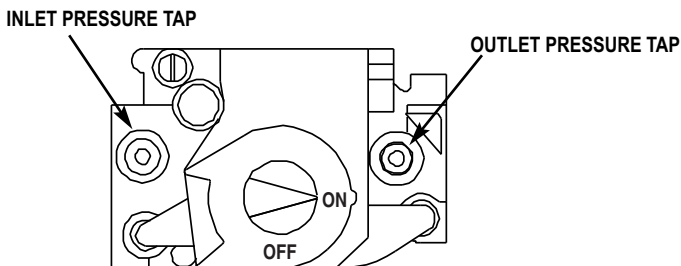

2. Securely connect a pressure gauge to each pressure tap.

3. Open the fuel supply valves to the heater and reconnect the heater electrical supply.
4. Start the heater

### C. Reading Pressures

1. With the heater operating, the pressure gauges should read the pressures specified on the dataplate.
2. Do the readings at the inlet and outlet pressure gauges agree with that specified on the dataplate? If so, then no further checking or adjustment is required. Proceed to section D.
3. If the inlet pressures do not agree with that specified on the dataplate, then the regulator controlling gas pressure to the heater requires adjustment.
4. If the inlet pressures are correct and the burner manifold pressure does not agree with that specified on the dataplate, then the gas control valve's internal pressure regulator requires adjustment. See Fig. 14 for regulator location.

**FIG. 14**

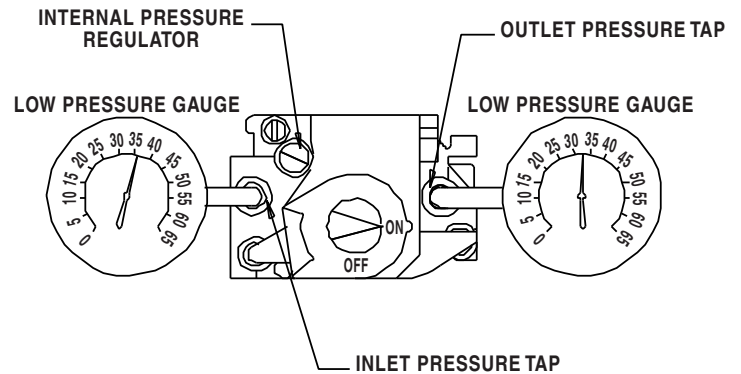

### D. Completion

1. Once the proper inlet and burner manifold pressures have been confirmed and/or properly set, close the fuel supply valve to the heater and allow the heater to burn off any gas remaining in the gas supply line.
2. Disconnect the heater from its electrical supply.
3. Remove the gauges and connecting hoses.
4. Install pressure tap plugs and tighten securely. Check for gas leaks.



# Troubleshooting Guide

## READ THIS ENTIRE SECTION BEFORE BEGINNING TO TROUBLESHOOT PROBLEMS.

 **WARNING**  
**Electrical Shock and Burn Hazard**

- Troubleshooting this system may require operating the unit with line voltage present and gas on. Use extreme caution when working on the heater.
- Failure to follow this warning may result in property damage, personal injury or death.

The troubleshooting flow charts on the following pages provide systematic procedures for isolating equipment problems. The charts are intended for use by a QUALIFIED GAS HEATER SERVICE PERSON. **DO NOT SERVICE THESE HEATERS UNLESS YOU HAVE BEEN PROPERLY TRAINED.**

### TEST EQUIPMENT REQUIRED

The following pieces of test equipment will be required to troubleshoot this system with minimal time and effort.

- **Digital Multimeter** - for measuring AC and DC voltage and resistance.
- **Microamp Diagnostic Kit** - (Part No. 08507) When used with a standard digital multimeter, this kit allows testing of the flame sensor on direct ignition systems.
- **Low Pressure Gauge** - (00764) for checking inlet and outlet pressures of the gas control valve against dataplate rating.

### INITIAL PREPARATION

- Visually inspect equipment for apparent damage.
- Check all wiring for loose connections and worn insulation.

Refer to the system operation sequence in this section to gain an understanding as to how the equipment operates during a call for heat. Understanding the operation sequence of the ignition module and related components is essential as it will relate directly to problem solving provided by the flow charts.

The ignition control module is self-diagnostic. The red light on the module will flash a specific pattern depending upon the problem which is diagnosed. To effectively use the flow charts, you must first identify what the problem is by the flashing pattern of the L.E.D. (light emitting diode) diagnostic light. If the light is flashing, the flash pattern will be followed by a pause and then a repeat of the flash pattern until the problem is corrected. Refer to the tables below to identify what page to refer to when troubleshooting any problems.

<u>Problems</u>	<u>Page</u>
L.E.D. Diagnostic light <u>not</u> on during a call for heat . . .	19
L.E.D. diagnostic light flashing:	
A. Rapid Flash . . . . .	20
B. Long Flash (2 seconds on - 2 seconds off) . . . .	20
C. One Time . . . . .	20
D. Two Times . . . . .	21
E. Three Times . . . . .	22
F. Four Times . . . . .	23
G. Five Times . . . . .	23
H. Six Times . . . . .	23

Components should be replaced only after each step has been completed and replacement is suggested in the flow chart.

**OPERATION SEQUENCE:**

- Line voltage is sent to transformer
  - Terminal at transformer branches off line voltage to terminal L1 on ignition control.
- Transformer reduces line voltage to 24 VAC.
- 24 VAC is sent to thermostat.
- Thermostat closes and returns 24 volts to terminal W on ignition control.
- Red light on ignition control is illuminated.
- Ignition control sends flame sense current to flame sensor.
- Ignition control module performs self safety check.
  - Internal components are tested.
  - Air proving circuit is tested
    - Control sends 24 VAC from terminal PSI to air proving switch.
- Ignition control module begins ignition trial sequence.
- Ignition control sends 220 volts from terminal IND to motor.
  - Motor starts.
- Air proving switch closes and 24 volts are returned to terminal PSO of ignition control.
- Motor stops.
- Ignition control module sends 220 volts to hot surface igniter.
  - Igniter reaches ignition temperature in 15 seconds.
- Ignition control restarts the fan motor while sending 24 VAC to air proving switch.
  - Switch closes and 24 volts are returned back to control.
- Ignition control send 24 volts from terminal GV to high limit switch.
  - If limit switch contacts are closed, limit sends 24 volts to gas control valve
- Gas control valve opens
  - Ignition occurs.
- Flame sense current is passed through burner flame back to ignition control.
- Igniter stays powered until ignition control proves flame sense
  - Igniter then shuts down.
  - Gas control valve stays open
- Room warms to desired temperature.
  - Thermostat is satisfied.
  - Heater shuts down.
- Process starts again on a call for heat.

**IGNITION TRIAL SEQUENCE:**

- First trial for ignition takes approximately 20 seconds
- Two more ignition trials occur
  - Second trial immediately follows if first trial failed.
  - If second trial fails
    - Ignition control starts a 15 minute waiting period
      - Allows the ignition interruption to pass
- At end of 15 minutes
  - Ignition control attempts third and final ignition trial
  - If ignition control does not prove burner flame after third trial, the control goes into safety lockout ( 3 flash)
    - Gas valve closes.
    - Hot surface igniter shuts down
    - Fan motor stops.
- To retry for ignition, turn the heater off and then on.

**LED Constant On → Normal Operation**

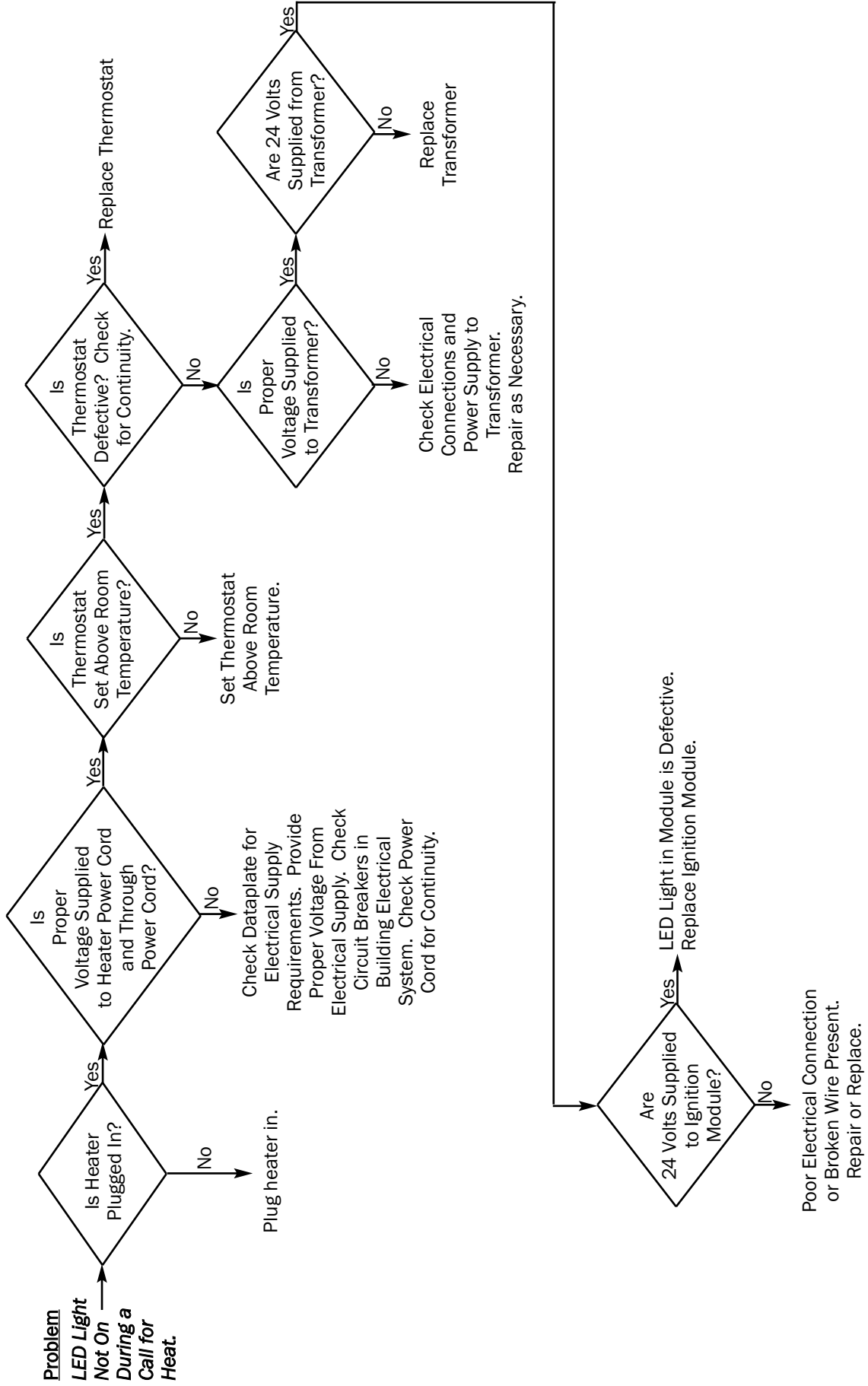

**Problem****LED Flashing**

**Rapid Flash** → Reverse Polarity. Have Electrician Check Neutral and Hot Wire Connections that Outlet Heater is Connected to.

**Long Flash Two Seconds On, Two Seconds Off Repetitively for 15 Minutes.** → Heater has Attempted Two Ignition Trials. Heater is in a 15 Minute Wait Period Before Attempting its Third (Final) Trial for Ignition. If Ignition is not Achieved After the Third Trial, the Heater will Lock Out and the Ignition Control Module will Present the “Three Time” Flash Pattern. Either Recycle the Heater or Wait for Heater to Attempt Third Ignition Trial.

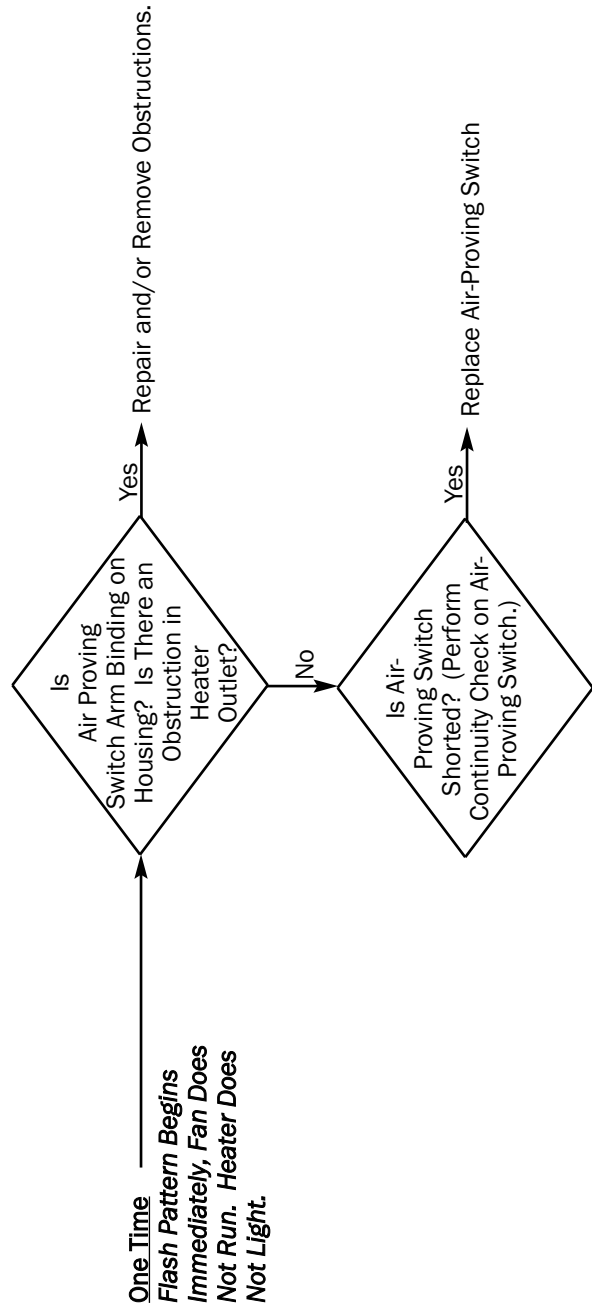

**Two Times Flash Pattern Begins 12 Seconds After Condition Occurs. (Pattern Indicates Lack of "Air Proving" In Fan Section of Unit.)**

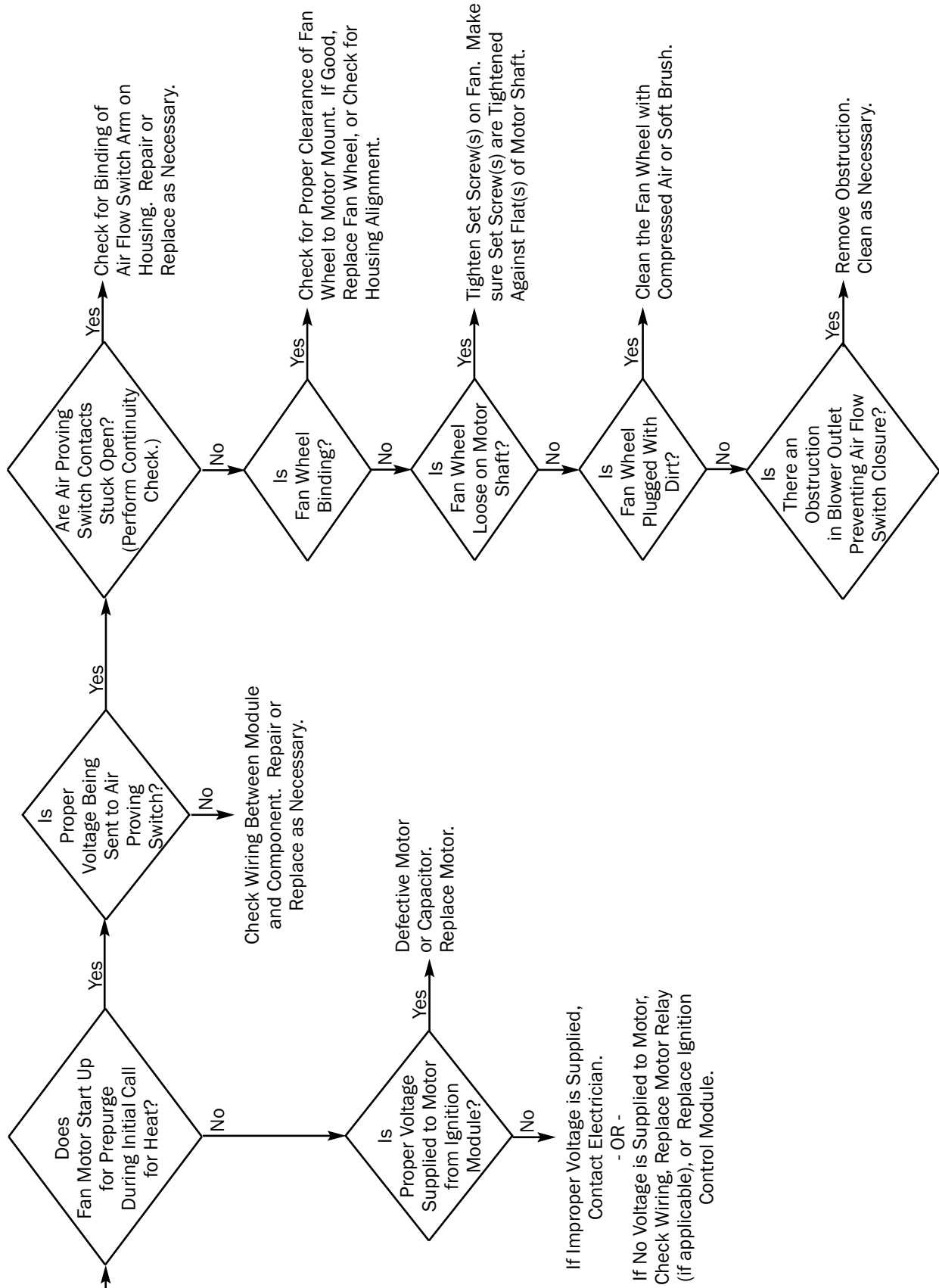

**Three Times Lack of Ignition. Flash Pattern Begins in 15 Minutes After Condition Occurs. The Module Has Gone Into Safety Lockout.**

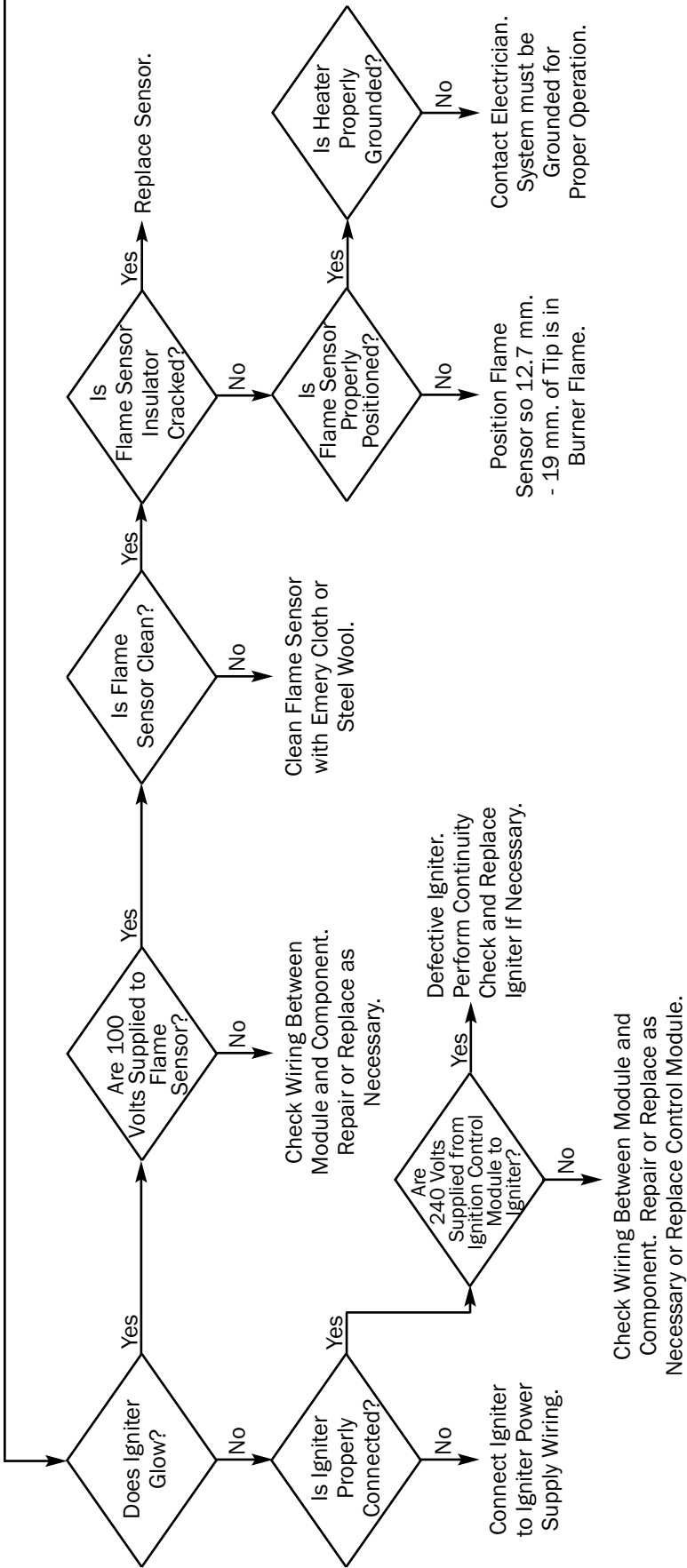
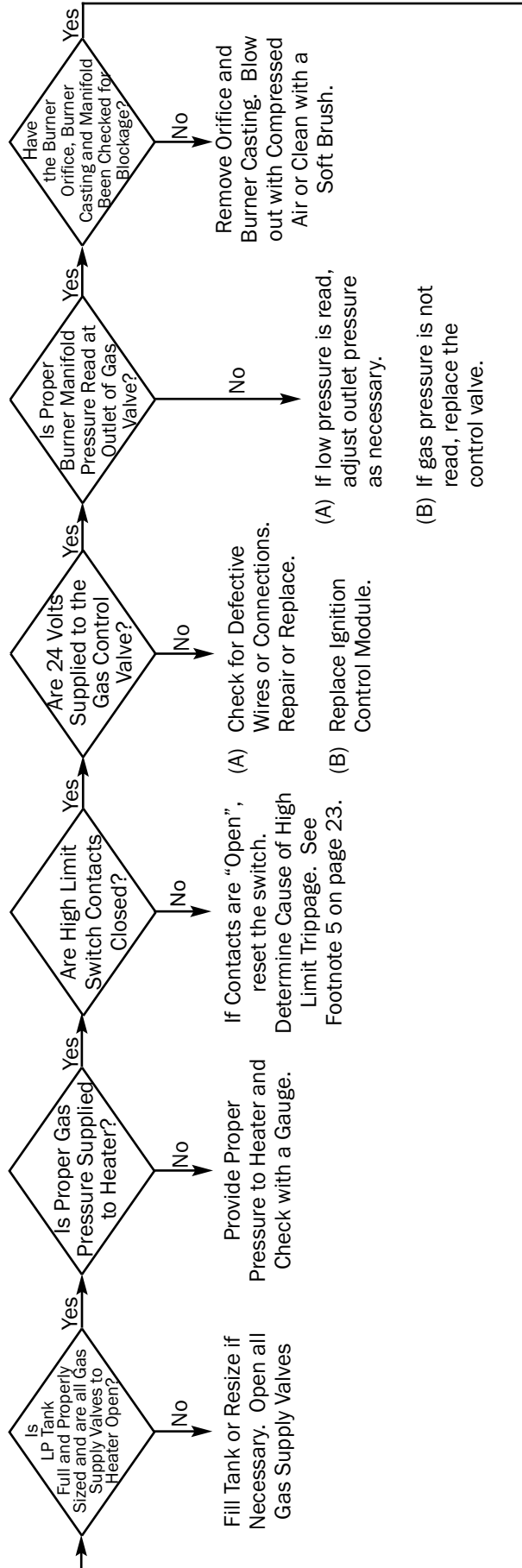

**Four Times** → If HSI board does not reset, then replace the board. (Internal board fault.)  
Have qualified electrician check power source for power quality problems.  
(Frequency, line noise, or line spikes.)

**Five Times** → See Flame Sensor Related Problems  
**Rapid On/Off** in “Three Time” Flash Pattern.  
**Cycling of the Burner.**

**Six Times** → Low Microamp Output For Flame Sensing. Check Microamp  
Output for Proper Flame Proving of Flame Sensor.

- (1) With any electrical problem, all wiring should be checked for good connections and proper voltage and repaired if a problem is found.
- (2) **IMPORTANT:** Remember, the ignition control board sends and receives voltages throughout the entire operation sequence. The HSI board terminals should also be checked for delivering proper voltages, in addition to the individual components as indicated by the respective flash pattern, to make sure the board itself is working properly.
- (3) To determine if part is defective, place a jumper wire across the two terminals that the wires are connected to. Use the jumper wire only to determine if part is defective. Replace the part **IMMEDIATELY** or do not operate unit until properly serviced. **NEVER** operate a heater with a jumper wire used to bypass a safety device as a temporary fix. (NOTE: The sail switch cannot be jumpered prior to ignition taking place as the control system must “prove” the switch contacts close and open during the prepurge cycle.)
- (4) In order to verify the diagnosis of the flashing LED or to reset the unit and retry ignition, disconnect the unit from power and then reconnect to power or if your heater uses a thermostat, turn down thermostat below room temperature and then turn thermostat above room temperature. When testing is completed, reset thermostat to desired temperature.
- (5) The high-limit switch will open or “trip” for a variety of reasons, such as high gas pressure, low voltage, excessive dust and dirt build-up within the heater, dirty fan assembly, fan is not tightened onto motor shaft, and obstructions in air inlets or discharge outlet of heater.
- (6) With a six time flash pattern, the heater will continue to operate as normal. This flash pattern means, however, that flame sense is low and that flame failure or improper operation can occur at any time.

# Electrical Connection and Ladder Diagram

## CAUTION

Always refer to the heater's electrical connection diagram when servicing to avoid wiring errors and heater malfunction. Check for proper operation after servicing.

### WARNING: THIS HEATER MAY START AT ANY TIME

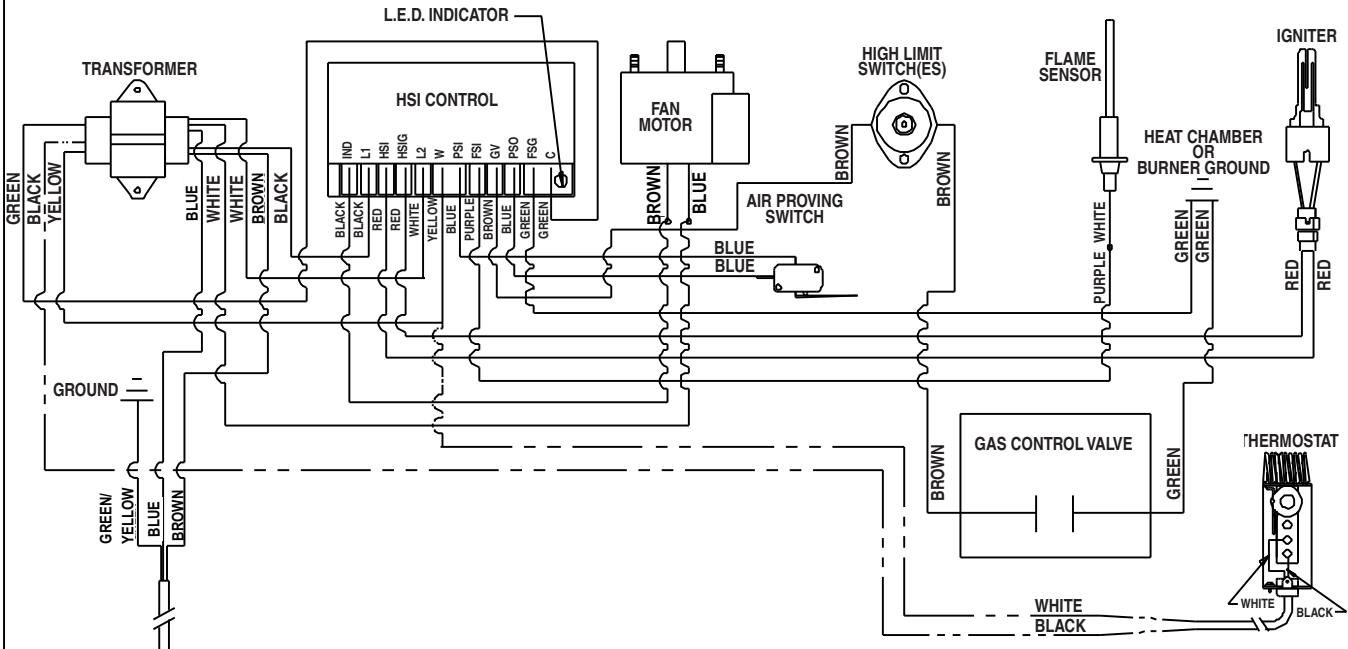

## ELECTRICAL CONNECTION DIAGRAM

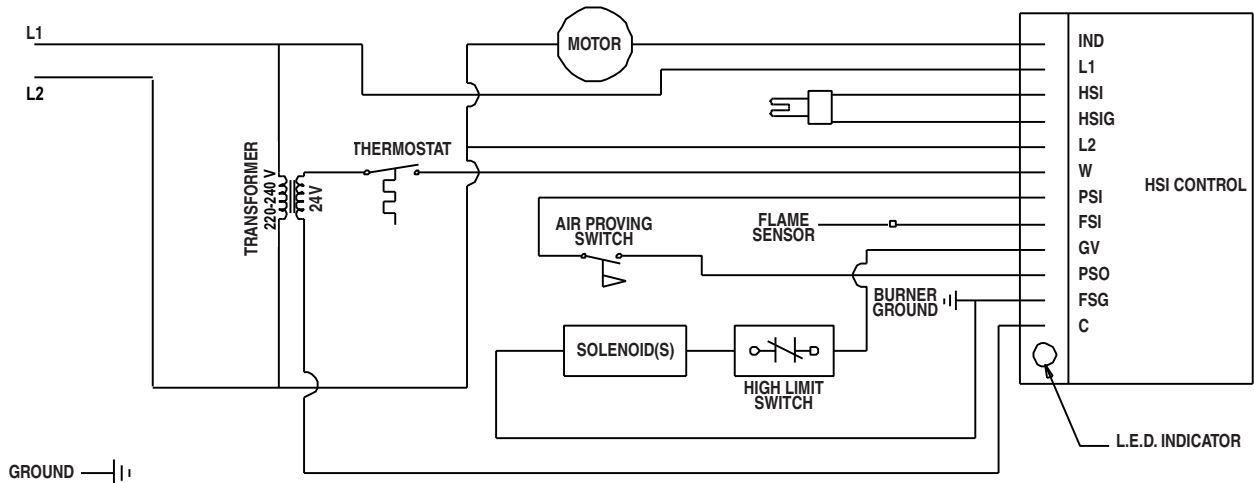

## ELECTRICAL LADDER DIAGRAM

IF ANY OF THE ORIGINAL WIRE AS SUPPLIED WITH THE HEATER MUST BE REPLACED, IT MUST BE REPLACED WITH WIRING HAVING A TEMPERATURE RATING OF AT LEAST 302° F. (150° C.)



---

## **Heater Component Function**

### **Air Proving Switch**

Safety device used to insure that the proper air flow is being achieved before the gas valve is opened.

### **Burner**

Cast iron component used to channel gas and provide an area at which the fuel may ignite.

### **Burner Orifice**

Brass metering device used to feed gas to burner at a specific rate.

### **Fan Housing**

Chamber used for compressing air for efficient air movement.

### **Fan Wheel**

Component used in conjunction with the motor and fan housing to pull the hot air from heater and blow it into room for heating (also known as a squirrel cage).

### **Gas Control Valve**

A device which consists of a low pressure regulator and electrical solenoids which are used for the control of gas flow to the burner assembly. A feature of the control is a built in gas shut off which is used to isolate the heater from its gas supply when servicing.

### **Gas Hose**

Flexible connector used to convey gas from supply line in building to heater.

### **Heat Chamber**

Metal fire box within the appliance that provides an area where burner flame mixes with combustion air thereby providing heat.

### **High Limit Switch**

Safety device wired into the control system which is used to break an electrical circuit to the gas control valve in event of overheat situation.

### **Hot Surface Igniter**

Electrical ignition device used on automatic ignition control systems. Ignites gas by surface temperature rather than by spark or flame.

### **Ignition Control Module**

Controls the ignition sequence and operation of the heater as well as monitoring the safety services. A major service feature is the board's ability to diagnose component and flame failure by means of a diagnostic light located within the module. This light will provide a specific flash pattern repetitively, depending on the type of component failure that has occurred.

### **Motor**

Electric device used to force preheated air through the heater and to circulate heat within a certain area. Converts electrical energy into mechanical energy.

### **Regulator**

The heart of any gas supply installation. Used to deliver a working pressure to the heater under varying conditions in tank pressure.

### **Sensor**

Also known as a flame rod or flame probe, this device works in conjunction with the ignition module in proving that burner flame has been established.

### **Thermostat**

Electrical device used as an automatic on/off switch which will respond to changes in temperature in a certain area. Can be wired so contacts in the thermostat open or close on temperature increase or decrease.

### **Transformer**

Electrical control used to take higher incoming voltage and reduce it to lower outgoing voltage to operate certain control systems.

# Parts Identification

## PARTS SCHEMATIC

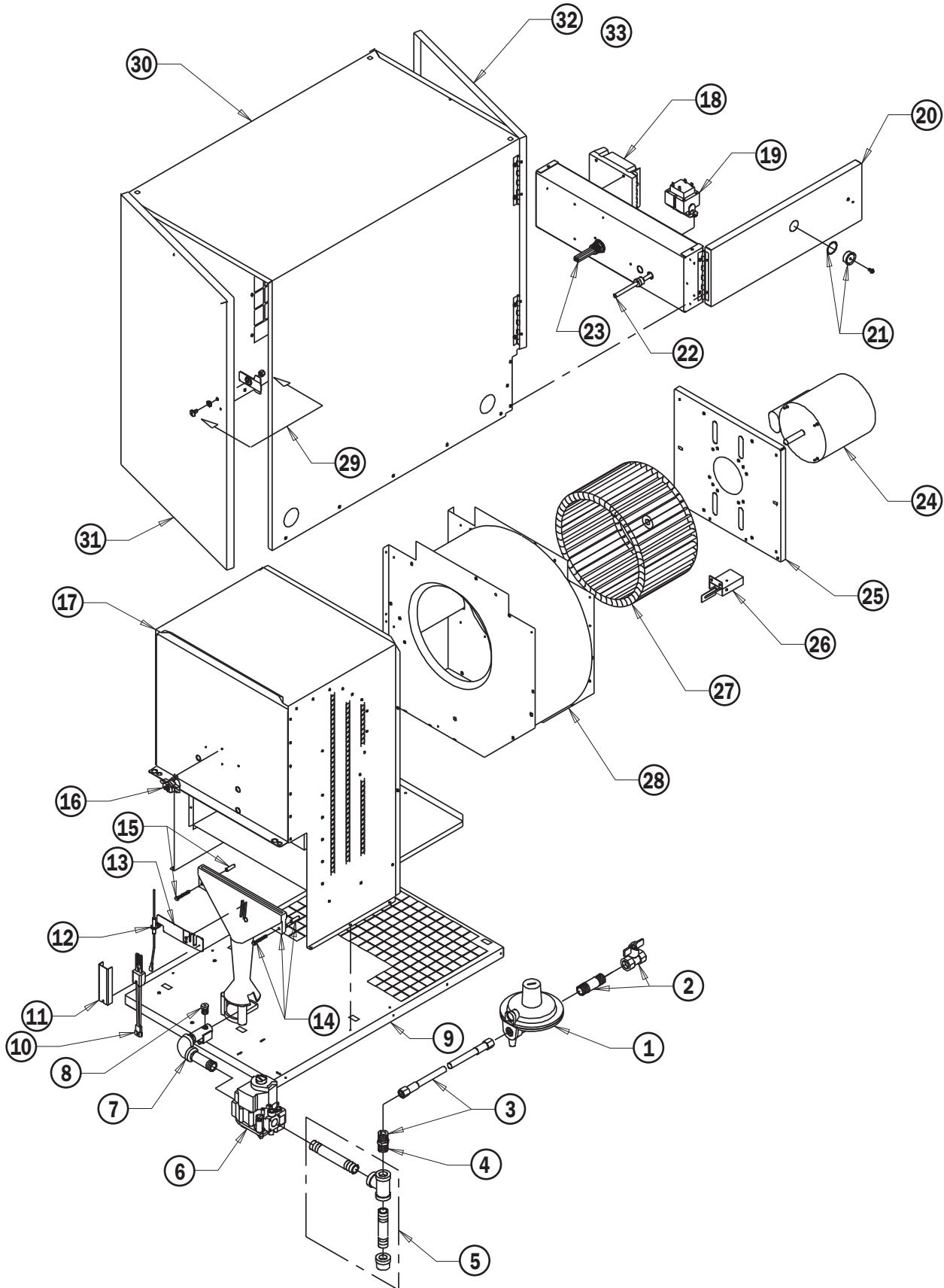

<b>Item</b>	<b>Description</b>	<b>Part Number</b>
1	Regulator, 1/2 NPT, LP Gas, 2nd Stage Vent Over Outlet	06553*
	Regulator, 1/2 NPT, LP Gas, 2nd Stage Vent Over Side	06665*
2	Valve, Ball, Manual Shut Off and 1/2 NPT x 3.5" Nipple	03399*
3	Hose, 1/2" I.D. x 10' w/ 1/2 NPT x 1/2 NPS Hose Adapter	20714*
4	Adapter, Hose 1/2 NPT x 1/2 NPS	25873*
5	Kit, Sediment Trap 1/2 NPT	00815*
6	Valve, Gas Control: LP Gas	573186
7	Manifold	572588
8	Orifice, Burner	570053
9	Base w/ Case Attaching Hardware	570000
10	Igniter	20748
11	Shield, Igniter w/ Hardware	572326
12	Sensor, Flame w/ Hardware	520139
13	Bracket, Igniter w/ Hardware	572327
14	Burner w/ Hardware	570210
15	Burner Mounting Hardware	570211
16	Switch, High Limit	505566
17	Chamber, Heat w/ Hardware	570005
18	Control, Ignition w/ Hardware	509298
19	Transformer w/ Hardware	571900
20	Control Box w/ Cover	572328
21	Window, L.E.D. Viewing/ O-Ring	570002
22	Cord, Power	572329
23	Harness, Wiring	523700
24	Motor w/ Hardware	571902
25	Mount, Motor w/ Hardware	570251
26	Switch, Air Proving w/ Hardware	24157
27	Wheel, Fan w/ Hardware	570481
28	Housing, Fan, w/ Air Proving Switch and Motor Mount	524167
29	Latch, Door	570228
30	Case Assembly w/ Hardware	572330
31	Door, Right w/ Hinges and Latch	570062
32	Door, Left w/ Hinges and Latch	572332

\* Accessory

---

## Warranty Policy

### HEATER

---

L.B. White Co., Inc. warrants that the component parts of its heater are free from defects in material and workmanship, when properly installed, operated, and maintained in accordance with the Installation and Maintenance Instructions, safety guides and labels contained with each unit. If, **within 12 months from the date of purchase by the end user**, any component is found to be defective, L.B. White Co., Inc. will at its option, repair or replace the defective part or heater, with a new part or heater, F.O.B., Onalaska, Wisconsin, USA.

Registering your product online with L.B.White will automatically qualify a unit and its component parts for warranty consideration. If a product has not been registered with L.B.White, a copy of the bill of sale will be required to establish warranty qualification. If neither is available, the warranty period will be 12 months from date of shipment from L B. White.

### PARTS

---

L.B. White Co., Inc. warrants that replacement parts purchased from the company and used on the appropriate L. B. White equipment are free from defects both in material and workmanship for **12 months from the date of purchase by the end user**. Warranty is automatic if a component is found defective within 12 months of the date code marked on the part. If the defect occurs more than 12 months later than the date code but within 12 months from the date of purchase by the end user, a copy of a bill of sale will be required to establish warranty qualification.

The warranty set forth above is the exclusive warranty provided by L.B. White, and all other warranties, including any implied warranties or merchantability or fitness for a particular purpose, are expressly disclaimed. In the event any implied warranty is not hereby effectively disclaimed due to operation of law, such implied warranty is limited in duration to the duration of the applicable warranty stated

above. The remedies set forth above are the sole and exclusive remedies available hereunder. L.B. White will not be liable for any incidental or consequential damages directly or indirectly related to the sale, handling or use of the equipment, and in any event L.B. White's liability in connection with the equipment, including for claims based on negligence or strict liability, is limited to the purchase price.

Some states do not allow limitations on how long an implied warranty lasts, so the above limitation may not apply to you. Some states do not allow the exclusion or limitation of incidental or consequential damages, so the above limitation or exclusion may not apply to you. This warranty gives you specific legal rights, and you may also have other rights which vary from state to state.

To register your product and ensure full warranty, go to

[http://www.lbwhite.com/customer\\_care\\_center/product-registration/](http://www.lbwhite.com/customer_care_center/product-registration/).

Please have the serial number(s) and model(s) handy for the products you are registering.

---

## Replacement Parts and Service

Contact your local L.B. White dealer for replacement parts and service. You may also call the L.B. White Co., Inc. at 001-608-783-5691, for assistance, or email us at [customerservice@lbwhite.com](mailto:customerservice@lbwhite.com). Be sure that you have your heater model number and configuration number when calling.

