

ASSEMBLY and INSTALLATION INSTRUCTIONS



Gas Conversion Kit Oval 80 v.2 Tube Heaters

View these instructions online at www.lbwhite.com

Kit Contents:

DESCRIPTION	QTY.
Instructions	1
Full Gas Train Assembly (Low Pressure Model Only)	1
Conversion Documentation Label	1
Pipe Thread Compound	1
Orifice w/ Bushing (High Pressure Model Only)	1

Tools required:

Pipe Wrench
12 in. Adjustable Wrench
3/8 Open-End Wrench
5/16 Nut Driver
Long Nose Plier

Requirements:

- You must read and understand these instructions before beginning the conversion.
- You must be properly trained and have sufficient experience to install the gas conversion kit and test the heaters for proper operation.
- Ensure the installation's gas type and pressure conform to the gas type and pressure requirements given in the table below.
- Ensure piping is of appropriate size for gas flow capacity.

	Low Pressure Model		High Pressure Model	
	Maximum Inlet Pressure	Minimum Inlet Pressure	Maximum Inlet Pressure	Minimum Inlet Pressure
Propane Vapor Withdrawal	13.5 in. w.c.	11.0 in. w.c.	5 PSIG	5 PSIG
Natural Gas		7.0 in. w.c.		

Discussion:

This conversion kit and instructions pertain to only the "D" design of the Oval 80 tube heaters. If unsure, call the L.B. White Company.

General Instructions:

- Close the main gas supply valve to the heater and disconnect the heater's electrical supply.
- Use pipe thread compound at all threaded connections.
- Ensure all threaded connections are tightened securely.

REMOVAL OF THE OLD GAS TRAIN

- Disconnect the gas hose from the sediment trap
- Disconnect the gas control wires.
- Remove the two nuts securing the gas control bracket to the center partition. See FIG. 1.
- Remove the four bolts securing the gas valve assembly access door. See FIG. 1.
- Pull the gas valve assembly from the heater through the access door.

FIG. 1

LOW PRESSURE GAS VALVE ASSEMBLY SHOWN

GAS VALVE ASSEMBLY ACCESS DOOR

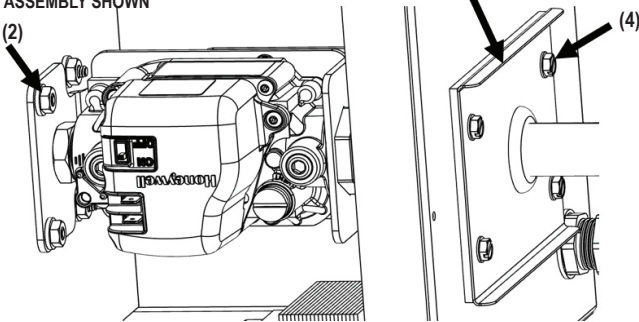

LOW PRESSURE OVAL 80

- Remove the sediment trap nipple and the gas control brackets from the gas valve assembly. See FIG.2.

HIGH PRESSURE OVAL 80

- Remove the reducing bushing along with the orifice from the gas valve assembly. See FIG. 2.

FIG. 2

LOW PRESSURE GAS VALVE ASSEMBLY

SEDIMENT TRAP NIPPLE

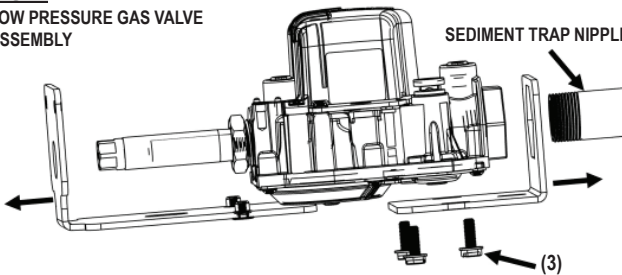

HIGH PRESSURE GAS VALVE ASSEMBLY

BURNER ORIFICE W/ BUSHING

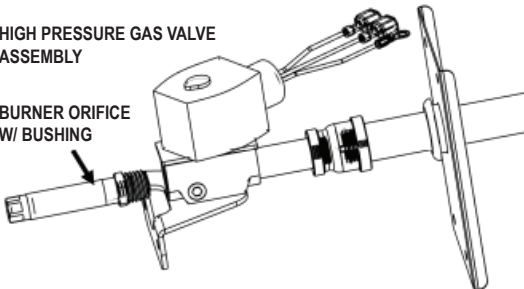

INSTALLING NEW GAS TRAIN

- Reverse the removal process for installing the replacement gas train.

COMPLETION

- Fill out the conversion documentation label and place it below the air intake ring. See FIG. 3.
- Reconnect the gas supply hose to the sediment trap.
- Open all fuel supply valves to the heater.
- Check for gas leaks using approved leak detectors at all gas connections.
- Reconnect the heater to its electrical supply.
- Start the heater and check for proper heater operation.

FIG. 3

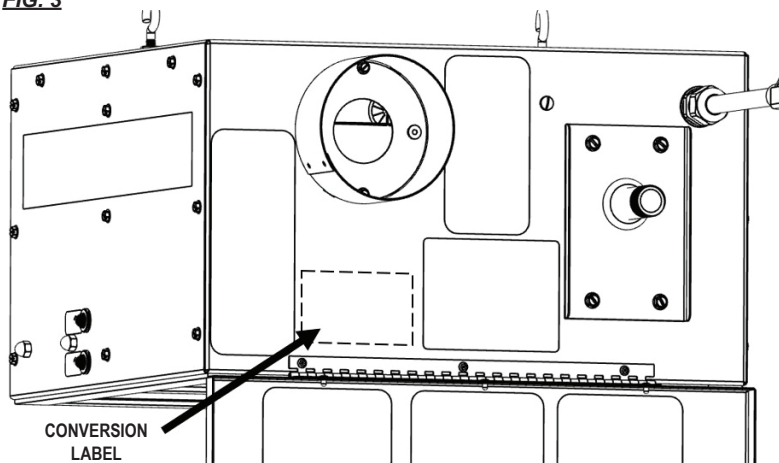

Service

Contact your local L.B. White dealer for replacement parts and service. You may also call the L.B. White Company, LLC at 1-800-345-7200, for assistance, or email us at customerservice@lbwhite.com.

Be sure that you have your heater model number and configuration number when calling.



**WORLD PROVIDER - INNOVATIVE
HEATING SOLUTIONS**

411 Mason Street, Onalaska, WI 54650

800-345-7200 • 608-783-5691

608-783-6115 (fax)

www.lbwhite.com