

ASSEMBLY and INSTALLATION INSTRUCTIONS



Gas Conversion Kit Forced Air Heaters

View these instructions online at www.lbwhite.com

Kit Contents:

DESCRIPTION	QTY.
Instructions	1
Full Gas Train Assembly	1
Conversion Documentation Label	1
Pipe Thread Compound	1

Tools required:

Pipe Wrench
Ratchet
7/16 Socket
Phillip Screwdriver
Long Nose Plier

Requirements:

- You must read and understand these instructions before beginning the conversion.
- You must be properly trained and have sufficient experience to install the gas conversion kit and test the heaters for proper operation.
- Ensure the installation's gas type and pressure conform to the gas type and pressure requirements given in the table below.
- Ensure the gas supply piping is of appropriate size to support the heaters gas flow capacity.

	Maximum Inlet Pressure	Minimum Inlet Pressure
Propane Vapor Withdrawal	13.5 in. w.c.	11.0 in. w.c.
Natural Gas		7.0 in. w.c.

Discussion:

The following instructions are for a full gas train assembly conversion kit. If unsure, call the L.B. White Company.

General Instructions:

- Close the main gas supply valve to the heater and disconnect the heater's electrical supply.
- Use pipe thread compound at all threaded connections.
- Ensure all threaded connections are tightened securely.

REMOVAL OF THE OLD GAS TRAIN

- Disconnect the gas hose from the sediment trap and remove the sediment trap from the inlet of the gas control valve.
- Disconnect the gas control valve's wiring.
- Remove the black plastic bushing on the side of the case. See FIG.1.
- Remove the two screws securing the gas valve to the bracket as shown in FIG. 1. AW250 heater shown.

FIG. 1

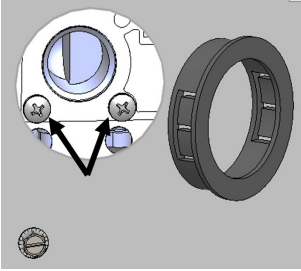

- Remove the burner retaining bolt and washer from under the heater's base as shown in FIG.2. AW250 heater shown.

FIG. 2

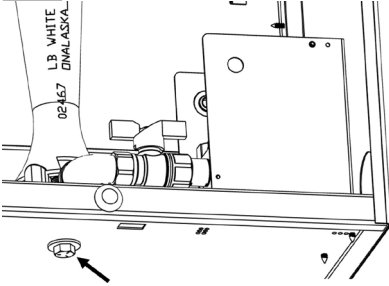

- Lift and pivot the gas control assembly as needed to remove it from the heater, AW250 heater shown. See FIG.3.

FIG. 3

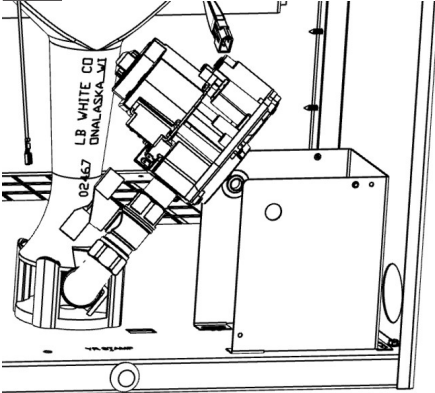

INSTALLING NEW GAS TRAIN

- Reverse the removal process for installing the replacement gas train.

COMPLETION

- Reconnect the sediment trap to the heater. Use the provided pipe thread compound.
- Connect the gas supply hose to the sediment trap.
- Ensure the variable rate valve, if applicable, is in the **full throttle** position.
- Fill out the conversion documentation label.
- For Guardian and Premier heater, place the label on the door near the dataplate. See FIG. 4 & FIG. 5.
- For ThermaGrow heater, place the label above the dataplate on the back panel.

FIG. 4

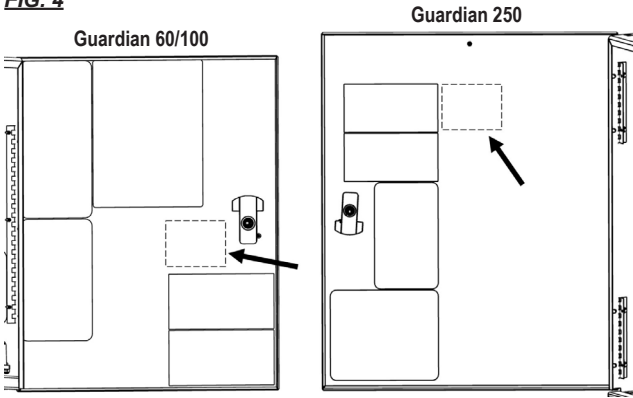
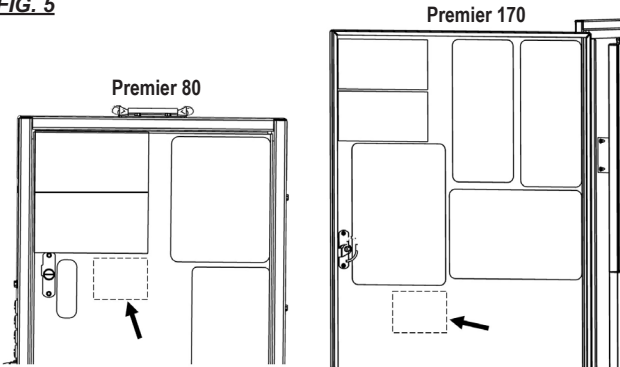

FIG. 5



- Open all fuel supply valves to the heater.
- Check for gas leaks using approved leak detectors at all gas connections.
- Reconnect the heater to its electrical supply and start the heater.
- Check for proper heater operation. Ensure the supply pressure to the heater is set according to specifications in the owner's manual or refer to the table on the cover page.

Service

Contact your local L.B. White dealer for replacement parts and service. You may also call the L.B. White Company, LLC at 1-800-345-7200, for assistance, or email us at customerservice@lbwhite.com.

Be sure that you have your heater model number and configuration number when calling.



**WORLD PROVIDER - INNOVATIVE
HEATING SOLUTIONS**

411 Mason Street, Onalaska, WI 54650

800-345-7200 • 608-783-5691

608-783-6115 (fax)

www.lbwhite.com